



Image shown may not reflect actual Engine

SPECIFICATIONS

I-6, 4-Stroke-Cycle-Diesel

Emissions.....	IMO
Displacement.....	18.1 L (1106 cu in)
Rated Engine Speed.....	2300
Bore.....	145.0 mm (5.7 in)
Stroke.....	183.0 mm (7.2 in)
Aspiration.....	Turbocharged-Aftercooled
Governor.....	Electronic
Cooling System.....	Heat Exchanger
Weight, Net Dry (approx.).....	1,718 kg (3,788 lb)
Refill Capacity	
Cooling System.....	45 L (12 Gal)
Lube Oil System.....	49 L (13 Gal)
Caterpillar Diesel Engine Oil	10W30 or 15W40
Rotation (from flywheel end).....	Counterclockwise
Flywheel and Flywheel Housing.....	SAE No. 1
Flywheel Teeth	
Maximum Exhaust Backpressure.	10.0 kPa (40.2 in. water)

STANDARD ENGINE EQUIPMENT

Air Inlet System

Corrosion resistant aftercooler core, light duty air cleaner (open system)

Cooling System

Self priming auxiliary sea water pump with rubber impeller, gear driven jacket water pump, titanium plate heat exchanger with expansion tank, coolant recovery system, thermostat and housing

Exhaust System

Watercooled exhaust manifold and turbocharger, round flanged outlet

Fuel System

Fuel priming pump, fuel transfer pump, fuel filter - RH or LH service, flexible fuel lines

Instrumentation

24V instrument panel with electric service meter, start/stop switch, emergency stop button, maintenance due lamp, diagnostic lamp, warning lamp, maintenance clear switch, 15A and 3A breakers, and starter motor magnetic switch

Lube System

Crankcase breather, engine oil cooler, oil filter - RH or LH service, oil level gauge - RH or LH service, oil filler, shallow oil pan, gear driven oil pump

Mounting System

Front support - adjustable

Power Takeoffs

11 tooth spline SAE A hydraulic pump drive, two groove crankshaft pulley

Protection System

12 or 24V electronic shutdown (energize-to-run)

General

Vibration damper and guard, Caterpillar yellow paint, lifting eyes, customer wiring connector and service tool connector

ISO Certification

Factory-designed systems built at Caterpillar
ISO 9001:2000 certified facilities

PERFORMANCE CURVES

E-RATING - DM6446-03

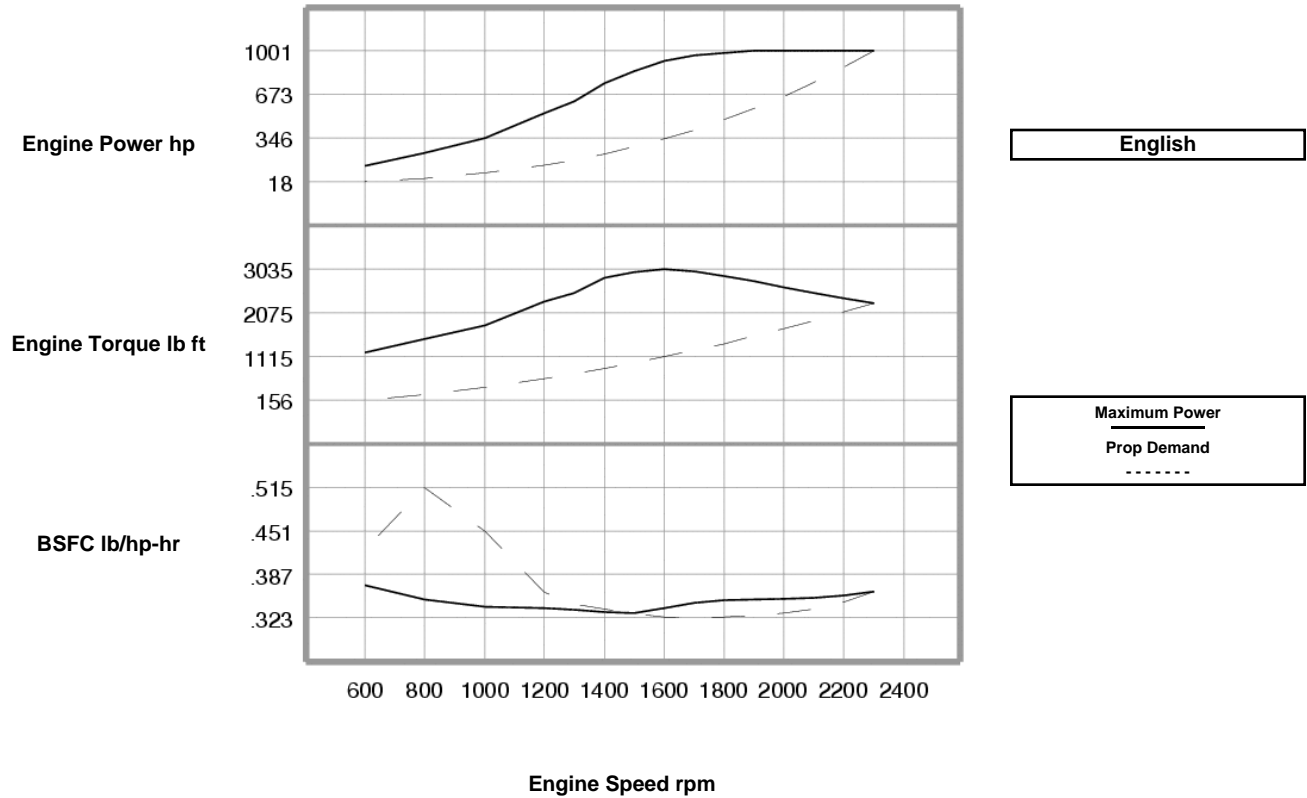

Maximum Power Data					Prop Demand Data				
Engine Speed rpm	Engine Power hp	Engine Torque lb ft	BSFC lb/hp-hr	Fuel Rate gph	Engine Speed rpm	Engine Power hp	Engine Torque lb ft	BSFC lb/hp-hr	Fuel Rate gph
2300	1001	2286	.362	51.7	2300	1001	2286	.362	51.7
2200	1001	2390	.356	50.9	2200	876	2092	.346	43.3
2100	1001	2504	.352	50.4	2100	762	1906	.336	36.6
2000	1001	2629	.350	50.1	2000	658	1729	.330	31.0
1900	1001	2767	.349	50.0	1900	564	1560	.326	26.3
1800	985	2874	.348	49.0	1800	480	1400	.324	22.2
1700	964	2978	.345	47.4	1700	404	1249	.323	18.7
1600	925	3035	.337	44.5	1600	337	1106	.325	15.6
1500	846	2964	.330	39.9	1500	278	972	.329	13.1
1400	755	2834	.331	35.7	1400	226	847	.336	10.8
1300	620	2507	.335	29.7	1300	181	730	.343	8.8
1200	529	2314	.336	25.4	1200	142	623	.360	7.3
1000	342	1797	.339	16.6	1000	82	432	.451	5.3
800	229	1502	.350	11.4	800	42	277	.515	3.1
600	136	1194	.371	7.2	600	18	156	.424	1.1

NOTE: Prop demand data is a cubic prop demand curve with 3.0 exponent for displacement hulls only.

DIMENSIONS

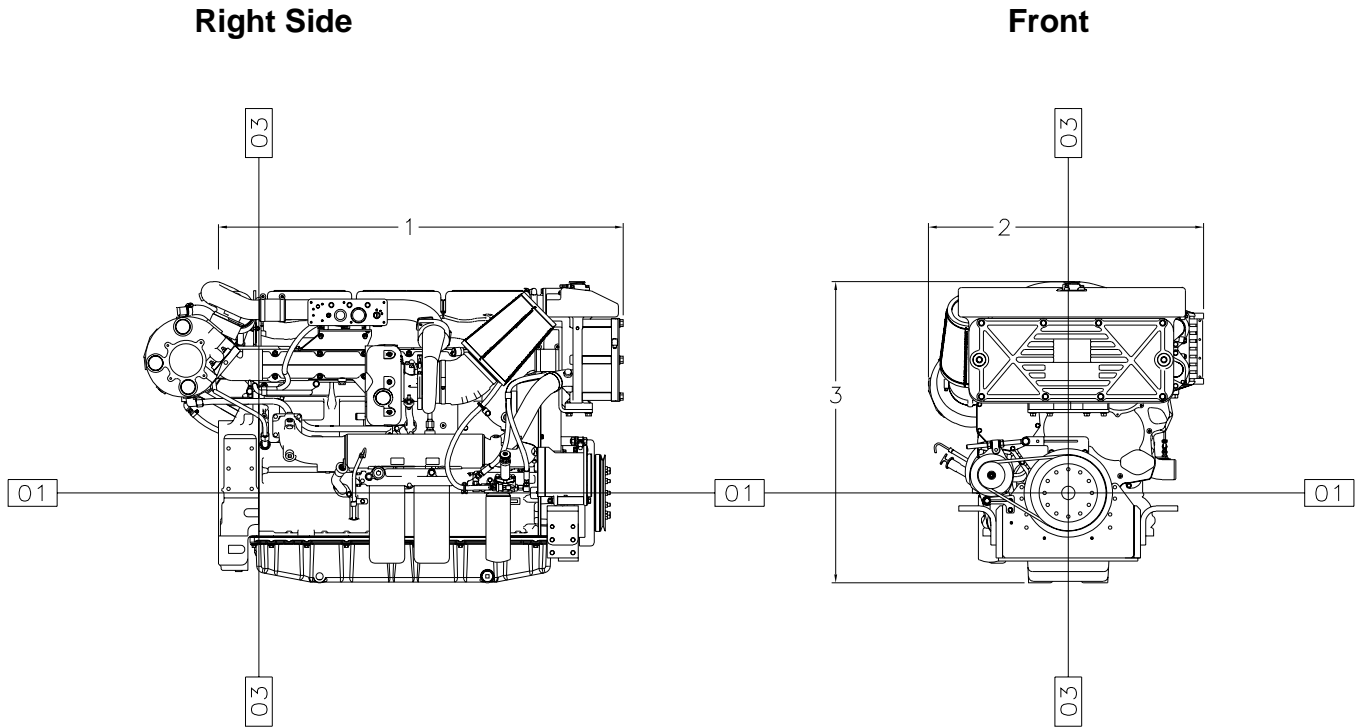

Engine Dimensions		
(1) Length to Flywheel Housing	1558.0 mm	61.34 in
(2) Width	1057.9 mm	41.65 in
(3) Height	1172.4 mm	46.16 in
Weight, Net Dry (approx)	1718 kg	3,788 lb

Note: Do not use for installation design. See general dimension drawings for detail (Drawing # 2070024).

RATING DEFINITIONS AND CONDITIONS

E Rating (High Performance) -

% Load Factor: up to 30

% Time at Rated RPM: up to 8

Typical Time at Full Load: 1/2 hours out of 6

Typical Hour/Year: 250 to 1000

Typical Applications: For vessels operating at rated load and rated speed up to 8% of the time (up to 30% load factor). Typical applications could include but are not limited to vessels such as pleasure craft, harbor patrol boats, harbor master boats, some fishing or patrol boats. Typical operation ranges from 250 to 1000 hours per year.

Power

at declared engine speed is in accordance with ISO3046-1:2002E. Caterpillar maintains ISO9001:1994/QS-9000 approved engine test facilities to assure calibration of test equipment. Electronically controlled engines are set at the factory at the advertised power corrected to standard ambient conditions. The published fuel consumption rates are in accordance with ISO3046-1.

Fuel rates

are based on fuel oil of 35° API [16°C (60°F)] gravity having an LHV of 42 780 kJ/kg (18,390 Btu/lb) when used at 29°C (85°F) and weighing 838.9 g/L (7.001 lb/U.S. gal). Additional ratings may be available for specific customer requirements. Consult your Caterpillar representative for additional information.

Performance data is calculated in accordance with tolerances and conditions stated in this specification sheet and is only intended for purposes of comparison with other manufacturer's engines. Actual engine performance may vary according to the particular application of the engine and operating conditions beyond Caterpillar's control.

Power produced at the flywheel will be within standard tolerances up to 49° C (120° F) combustion air temperature measured at the air cleaner inlet, and fuel temperature up to 52° C (125°F) measured at the fuel filter base. Power rated in accordance with NMMA procedure as crankshaft power. Reduce crankshaft power by 3% for propeller shaft power.

Performance No.: DM6446-03

Feature Code: C18MC01

U.S. Sourced

12089785

28 March 2008

©2008 Caterpillar

All rights reserved.

Materials and specifications are subject to change without notice.

The International System of Units (SI) is used in this publication.

CAT, CATERPILLAR, SAFETY.CAT.COM their respective logos, "Caterpillar Yellow," and the POWER EDGE trade dress, as well as corporate and product identity used herein, are trademarks of Caterpillar and may not be used without permission.