

# 4000 Series

Spark Ignited Gas Engine

# 4016TESI

800 kWm at 1200 rpm  
842 kWm at 1500 rpm

Designed in advance of today's uncompromising demands within the gas power generation industry, the Perkins 4000 Series family of 6, 8, 12 and 16 cylinder spark ignition gas engines offers superior performance, dependability and reliability.

The 4016TESI is a turbocharged and air-to-water charged cooled 16 cylinder vee-form engine designed for operation on a wide range of gases including natural, landfill and digester gases. The internationally proven durability and reliability, combined with exceptional thermal efficiency and reduced whole life costs, make selection of the Perkins 4000 Series engine as prime mover the obvious choice. The 4000 Series spark ignited gas engine can be supplied to suit customer requirements as a Gas Electro Unit for power generation or Cogen Unit specification for combined heat and power operation.

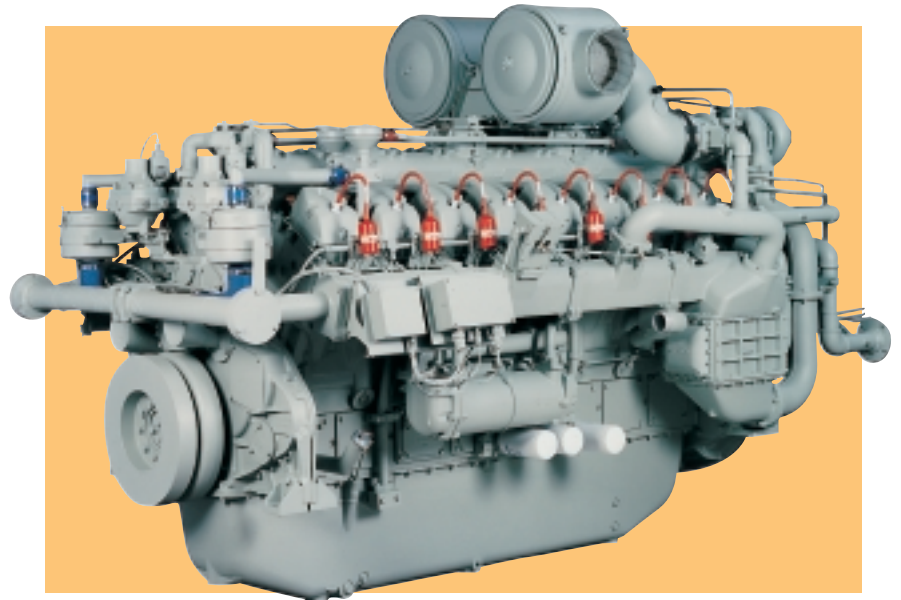

## Economic power

- The modern design of the 4000 Series incorporates the latest development and engineering techniques, resulting in excellent durability, economical whole life costs and reliability.

## Efficient power

- Designed for maximum thermal efficiency, the 4016TESI offers compact, high power to weight ratio, an economical solution to power and heat requirements.
- High commonality of components with other engines in the 4000 Series family offers reduced stocking and inventory levels.

## Reliable power

- The high level of product serviceability and ease of maintenance maintain optimum availability.
- Total after-sales service, backed by Perkins' world-wide distributor/dealer network.

| Engine Speed rev/min | Type of Operation          | Gross Engine Power |     |
|----------------------|----------------------------|--------------------|-----|
|                      |                            | kWe                | kWm |
| 1200                 | Continuous Operation Power | 772                | 800 |
| 1500                 | Continuous Operation Power | 815                | 842 |

The above ratings represent the engine performance capabilities in accordance with ISO 3046 at reference conditions equivalent to those specified in ISO 3046/1. Electrical ratings are based on average alternator efficiency at a unity power factor based on natural gas having a lower calorific value of 34.71 MJ/m<sup>3</sup>.

Please consult your local Perkins distributor/dealer or Perkins Engines Company Limited for derating calculations for ambient conditions or use of gaseous fuels other than British natural gas.

**Continuous Operation Power** – A 'true' Baseload rating as defined in ISO 8528 as COP.

## Standard Gas Engine Specification

### Core engine

- High-grade cast iron cylinder block featuring integral crankcase inspection doors
- Wet liners in centrifugally cast iron, plateau honed for quick ring bedding and excellent oil control
- Forged steel crankshaft
- Forged camshaft – carburised hardened
- High grade cast iron individual cylinder heads, each with four valves per cylinder
- Crankshaft driven gear train for camshaft
- Aluminium alloy gallery (oil) cooled piston with three-ring pack
- Split cap connecting rods, forged steel with 2 bolt fixing – shot peened

### Gas/ignition system

- Air/fuel mixers with zero pressure regulator and mixture adjustment screws
- Metal braided flexible gas connection
- Altronic 800 °C Series ignition system and wiring harness
- Individual cylinder ignition coils with leads

### Lubrication system

- Gear driven lubricating oil pump, externally mounted
- Spin on type replaceable lubricating oil filters
- Shell and tube type oil coolers, jacket water cooled
- Crankcase closed circuit ventilation

### Cooling system

- Pressurised fresh water jacket water cooling system
- Centrifugal type, gear driven pumps and thermostatic control †
- Air to water charge coolers, secondary water cooled
- Secondary water pump, centrifugal type, gear driven †
- Charge cooler water thermostat, loose supply †

### Air intake system

- Paper element air filters with restriction indicators
- Twin exhaust gas driven turbochargers

### Exhaust system

- Cast iron, jacket water cooled exhaust manifolds
- Twin vertical exhaust outlets †

### Governing system

- Electronic governing system, conforming to ISO 8528 Part 5 Class G2

### Electrical system

- 24 Volt electric starter motors
- 24 Volt battery charging alternator †

### Drive system

- Cast iron flywheel housing SAE 00 and flywheel SAE J620 Size18
- Viscous type torsional vibration damper(s)

### Engine protection system

- 24 Volt high coolant temperature and low oil pressure switches
- Overspeed switch and probe
- Emergency stop button – grounding ignition system
- High manifold pressure switch

### Engine mountings

- Engine supports: front and rear feet mounted off the crankcase

### Painting

- Commercial primer finish

### Packing/Preservation

- All engines are preserved after test running, shrink wrapped and suitable for containerised shipment

† Not supplied on Cogen Unit

## Technical Data

|                                       |  |
|---------------------------------------|--|
| <b>Number of cylinders</b>            | 16   |
| <b>Cylinder arrangement</b>           | 60° Vee  |
| <b>Cycle</b>                          | 4-stroke   |
| <b>Induction system</b>               | Turbocharged, charge cooled                                |
| <b>Combustion system</b>              | Spark ignition   |
| <b>Cooling system</b>                 | Water cooled   |
| <b>Displacement</b>                   | 61.12 litres   |
| <b>Bore and stroke</b>                | 160 mm x 190 mm  |
| <b>Compression ratio</b>              | 9.5:1 low compression (LC)<br>11.5:1 high compression (HC) |
| <b>Direction of rotation</b>          | Anti-clockwise, viewed on flywheel                         |
| <b>Total lubrication oil capacity</b> | 177.6 litres   |
| <b>Coolant capacity</b>               | 73 litres  |
| <b>Engine dimensions:</b>             |  |
| <b>Total weight (dry)</b>             | 5820 kg  |
| <b>Length</b>                         | 3195 mm  |
| <b>Width</b>                          | 1895 mm  |
| <b>Height</b>                         | 2118 mm  |

| Fuel consumption kJ/kWs |              |              |
|-------------------------|--------------|--------------|
|                         | 1500 rev/min | 1800 rev/min |
| <b>4016TESI 200LC</b>   |              |              |
| 100% of COP rating      |              | 2.91         |
| 75% of COP rating       |              | 3.04         |
| <b>4016TESI 140LC*</b>  |              |              |
| 100% of COP rating      | 2.81         | 2.98         |
| 75% of COP rating       | 2.86         | 3.13         |
| <b>4016TESI 140HC*</b>  |              |              |
| 100% of COP rating      |              | 2.74         |
| 75% of COP rating       |              | 2.84         |
| <b>4016TESI 90HC#</b>   |              |              |
| 100% of COP rating      | 2.75         | 2.78         |
| 75% of COP rating       | 2.80         | 2.88         |

\*Complies with TA Luft emissions regulations as regards NOx, CO and HC

#1/2TA Luft: An oxidising catalyst may be required

COP: Continuous Operation Power

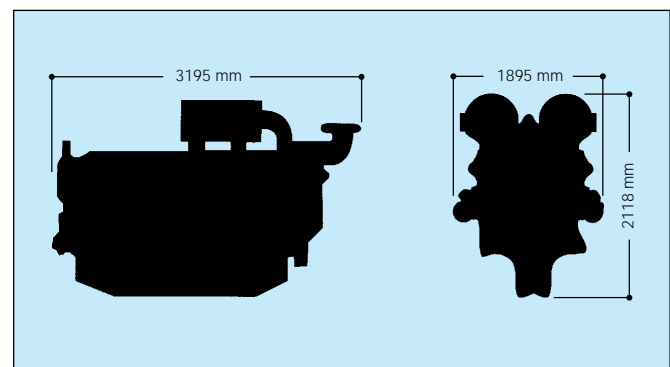

**Perkins Engines Company Limited**

Tixall Road Stafford ST16 3UB United Kingdom  
 Telephone 01785 223141  
 Fax 01785 215110  
 www.perkins-engines.com

All information given in this leaflet is correct at the time of printing but may be changed subsequently by the company.

Distributed by