

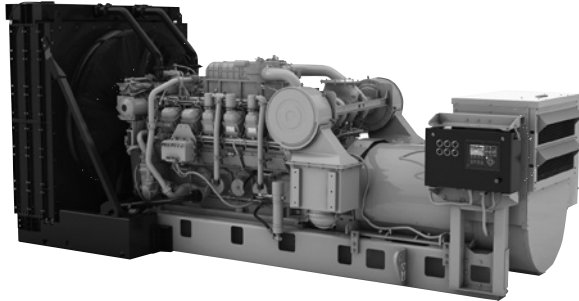

3512C HD Land Electric-Drive Drilling Module

1305 kW
(1750 bhp)
1200 rpm



CAT® MODULE SPECIFICATIONS

V-12, 4-Stroke-Cycle-Diesel

Emissions	EPA/CARB Tier 2 Non-Road Emissions Certified
Bore	170 mm (6.7 in)
Stroke	215 mm (8.5 in)
Displacement	59 L (3574 cu. in)
Aspiration	Turbocharged-Aftercooled Governor and Protection
Electronic ADEM™ A3	
Engine Weight, net dry (approx)	7099 kg (15,650 lb)
Module Weight, net dry (approx)*	16,946 kg (37,360 lbs)
Capacity for Liquids	
Lube Oil System (refill)	318 L (84 U.S. gal)
Engine Cooling System	157 L (41.5 U.S. gal)
Oil Change Interval	500 hours

*Module weight includes base, radiator, generator, and engine

FEATURES

Engine Design

- Proven reliability and durability
- Robust diesel strength design prolongs life and lowers owning and operating costs
- Assembled, tested, and validated as a package to minimize package vibration and maximize component life
- Market-leading power density
- Designed to perform in oilfield conditions, including high ambient high altitude applications
- Long overhaul life proven in oilfield applications
- Core engine components designed for reconditioning and reuse at overhaul

Advanced Digital Engine Management

ADEM A3 engine management system integrates speed control, air/fuel ratio control, and ignition/detonation controls into a complete engine management system. ADEM A3 has improved user interface, display system, shutdown controls, and system diagnostics and allows electronic integration with transmissions.

Safety

- E-Stop pushbutton on instrument panel
- Air shutoff and explosion relief valves
- Configurable alarm and shutdown features
- Extra alarm switches available for customer-supplied panel

Ease of Installation and Packaging

- Installed radiator
- Customer interface harness
- Simple engine/package wiring
- Adapters, fittings, and connectors available for cooling, air and exhaust system

Improved Serviceability

Large inspection openings allow convenient access to core engine internals

Reduction of Owning and Operating Costs

- Long filter change intervals, aligned with service intervals
- Excellent fuel economy — direct injection electronic unit injectors precisely meter fuel

Custom Packaging

For any petroleum application, trust Caterpillar to meet your exact needs with a factory custom package. Cat engines, generators, enclosures, controls, radiators, transmissions — anything your project requires — can be custom designed and matched to create a one-of-a-kind solution. Custom packages are globally supported and are covered by a one-year warranty after startup.

Full Range of Attachments

Large variety of factory-installed engine attachments reduces packaging time

Testing

Every Cat module is full-load tested to ensure proper engine performance.

Product Support Offered Through Global Cat Dealer Network

More than 2,200 dealer outlets

Cat factory-trained dealer technicians service every aspect of your petroleum engine

Cat parts and labor warranty

Preventive maintenance agreements available for repair-before-failure options

S•O•SSM program matches your oil and coolant samples against Caterpillar set standards to determine:

- Internal engine component condition
- Presence of unwanted fluids
- Presence of combustion by-products
- Site-specific oil change interval

Over 80 Years of Engine Manufacturing Experience

Ownership of these manufacturing processes enables Caterpillar to produce high quality, dependable products.

- Cast engine blocks, heads, cylinder liners, and flywheel housings
- Machine critical components
- Assemble complete engine

Web Site

For all your petroleum power requirements, visit www.catoilandgasinfo.com.



STANDARD EQUIPMENT

Air Inlet System

Aftercooler core — corrosion resistant coating
Air cleaners — heavy duty, installed
Air inlet shutoff

Base Arrangement

Oilfield base
Oil drain extension

Control System

ADEM A3 electronic control module with electronically controlled unit injectors (24 volt DC power from SCR control system)
Requires 24 volt DC 10 amp continuous, 20 amp intermittent, clean electrical power; uses J1939 communications

Cooling System

To ensure emissions compliance, optional or customer supplied radiators must be capable of rejecting enough heat to allow proper operation at worst case site conditions and also must supply 50° C (122° F) SCAC cooling water to the aftercooler inlet, with an SCAC flow rate of at least 130 gpm with an ambient temperature of 30° C (86° F) and at site conditions.

Radiator Cooled Land Based:

Outlet controlled thermostat and housing
Jacket water pump — gear-driven
Dual outlet
Aftercooler fresh water cooling pump — gear-driven centrifugal
SCAC pump circuit contains a thermostat to keep the aftercooler coolant from falling below 50° C (122° F)

Exhaust System

Exhaust fittings — flexible
Exhaust flange — weldable
Exhaust manifolds — dry

Flywheels and Flywheel Housings

Flywheel — SAE No. 00, 183 teeth
Flywheel housing — SAE No. 00, SAE standard rotation
Coupling and generator hub

Fuel System

Electronically controlled unit injectors
Fuel filter — LH
Fuel transfer and priming pumps, flexible fuel lines

Generator

SR4B, two-bearing, 600 V, 60 Hz, 3-phase, 0.7 pf, 6 wire, wye connected, brushless (voltage regulator is optional), space heater and 10 ohm platinum temperature detectors

Instrumentation

Electronic instrument panel — LH
Analog gauges for: oil and fuel pressure, oil and fuel filter differential, system DC voltage, exhaust and water temperature, fuel pressure, air inlet restriction
Digital display for: tachometer, service meter, hours, fuel consumption — total and instantaneous

Lube System

Crankcase breather — top mounted
Shallow sump oil pan
Oil filler and dipstick — LH
Oil filter — cartridge-type, LH
Oil pump — gear-type

Protection System

ADEM A3 monitoring system provides engine deration, alarm, or shutdown strategies to protect against adverse operating conditions. Selected parameters are customer programmable. Status available on engine-mounted instrument panel and can be broadcast through the optional PL1000. Initially set as follows:

Safety shutoff protection — electrical:

- Oil pressure
- Water temperature
- Overspeed
- Crankcase pressure
- Aftercooler temperature
- Air inlet shutoff activated on overspeed or emergency stop included

Alarms — electrical:

- ECU voltage
- Oil pressure
- Water temperature (low and high)
- Overspeed
- Crankcase pressure
- Aftercooler temperature
- Low water level (sensor shipped loose if no mounted expansion tank or radiator)
- Air inlet restriction
- Exhaust stack temperature
- Filter differential pressure (oil and fuel)

Derate — electrical:

- High water temperature
- Crankcase pressure
- Aftercooler temperature
- Air inlet restriction
- Altitude
- Exhaust temperature

Emergency stop pushbutton (on instrument panel)
Alarm switches (oil pressure and water temperature), for connection to customer supplied alarm panel — unwired

Starting and Control

Air silencer and vapor arrestor
Air starting motor

General

Lifting eyes — front and rear
Paint — Caterpillar yellow

ACCESSORY EQUIPMENT

Customer communication module
Jacket water heaters
Mufflers — spark arresting
Primary fuel filter
Fuel cooler, radiator-mounted
Thermo-laminated heat shields for exhaust and turbochargers
Radiator — blower fan, dual core radiator

Additional instrumentation: air cleaner restriction (2), intake manifold temperature, lubricating oil temperature, fuel filter differential
Direct rack control interface
Bypass centrifugal oil filter
Metal particle detector
Fuel/water separator
Communications: J1939, MODBUS, and ethernet



GENERATOR DATA

	60 Hz Generator Offerings Available	
ekW Rating	1245	1245
kVA Rating	1778	1556
Oversize kVA Rating	2150	1750
rpm	1200	1200
Rated PF	0.7	0.8
Temperature Rise	80°C @ 50°C Ambient	80°C @ 50°C Ambient
Insulation Class	H	H
Overload	50% / 2 min	50% / 2 min.
Excitation	Permanent Magnet	Permanent Magnet
Voltage	600	600
Voltage Regulator	Optional	Optional
Configuration	2-Bearing, Close-Coupled	2-Bearing, Close-Coupled
Coastal Protection	Yes	Yes
Space Heater	Included	Included
Construction	Form Wound	Form Wound
Frame Size	868	867

ALTITUDE CAPABILITY

Approximate Power (bhp) as a function of Altitude and Inlet Manifold Temperature																	
Ambient Operating Temp. (°F)	Altitude (feet)																
	15,000	14,000	13,000	12,000	11,000	10,000	9000	8000	7000	6000	5000	4000	3000	2000	1000	0	
50	1296	1353	1411	1472	1535	1599	1666	1735	1750	1750	1750	1750	1750	1750	1750	1750	1750
60	1271	1327	1384	1444	1505	1568	1634	1701	1750	1750	1750	1750	1750	1750	1750	1750	1750
70	1247	1302	1358	1416	1477	1539	1603	1669	1737	1750	1750	1750	1750	1750	1750	1750	1750
80	1224	1278	1333	1390	1449	1510	1573	1638	1705	1750	1750	1750	1750	1750	1750	1750	1750
90	1202	1254	1309	1365	1423	1483	1545	1608	1674	1742	1750	1750	1750	1750	1750	1750	1750
100	1180	1232	1285	1341	1398	1456	1517	1580	1644	1711	1750	1750	1750	1750	1750	1750	1750
110	1160	1210	1263	1317	1373	1431	1490	1552	1615	1681	1748	1750	1750	1750	1750	1750	1750
120	1140	1189	1241	1294	1349	1406	1465	1525	1587	1652	1718	1750	1750	1750	1750	1750	1750
130	1120	1169	1220	1272	1326	1382	1440	1499	1561	1624	1689	1750	1750	1750	1750	1750	1750
Normal	1363	1412	1462	1514	1567	1622	1677	1734	1750	1750	1750	1750	1750	1750	1750	1750	1750



3512C HD LAND ELECTRIC-DRIVE DRILLING MODULE

1305 kW (1750 bhp)

LAND ELECTRIC-DRIVE DRILLING MODULE

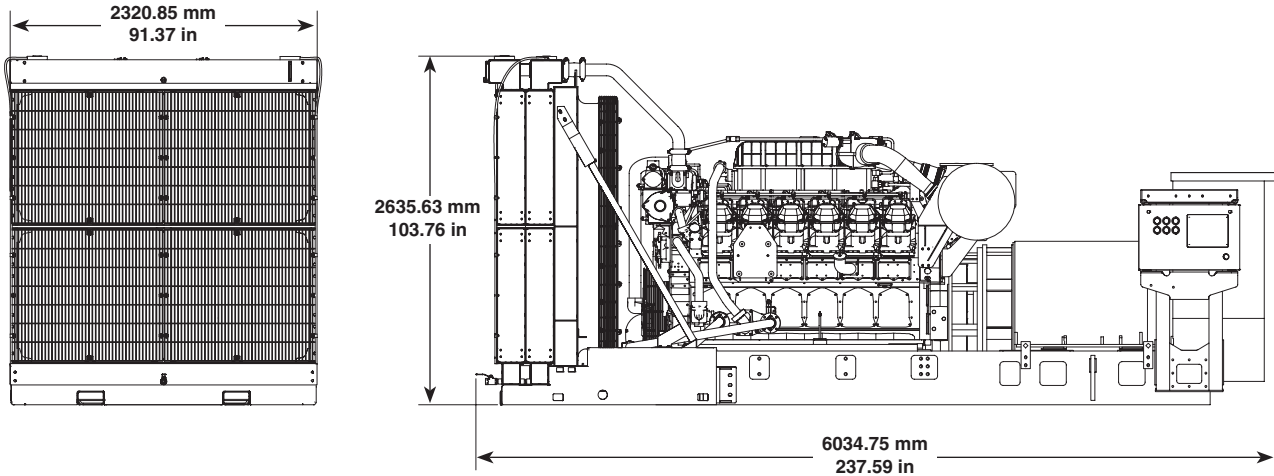

Module Dimensions		
Length	6034.75 mm	237.59 in
Width	2320.85 mm	91.37 in
Height	2635.63 mm	103.76 in
Module Weight (dry)*	16,946 kg	37,360 lb

Do not use for installation design. See general dimension drawings for detail.

*Module includes generator and base.

Please Note: Connection points are expected to remain constant from the 3512C except for exhaust connection point.

RATING DEFINITIONS AND CONDITIONS

Ratings are based on SAE J1995 standard conditions of 100 kPa (29.61 in Hg) and 25°C (77°F). These ratings also apply at ISO3046/1, DIN6271, and BS5514 standard conditions of 100 kPa (29.61 in Hg), 27°C (81°F), and 60% relative humidity. Ratings are valid for air cleaner inlet temperatures up to and including 50°C (122°F).

Fuel consumption has a tolerance of +5% and is based on fuel oil of 35° API [16°C (60°F)] gravity having an LHV of 82 780 kJ/kg (18 390 Btu/lb) when used at 29°C (85°F) and weighing 838.9 g/liter (7.001 lbs/U.S. gal). Fuel consumption shown with all oil, fuel, and water pumps, engine driven.

Information contained in this publication may be considered confidential. Discretion is recommended when distributing. Materials and specifications are subject to change without notice. The International System of Units (SI) is used in this publication.

CAT, CATERPILLAR, their respective logos, ADEM, S•O•S, "Caterpillar Yellow" and the "Power Edge" trade dress, as well as corporate and product identity used herein, are trademarks of Caterpillar and may not be used without permission.