



# C15 ACERT™ Petroleum Engine

400 bkW  
(536 bhp)  
1800-2000 rpm

## Hazardous Location

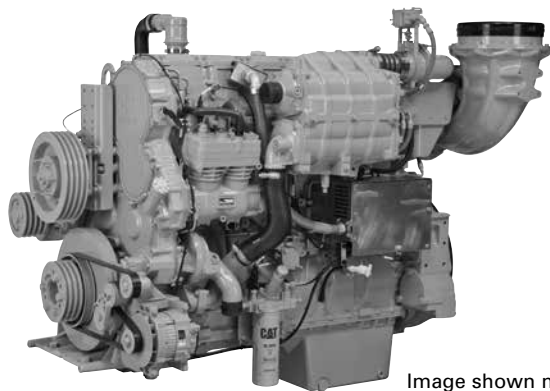

Image shown may not reflect actual engine configuration

## CAT® ENGINE SPECIFICATIONS

### I-6, 4-Stroke-Cycle Diesel

Emissions.....	IMO Tier II Certified, EPA Marine Tier 2 Certified, Marine Tier 3 Certified, EU Stage IIIA for constant speed rating only
Peak Torque at Speed .	2428 N•m (1791 lb-ft) @ 1350 rpm 2122 N•m (1565 lb-ft) @ 1800 rpm EU Stage IIIA only
Bore.....	137 mm (5.4 in)
Stroke .....	171 mm (6.7 in)
Displacement .....	15.2 L (928 in³)
Aspiration .....	Turbocharged-Aftercooled
Governor and Protection .....	Electronic ADEM™ A4
Engine Weight, Net Dry (approximate) .....	1732 kg (3818 lbs)
Capacity for Liquids	
Lube System (refill) .....	34 L (36 U.S. qts)
Cooling System.....	26.9 L (28.4 U.S. qts)
Oil Change Interval .....	500 hours
Rotation (from flywheel end).....	Counterclockwise
Flywheel and Flywheel Housing.....	SAE No. 1
Flywheel Teeth .....	113 (SAE 1)

## FEATURES

### Improving Workforce Efficiency

- Standard factory certifications improve worksite safety
  - Class I Division 2 (NEC 500)
  - Class I Zone 2 (NEC 505)
  - ATEX Directive (94/9/EC) Group II
  - 3G Environments (Zone 2) with Gas Group IIA
  - Electrical IIC and Temperature Class T3
- Electrical harness and connectors are certified as intrinsically safe for Zone 2 and for protection against flame propagation
- Certified flameproof intake system to prevent any internal explosions from propagating to external atmosphere
- Industry-standard ADEM A4 control system improves operator interface
- Fully certified engine for easy integration to other certified components and systems
- Additional NEC/ATEX components available for fail-safe auxiliary system monitoring
  - Customer harness, messenger display, hand throttle control and auxiliary temperature sensors
- Certified optional components for skid integration
  - Class 1 Division 2 alternator, ATEX-approved alternator, gear-driven air compressor, fan belts, and exhaust gas cooler connection option
- Certified automatic engine shutdown system

### Making Your Investment Work Harder

- Factory-certified engines for hazardous location applications allow simplified rig certification for OEM
- Optimized for demanding well service applications
  - Workover, pumping, cementing, blending, and acidizing

- Maintains high power over broad range of operating speeds, improving performance (EU Stage IIIA is only constant speed 1800 rpm)
- Steady torque rise provides superior load acceptance
- Optimized ambient and altitude capabilities for operating flexibility
  - Engine certified to maintain T3 skin temperatures for up to 50°C ambient applications

### Committed to Sustainable Development

- Meets today's emissions requirements for well service applications
  - IMO Tier II, Marine Tier 2, Marine Tier 3 certified, EU Stage IIIA with constant speed rating

### Driving Down Total Cost of Ownership

- World-class reliability and durability
- Factory-certified engines reduce OEM's overall certification costs
- Improved serviceability versus the competition
- Industry-leading component overhaul life
- Rugged Caterpillar testing on all components improves uptime

### Advanced Digital Engine Management

ADEM A4 control system providing integrated ignition, speed governing, protection, and controls, including detonationsensitive variable ignition timing. ADEM A4 has improved: user interface, display system, shutdown controls, and system diagnostics.

### Web Site

For all your petroleum power requirements, visit [www.catoilandgasinfo.com](http://www.catoilandgasinfo.com).



## FEATURES (continued)

---

### Custom Packaging

For any petroleum application, trust Caterpillar to meet your exact needs with a factory custom package. Cat® engines, generators, enclosures, controls, radiators, transmissions, aftertreatment solutions — anything your project requires — can be custom designed and matched to create a one-of-a-kind solution. Custom packages are globally supported and are covered by a one-year warranty after startup.

### Transmissions

- Caterpillar has a full line of engine-transmission packages that can be fully integrated with your axle, hydraulics, and operator interface.
  - C15 ACERT™ Cat optimized transmission matches: CX31-P600, CX35-P800
- Hazardous Location Certification of the Cat transmission is currently the responsibility of the OEM/packager.

### Product Support Offered Through Global Cat Dealer Network

- More than 2,200 dealer outlets
  - Caterpillar factory-trained dealer technicians service every aspect of your petroleum engine
  - Caterpillar parts and labor warranty
- Preventive maintenance agreements available for repair-before-failure options

### Over 80 Years of Engine Manufacturing Experience

Ownership of these manufacturing processes enables Caterpillar to produce high quality, dependable products.

- Cast engine blocks, heads, cylinder liners, and flywheel housings
- Machine critical components
- Assemble complete engine

## STANDARD ENGINE EQUIPMENT

---

### Air Inlet System

Separate circuit aftercooler with ATEX approved shutoff, 90° turbo inlet connection, 304.8 mm (12") hose connection with flame arrestor

### Charging System

24V ATEX approved alternator — LH mounted\*

### Control System

Electronic governing, PTO speed control (only available on variable speed engines), programmable ratings, cold mode start strategy, automatic altitude compensation, power compensation for fuel temperature, programmable low and high idle and TEL, electronic diagnostics and fault logging, engine monitoring and protection system (speeds, temperature, pressure), J1939 broadcast (diagnostic, engine status and control)

### Cooling System

Thermostat and housing — outlet vertical; jacket water pump — gear-driven, centrifugal; RH front water pump inlet; SCAC

### Exhaust System

Right rear turbo exhaust, water cooled turbine housing, carbon steel exhaust manifold — wet

### Flywheels and Flywheel Housing

SAE 1 flywheel housing standard, see price list for flywheel options

### Fuel System

Electronic unit injector; fuel priming pump — upward angled; engine-mounted secondary fuel filter, front-mounted fuel transfer pump — LH front; fuel sample valve — mounted on fuel filter base

### Lube System

Oil cooler; RH oil filter; rear sump 38 L oil pan; valve cover oil fill, optional front oil fill; oil gauges standard with LH and RH access; oil valve sampling on oil filter base; remote mount oil filter kit

### Mounting System

Front support with mounting provision for LH or RH alternators

### Power Take-Off

SAE B options for SCAC and REMAC: single cylinder ATEX air compressor; dual cylinder air compressor, SAE B drive adapter; SAE A drive for REMAC

### Front Engine Accessory Drive

3 v-groove standard — optional 4 and 5 groove 203.2 mm (8.0 in) diameter crankshaft, 17.5 mm (11/16 in) v-belt; optional v-belt or 8-groove accessory drive for 240.39 mm (9.46 in) diameter pulley; ATEX 24V 35 amp alternator — LH and RH mounting poly v-belt; CSA 24V 65 amp alternator — LH and RH mounting poly v-belt; variable fan heights and ratios with 3 and 4 groove fan drives (see Price List)

### General

Vibration damper, lifting eyes, automatic variable timing — electronic, electronic installation kit 70-pin connector (connectors, pins, sockets), literature GP Owner & Operator, paint

\*Water lines with exhaust gas cooler connection w/o transmission cooler



**PERFORMANCE DATA**

Turbocharged-Aftercooled — 1800-2000 rpm

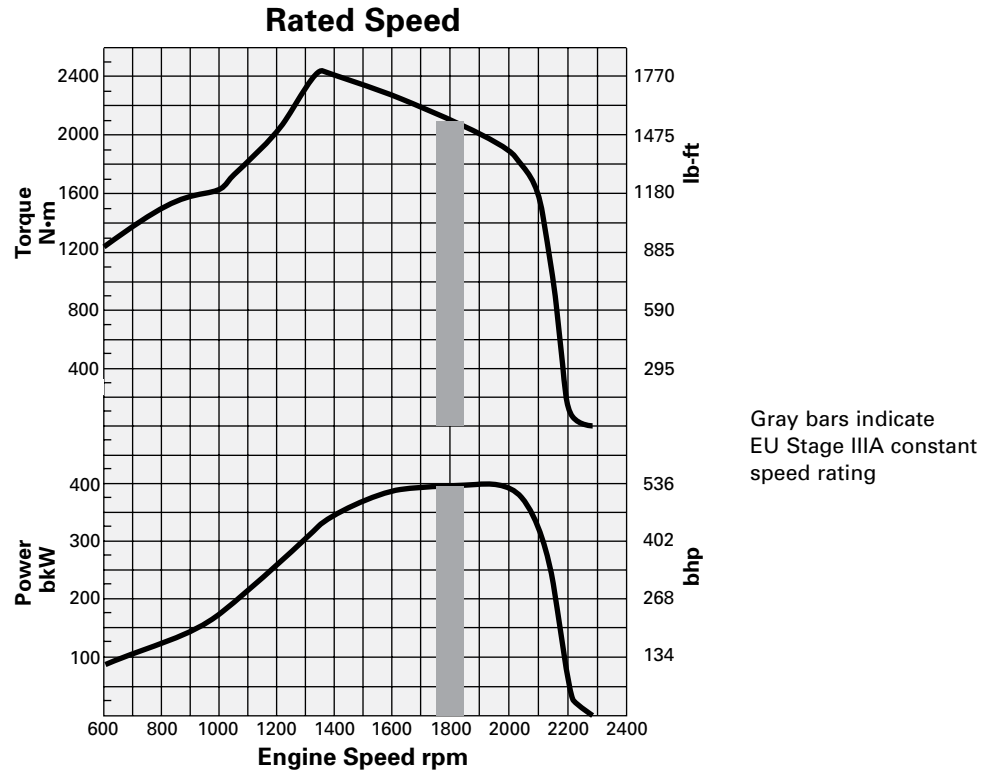

**Peak Power**

**Peak Torque**

Rating	Speed rpm	Peak Power bkW	Peak Power bhp	Speed rpm	Peak Torque N·m	Peak Torque lb-ft
D	2000	400	536	1350	2437	1797
D	1800	400	536	1800	2122	1565

**Emissions**

600-2200 rpm Variable Speed	1800 rpm Constant Speed
IMO Tier II	IMO Tier II
EPA Marine Tier 2 and Tier 3	EU Stage IIIA

**RATING DEFINITIONS AND CONDITIONS**

**D Rating** for service where maximum power is required for periodic overloads (time at full load not to exceed 10% of the duty cycle).

**Engine Performance Diesel Engines — 7 liter and higher** are based on SAE J1995, inlet air standard conditions of 99 kPa (29.31 in Hg) dry barometer and 25°C (77°F) temperature. Performance measured using a standard fuel with fuel gravity of 35° API having a lower heating value of 42 780 kJ/kg (18,390 btu/lb) when used at 29°C (84.2°F) with a density of 838.9 g/L.



**C15 ACERT™**  
**Petroleum Engine**  
400 bkW/536 bhp @ 1800-2000 rpm

**DIMENSIONS**

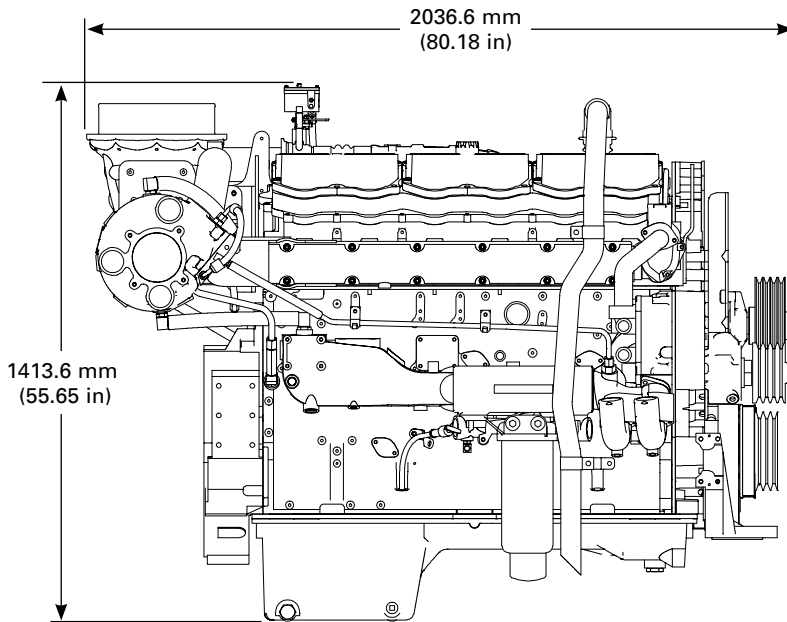

**RIGHT SIDE VIEW**

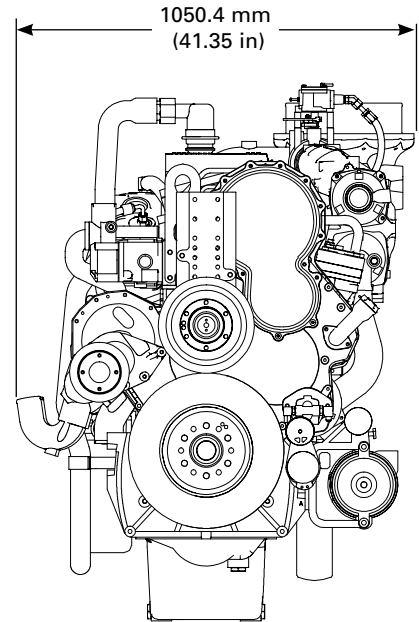

**FRONT VIEW**

DIMENSIONS*		
Length	mm (in)	2036.6 (80.18)
Width	mm (in)	1050.4 (41.35)
Height	mm (in)	1413.6 (55.65)
Shipping Weight	kg (lb)	1732 (3818)

\*Maximum dimensions are shown. Dimensions may be less depending on the alternator, fan adapter, and air shutoff selected.

Materials and specifications are subject to change without notice. The International System of Units (SI) is used in this publication. CAT, CATERPILLAR, their respective logos, ACERT, ADEM, "Caterpillar Yellow" and the "Power Edge" trade dress, as well as corporate and product identity used herein, are trademarks of Caterpillar and may not be used without permission.