



# C32 ACERT™ Petroleum Engine

597-828 bkW  
(800-1110 bhp)  
2100 rpm

**Water-Cooled Manifold  
Hazardous Location**

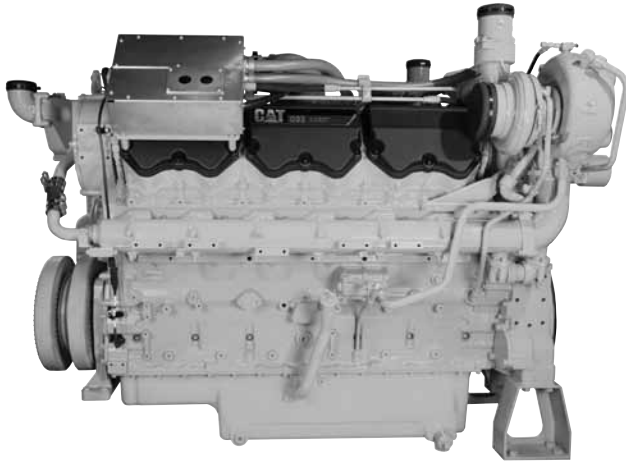

Image is a representation only, and may show optional attachments.

## CAT® ENGINE SPECIFICATIONS

### V-12, 4-Stroke-Cycle-Diesel

Emissions .....	U.S. Non-Road Tier 2 CARB, IMO Tier II, EPA Marine Tier 2
Peak Torque at Speed.....	2776 lb-ft
Bore .....	145 mm (5.7 in)
Stroke .....	162 mm (6.4 in)
Displacement.....	32.1 L (1960 cu. in)
Aspiration .....	Turbocharged-Aftercooled
Governor and Protection.....	Electronic (ADEM™ A4)
Engine Weight, net dry (approx) .....	3152 kg (6950 lb)
Capacity for Liquids	
Lube Oil System (refill) .....	71.2 L (18.8 gal)
Cooling System.....	54.5 L (14.4 gal)
Oil Change Interval.....	250 hours
Rotation (from flywheel end) .....	Counterclockwise
Flywheel and Flywheel Housing ...	SAE No. 0 or SAE No. 1
Flywheel Teeth .....	136

## FEATURES

### Engine Design

- Proven reliability and durability
- 45°C ambient capability\*
- Robust diesel strength design prolongs life and lowers owning and operating costs
- Broad operating speed range
- PTO drive options provide flexible access to auxiliary power for pumps and other needs

### Cat® Hazardous Location Engine

Cat Petroleum Hazardous Location Engines are third-party certified from Caterpillar

- Class I Division 2 (NEC 500)
- Class I Zone 2 (NEC 505)
- ATEX Directive (94/9/EC) Group II, 3G environments (Zone 2) with Gas Group IIA, Electrical IIC, and Temperature Class T3\*\*

### Technology

- Electrical harness containing point-to-point wiring without splices in any power/signal wires
- Electrical harnesses and connectors are overmolded and are routed through urethane tube for protection against impact and vertical flame propagation.
- To meet safety requirements, connectors require the use of a special tool to be disconnected and bear the “do not disconnect while energized” warning.
- Optional ATEX and NEC certified 25-foot customer harness
- ECU is certified as part of the engine to restricted breathing per EN 60079-15. ECU is protected with a stainless steel guard.
- Fuel injector connections at valve cover bases are protected with stainless steel guards

### Advanced Digital Engine Management

ADEM A4 engine management system integrates speed control, air/fuel ratio control and ignition/detonation controls into a complete engine management system with integrated digital ignition, engine protection and monitoring.

\*See TMI for altitude and ambient capability

\*\*ATEX compliant with exceptions — packager responsible to ensure ATEX compliant installation

### Transmissions

The full line of Cat engine/transmission packages can be fully integrated with your axle, hydraulics, and operator interface. Cat transmissions deliver continuous operation under full load, smooth shifting at any speed, and maximum up time, with unmatched durability and easy maintenance.

### Custom Packaging

Trust a Cat factory custom package to meet your exact petroleum application needs. Cat engines, generators, enclosures, controls, radiators, transmissions — anything your project requires — can be custom designed and matched to create a one-of-a kind solution. Custom packages are globally supported and are covered by a one-year warranty after startup.

### Full Range of Attachments

Large variety of factory-installed engine attachments reduces packaging time

### Testing

Every engine is full-load tested to ensure proper engine performance.

### Product Support Offered Through Global Cat Dealer Network

More than 2,200 dealer outlets

Cat factory-trained dealer technicians service every aspect of your petroleum engine

Cat parts and labor warranty

Preventive maintenance agreements available for repair-before-failure options

S•O•S<sup>SM</sup> program matches your oil and coolant samples against Caterpillar set standards

### Over 80 Years of Engine Manufacturing Experience

Ownership of these manufacturing processes enables Caterpillar to produce high quality, dependable products.

- Cast engine blocks, heads, cylinder liners, and flywheel housings
- Machine critical components
- Assemble complete engine

### Web Site

For all your petroleum power requirements, visit [www.catoilandgas.cat.com](http://www.catoilandgas.cat.com).



---

**STANDARD EQUIPMENT**

---

**Air Inlet System**

Dual side-mounted turbochargers — inlet 152.4 mm (6 in) hose connection

**Control System**

Programmable ratings  
Cold mode start strategy  
Automatic altitude compensation  
Power compensation for fuel temperature  
Programmable low and high idle  
Electronic diagnostics and fault logging  
Engine monitoring and protection system (speed, temperature, pressure).  
J1939 Broadcast (diagnostic, engine status and control)  
Electronic governing, PTO speed control  
Certified electrical control system  
Customer interface harness available as optional attachment

**Cooling System**

Thermostats and housing — outlet LH vertical orientation  
Jacket water pump — gear-driven, centrifugal, RH

**Exhaust System**

Exhaust manifold, water-cooled  
Dual turbo, rear turbo exhaust, full marmon connection  
127 mm (5 in), maximum load 10 kg for direct connection to turbo  
Water-cooled center sections

**Flywheels and Flywheel Housing**

Mandatory selection of:  
SAE No. 0 or SAE No. 1 flywheel and housing  
SAE standard rotation

**Fuel System**

MEUI fuel system  
Fuel filter — RH (2 micron high performance)  
Fuel transfer pump  
Fuel priming pump

**Lube System**

Crankcase breather — rear-mounted  
Oil cooler — RH  
Oil filler in RH front gear case  
Oil filter — RH  
Oil level gauge — RH  
Oil pan rear sump

**Mounting System**

Narrow front support

**Power Take-Offs**

Crankshaft pulley — 203.2 mm (8 in) 5 grooves 15.9 (.63 in) wide; 292.1 mm (11.5 in) 1 groove 15.9 (.63 in) wide

**General**

Paint — Cat yellow  
Vibration damper with single pulley  
Lifting eyes  
Automatic variable timing — electronic  
Electronic installation kit 70-pin connector (connectors, pins, socket)

**Mandatory Options**

HP must be specified when ordering  
All engines shipped at 2100 rpm  
Flywheel housing

These engines meet the current IMO emission standards as defined by Regulation 13 of Annex VI to the International Convention for the Prevention of Pollution from Ships, 1973, as modified by the Protocol of 1978, further amended by the Protocol of 1997.

A statement of compliance issued by the United States government's EPA (Environmental Protection Agency) is included in the technical file that is shipped with the engine as proof of our engine's ability to meet IMO emissions requirements. If this technical file is insufficient to meet the customer's requirements, then a GL or CCS IMO emissions certification may be ordered.

---

**OPTIONAL ATTACHMENTS**

---

**Air Compressor****Air Inlet System**

Air cleaner  
Air inlet adapters  
Turbocharger outlet adapters  
Air lines

**Charging System**

Battery chargers  
Charging alternators  
Alternator mounting  
Circuit breakers and mountings

**Cooling System**

Dry charge coolant conditioners  
Thermostat housing  
Coolant level sensor  
Radiator  
Suction fans and blower fans  
Fan adapters  
Fan drives

**Emissions**

IMO certifications

**Exhaust System**

Elbows  
Mufflers

**Fuel Systems**

Electric fuel priming pump

**Instrumentation**

Customer management device  
Interconnect harness  
Gauges and instrument panels

**Lube System**

Oil pans  
Oil service side  
Oil level gauge  
Oil filters  
Lubricating oils

**Mounting System**

Structural steel base  
Engine support — front and rear

**Power Take-Offs**

Auxiliary drive  
Damper pulley  
Hydraulics gear pumps

**Protection System**

Mechanical shutoffs  
Solenoid shutoffs

**Starting System**

Electric starting motors – 12V, 24V  
Battery sets – 24V  
Battery rack and cable  
Starting aids

**Transmission Arrangement**

Transmission water lines  
Transmission cooler



**PERFORMANCE CURVES**

Turbocharged-Aftercooled

Well Service Rating — 746 bkW (1000 bhp) @ 2100 rpm\*

DM9686-01

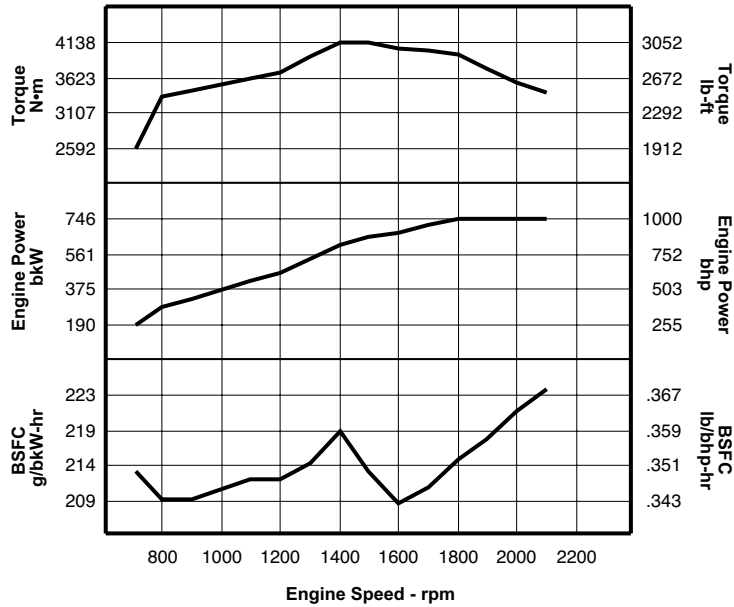

Heat Rejection Data										
Engine Speed rpm	Engine Power		Rej to JW		Rej to Atmos		Rej to Exh		From Aft Clr	
	bkW	bhp	bkW	Btu/min	bkW	Btu/min	bkW	Btu/min	bkW	Btu/min
2100	746.0	1000.4	512	29117	128	7279	569	32359	167	9497
1900	746.0	1000.4	496	28207	130	7393	561	31904	160	9099
1700	716.0	960.2	452	25705	113	6426	508	28890	136	7734
1500	650.0	871.7	426	24227	112	6369	461	26217	108	6142
1300	535.0	717.4	381	21667	95	5403	383	21781	60	3412
1100	417.0	559.2	309	17573	77	4379	301	17118	23	1308
800	280.0	375.5	185	10521	43	2445	236	13421	7	398

\*Other engine ratings are available. Please contact dealer for performance data.



# C32 ACERT™

# PETROLEUM ENGINE

597-828 kW (800-1110 bhp)

## PETROLEUM ENGINE

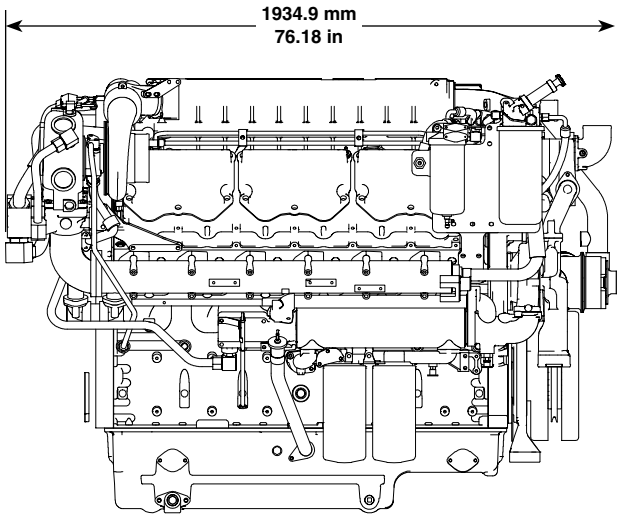

**Right Side View**

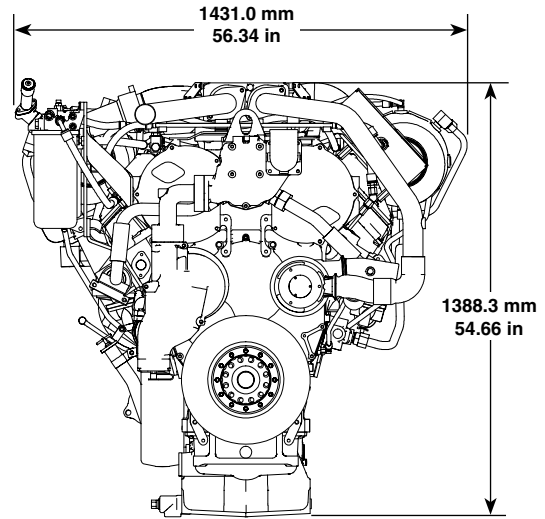

**Front View**

Engine Dimensions		
<b>Length</b>	1934.9 mm	76.18 in
<b>Width</b>	1431.0 mm	56.34 in
<b>Height</b>	1388.3 mm	54.66 in
<b>Engine Weight (dry)</b>	3152 kg	6950 lb

**Note:** Do not use for installation design. See general dimension drawings for detail (Drawing #310-1652).

## RATING DEFINITIONS AND CONDITIONS

**Engine Performance** is corrected to inlet air standard conditions of 99 kPa (29.31 in Hg) dry barometer and 25°C (77°F) temperature. These values correspond to the standard atmospheric pressure and temperature as shown in SAE J1995.

Performance measured using a standard fuel with fuel gravity of 35 degrees API having a lower heating value of 42,780 kJ/kg (18,390 BTU/lb) when used at 29°C (84.2°F) where the density is 838.9 g/L (7.001 lb/U.S. gal).

The corrected performance values shown for Cat engines will approximate the values obtained when the observed performance data is corrected to SAE J1995, ISO 3046-2, ISO 8665, ISO 2288, ISO 9249, ISO 1585, EEC 80/1269, and DIN 70020 standard reference conditions.

Information contained in this publication may be considered confidential. Discretion is recommended when distributing. Materials and specifications are subject to change without notice. The International System of Units (SI) is used in this publication. CAT, CATERPILLAR, their respective logos, ACERT, ADEM, S•O•S, "Caterpillar Yellow" and the "Power Edge" trade dress, as well as corporate and product identity used herein, are trademarks of Caterpillar and may not be used without permission.