

# MOTOR CONTROL CENTERS

**CATALOG**

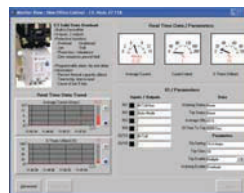

- **CENTERLINE® 2100**  
**Motor Control Centers**



LISTEN.  
THINK.  
SOLVE.®

**Quick Index**

<b>Bulletin Number</b>	<b>Page Number</b>	<b>Bulletin Number</b>	<b>Page Number</b>	<b>Bulletin Number</b>	<b>Page Number</b>	<b>Bulletin Number</b>	<b>Page Number</b>	
2102.....	35	2123F.....	48	2162T.....	171	2183J.....	197	
2103.....	35	2126E.....	52	2163Q.....	149	2183L.....	197	
2106.....	38	2126F.....	52	2163R.....	160	2190.....	57	<b>General Information</b> ..... 1
<b>2106 Space Saving NEMA</b> .....	40	2126J.....	52	2163T.....	171	2191F.....	62	<b>Sections with Full Cabinet Mounting Plates, SCI</b> ..... 18
2107.....	38	2126K.....	52	2164Q.....	176	2191M.....	62	<b>IntelliCENTER Technology</b> ..... 29
<b>2107 Space Saving NEMA</b> .....	40	2127E.....	52	2164R.....	181	2192F.....	69	<b>Miscellaneous Units</b> ..... 99
2112.....	42	2127F.....	52	2165Q.....	176	2192M.....	69	<b>Sections with Full Cabinet Mounting Plates, SCII</b> ..... 99
<b>2112 Vacuum</b> .....	44	2127J.....	52	2165R.....	181	2193F.....	73	<b>Unpopulated Plug-in Units</b> ..... 102
<b>2112 Space Saving NEMA</b> .....	46	2127K.....	52	2180E.....	197	2193LE.....	82	<b>DeviceNet Power Supplies and Network Linking Devices</b> ..... 104
2113.....	42	2154H.....	130	2180J.....	197	2193M.....	73	<b>Configuration Tables</b> ..... 205
<b>2113 Vacuum</b> .....	45	2154J.....	133	2180L.....	197	2193PP.....	84	<b>Hardware Kits</b> ..... 213
<b>2113 Space Saving NEMA</b> .....	46	2155H.....	130	2181B.....	201	2195.....	87	<b>Appendix</b>
2122E.....	48	2155J.....	133	2182E.....	197	2196.....	87	<b>Dimensions</b> ..... 221
2122F.....	48	2160R.....	147	2182J.....	197	2197.....	87	<b>Heater Element Selection Tables</b> ..... 227
2123E.....	48	2162Q.....	149	2182L.....	197	2196Z.....	87	<b>Full Load Currents</b> ..... 232
		2162R.....	160	2183E.....	197	2197Z.....	87	<b>Interrupting Capacity Ratings</b> ..... 234
								<b>Short Circuit Withstand Ratings</b> ..... 235
								<b>Index</b> ..... 249

<b>General Information</b>	<b>1</b>
<b>Vertical Sections and IntelliCENTER® Technology</b>	<b>2</b>
<b>Units</b>	<b>3</b>
<b>Contactor and Starter Units</b>	<b>4</b>
<b>Metering Units</b>	<b>5</b>
<b>Main and Feeder Units</b>	<b>6</b>
<b>Lighting and Power Panel Units</b>	<b>7</b>
<b>Transformer Units</b>	<b>8</b>
<b>Miscellaneous Units</b>	<b>9</b>
<b>Factory-Installed Options, Modifications, Accessories for Contactors and Starters, Metering, Mains and Feeders, Lighting and Power Panels, Transformer and Miscellaneous Units</b>	<b>10</b>
<b>Factory-Installed Options, Modifications, Accessories for Space Saving NEMA Starter Units</b>	<b>11</b>
<b>Combination Soft Starter (SMC) Units</b>	<b>12</b>
<b>Factory-Installed Options, Modifications, Accessories for Combination Soft Starter (SMC) Units</b>	<b>13</b>
<b>Variable Frequency AC Motor Drive Units</b>	<b>14</b>
<b>Factory-Installed Options, Modifications, Accessories for Combination Variable Frequency AC Motor Drive Units</b>	<b>15</b>
<b>Programmable Controller Units and Marshalling Panels</b>	<b>16</b>
<b>Factory-Installed Options, Modifications, Accessories for Programmable Controllers and Marshalling Panels</b>	<b>17</b>
<b>Configuration Tables</b>	<b>18</b>
<b>Hardware and Kits</b>	<b>19</b>
<b>Appendix</b>	<b>20</b>
<b>Index</b>	<b>21</b>

<b>1</b>	<b>General Information</b>
<b>2</b>	<b>Vertical Sections and IntelliCENTER® Technology</b>
<b>3</b>	<b>Units</b>
<b>4</b>	<b>Contactor and Starter Units</b>
<b>5</b>	<b>Metering Units</b>
<b>6</b>	<b>Main and Feeder Units</b>
<b>7</b>	<b>Lighting and Power Panel Units</b>
<b>8</b>	<b>Transformer Units</b>
<b>9</b>	<b>Miscellaneous Units</b>
<b>10</b>	<b>Factory-Installed Options, Modifications, Accessories for Contactors and Starters, Metering, Mains and Feeders, Lighting and Power Panels, Transformer and Miscellaneous Units</b>
<b>11</b>	<b>Factory-Installed Options, Modifications, Accessories for Space Saving NEMA Starter Units</b>
<b>12</b>	<b>Combination Soft Starter (SMC) Units</b>
<b>13</b>	<b>Factory-Installed Options, Modifications, Accessories for Combination Soft Starter (SMC) Units</b>
<b>14</b>	<b>Variable Frequency AC Motor Drive Units</b>
<b>15</b>	<b>Factory-Installed Options, Modifications, Accessories for Combination Variable Frequency AC Motor Drive Units</b>
<b>16</b>	<b>Programmable Controller Units and Marshalling Panels</b>
<b>17</b>	<b>Factory-Installed Options, Modifications, Accessories for Programmable Controllers and Marshalling Panels</b>
<b>18</b>	<b>Configuration Tables</b>
<b>19</b>	<b>Hardware and Kits</b>
<b>20</b>	<b>Appendix</b>
<b>21</b>	<b>Index</b>



**CENTERLINE® 2100 Motor Control Center**

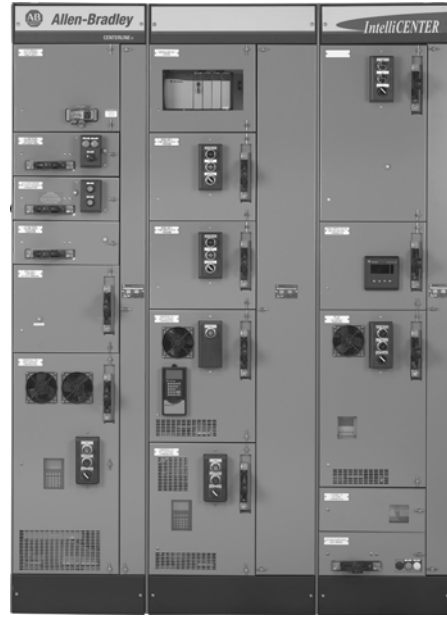

**CENTERLINE® 2100 Motor Control Center with IntelliCENTER Technology**

## Publication Overview

Publication 2100-CA001x-EN-P is a catalog used for CENTERLINE® 2100 Motor Control Centers (MCCs).

## Footnotes

While using this publication, please read all footnotes throughout the publication. Footnotes contain necessary information about the configuration and limitations of sections, units and options being offered.

## Other Resource Publications for CENTERLINE 2100 Motor Control Centers

Publication	Title
2100-SR012x-EN-P	CENTERLINE 2100 MCC Specification Guide
2100-SR003x-EN-P	CENTERLINE 2100 MCC Specification Checklist
2100-4.2	Mains and Incoming Lines Dimension
2100-IN012x-EN-P	CENTERLINE 2100 User Manual
2100-6.0.2	Renewal Parts Publication
2100-AT003x-EN-P	Power System Configuration Considerations for Selection of CENTERLINE 2100 MCCs
2100-SR008x-EN-P	DeviceNet Specification Guide
2100-TD019x-EN-P	DeviceNet Hardware Manual

Contact your local Rockwell Automation sales representative, Allen-Bradley distributor or visit [www.rockwellautomation.com/literature](http://www.rockwellautomation.com/literature).

## CENTERLINE 2100 MCC Applications

CENTERLINE 2100 MCCs are suitable for use on 3-phase, 3-wire or 4-wire, Wye connected power systems, rated 600 V or less, 50 or 60 hertz, which have a solidly grounded neutral. CENTERLINE 2100 MCCs may also be used on other power system configurations, however, some units and options may not be available. Refer to Appendix page 247 for additional information.

## Service and Storage Conditions

CENTERLINE 2100 MCCs conform to NEMA standard ICS 1-1993 for service and storage conditions. All MCCs should have an ambient operating temperature above 0°C but shall not exceed 40°C with up to 95% non-condensing humidity. If the equipment is stored, the ambient temperature shall be above -30°C but shall not exceed 65°C. In addition, MCCs have an altitude class of 2km. The altitude class of 2 km designates equipment for installation where the altitude does not exceed 2000 meters (6600 feet). For installation above 2000 meters, Contact your local Rockwell Automation Sales Office for derating requirements.

## UL/cUL/CSA Marking

CENTERLINE 2100 MCCs are listed by Underwriters Laboratories, Inc. (file number E49289) as complying with Standard Safety UL 845 (UL) and either listed by Underwriters Laboratories, Inc. or certified by Canadian Standards Association (CSA) as complying with standard C22-2, No. 254-05 (cUL or CSA). CENTERLINE 2100 MCCs also meet the requirements in Mexican standard for MCCs, NMXJ-353-ANCE-2006. The MCC product, sections and units will therefore carry the respective marking unless otherwise indicated in the footnotes on the various pages in this publication.

## ISO 9001 Certification

The facilities that develop and manufacture CENTERLINE 2100 MCCs are located in Milwaukee and Richland Center, Wisconsin, Cambridge, Ontario, Canada, Tecate, Mexico and Guadalupe, Mexico. All facilities have been certified to be in conformance to the requirements of Quality Management System ISO 9001. These facilities presently are certified by Det Norske Veritas to ISO 9001: 2000, certificate number CERT-9379-2004-AQ-HOU ANAB, effective May 30, 2007.

## CE Marking

The European Union (EU) has established a program whereby products are tested and qualified to meet its harmonized standards and to fulfill the EN Directives. Upon completion of this testing and qualification, special documentation is required so the products may bear CE marking. Included with this program is the requirement for special instruction literature, product labeling, quality programs, special design requirements, etc. Generally, the CENTERLINE 2100 MCC product can fulfill these requirements, but due to the customization that is required, the CE marking of the product is available only on the Engineered delivery program. In case of variable frequency drives (as well as other solid-state devices), the EU deemed it necessary to add an EMC directive (2004/108/EC). This directive requires more stringent RF emission and immunity standards than normal. To meet these requirements and carry the CE mark, the CENTERLINE 2100 drive packages can be adapted with EMC tested RFI filters and additional shielding hardware. These special packages may require larger MCC enclosures. Note: The CE requirement is for the European Union/Community and is not a mandate for other parts of the world. For more information, visit <http://www.ab.com/certification/#cemark>.

## IEC 60439

The CENTERLINE 2100 structures and many units fulfill IEC 60439 type tested assembly (TTA) and unit requirements. Should custom designs and modifications be required, these can be qualified to IEC 60439 as partially pre-tested assembly (PTTA) and unit requirements.

## American Bureau of Shipping (ABS)

CENTERLINE 2100 MCCs have fulfilled the requirements and are approved by the American Bureau of Shipping (certificate 99-SB55875-X). CENTERLINE 2100 MCCs do meet ABS shipping requirements, but due to required customization, ABS maritime shipping is available only on the Engineered program.

## NEMA Defined

NEMA—National Electrical Manufacturers Association.

## NEMA Class

The following is a description of Class I, as paraphrased from NEMA standard ICS 18-2001: Class I motor control centers shall consist of mechanical groupings of combination motor control units, feeder tap units, other units and electrical devices arranged in a convenient assembly. They include connections from the common horizontal power bus to the units. They do not include interwiring or interlocking between units or to remotely mounted devices, nor do they include control system engineering. Only diagrams of the individual units are supplied.

NEMA Class II interwiring offers the addition of interlocking and wiring between units as specifically described in overall control system diagrams supplied by the purchaser. Contact your local Rockwell Automation Sales Office for availability.

## NEMA Type

Class I motor control centers can be provided in NEMA Type A or B construction:

- Type A—User's power and control connections are made directly to the device within the unit.
- Type B—Terminal blocks are supplied for user's control termination within unit insert. On NEMA size 1 through 3 starter units and 30 A to 100 A contactors units, terminal blocks are also supplied for user's load terminations (NEMA Type BT). NEMA Space Saving units do not include power terminal blocks (NEMA Type BD).

## NEMA/IEC Enclosure Comparison

The following table is a comparison of Allen-Bradley CENTERLINE 2100 MCC NEMA enclosure type numbers to IEC Standard 60529, Classification of Degrees of Protection Provided by Enclosures. The comparison is based on data from tests conducted on the CENTERLINE 2100 MCC enclosures and the NEMA enclosure type test requirements, which meet or exceed the IEC enclosure classification designation test requirements

2

NEMA Type 1 vented (with or without gasketed doors)	IP20
NEMA Type 1 vented with filters (with or without gasketed doors)	IP30
NEMA Type 1 non-vented (without gasketed doors)	IP40
NEMA Type 1 with drip hood = NEMA Type 2 (with or without gasketed doors)	IP41
NEMA Type 3R	IP44
NEMA Type 12 without bottom plates	IP53
NEMA Type 12 with bottom plates	IP54
NEMA Type 4	IP65

## NEMA Enclosure Type Descriptions

### NEMA Type 1:

Type 1 units and sections are intended for indoor use, primarily to provide a degree of protection against contact with the enclosed equipment in locations where unusual service conditions do not exist. The enclosures are designed to meet the rod entry and rust resistance design tests. The enclosure is sheet steel, treated to resist corrosion.

### NEMA Type 1 with gasketed doors (sometimes referred to as 1G):

Type 1 with gasketed unit doors are completely gasketed around the perimeter of the unit doors. All gasketing is closed cell neoprene.

### NEMA Type 3R:

Non-walk-in front mounted only. Door-within-a-door construction. Type 3R units and sections are intended for outdoor use, primarily to provide a degree of protection against falling rain and to avoid damage from the formation of ice on the enclosure. They are designed to meet rod entry, rain, external icing and rust resistance design tests. They are not intended to provide protection against conditions such as dust, internal condensation or internal icing.

### NEMA Type 4:

Non-walk-in front mounted only. Door-within-a-door construction. Type 4 units and sections are designed for indoor and outdoor use, primarily to provide protection against windblown dust and rain, splashing water and hose-directed water. They are also designed to remain undamaged by the formation of ice on the enclosure. They are designed to meet hosedown, external icing, rod entry and rust-resistance design tests. The enclosures are not designed to protect against internal condensation or internal icing.

### NEMA Type 12 <sup>[1]</sup>:

Type 12 enclosures are intended for indoor use, primarily to provide a degree of protection against dust, falling dirt and non-corrosive dripping liquids. They are designed to meet drip, dust and rust resistance tests. They are not intended to provide protection against conditions such as internal condensation.

[1] This publication refers to standard NEMA Type 12 design (i.e., standard sheet steel). For stainless steel NEMA Type 12 enclosures, Contact your local Rockwell Automation Sales Office.

## Delivery Programs

CENTERLINE 2100 MCC products are available on several quick delivery programs and limited to equipment described in this publication.

### SC and PE:

Products indicating SC or PE delivery provide SC-I and PE-I delivery. When options are added or specified for a section, time of delivery is determined by the longest lead time.

### SC-I:

This program offers stock-supported, individual plug-in units as well as vertical sections with field installed plug-in units. This program applies to all plug-in units and vertical sections unless they are labeled SC-II. The SC-I program provides the quickest delivery.

### SC-II:

This program offers stock-supported vertical sections, with factory-installed units for a completely assembled MCC. This is either SC or SC-II. Units specifically labeled SC-II must be factory installed and are not for plug-in installation in the field.

### PE-I and PE-II:

Shading indicates equipment that is offered on the PE-I or PE-II program. These programs offer a broad range of pre-engineered units and sections and a slightly longer lead time than our SC programs. While PE-I units are available for plug-in installation in the field, units specifically labeled PE-II must be factory installed.

### Engineered:

Equipment or modifications not available on the above delivery programs may be available on the Engineered program. This program offers the complete line of assembled motor control equipment, custom wired for the customer's needs. Additionally, a wide range of special control and bus options are offered, making this our most versatile delivery program. Contact your local Rockwell Automation Sales Office or Allen-Bradley distributor for more information.

**Delivery Time** will be based on the equipment with the longest lead time. Quicker delivery is possible when equipment is separated and ordered according to the delivery category. For example, if an order has one engineered plug-in unit and the remaining units and sections are SC-II - order the engineered unit as a separate item. The SC-II units and sections will ship on the SC-II delivery program and only the engineered unit will have a longer delivery time.

## Delivery Program Indications

Delivery programs are indicated in the right column on all pages. PE delivery program is indicated by shaded cells.

3

Catalog Number Wiring Type B—Class 1 NEMA Type 1 and Type 1 w/ gasket	Delivery Program
2112B-FA_ _	SC
2112BB-GA_ _	PE-II

## Seismic Applications

CENTERLINE 2100 MCCs meet the requirements for Uniform Building Code (UBC) Zone 4 seismic applications and comply with IBC 2000 & 2006 seismic criteria. See Appendix page 246 for more information.

## DeviceNet™ Products

Look for DeviceNet capable devices throughout this publication to find units and options that are DeviceNet ready to use in CENTERLINE 2100 MCCs with IntelliCENTER technology. The components used in these units are DeviceNet compatible and ODVA certified. Also, the installation conforms to the rules and guidelines of The Planning and Installation Manual for DeviceNet. IntelliCENTER technology (power supply unit, built-in cabling system, unit cables, etc.) is UL and cUL listed and meets the requirements of a Class 1 power limited circuit (in Canada, Class 1 extra-low-voltage power circuit). Per NEC, this circuit is supplied from a source that has a rated output of not more than 30 Volts and 1000 Volt-Amperes. The power supply unit has an 8A, 24V output and the DeviceNet cabling is rated 8A, 600V. See NEC Article 725 for more detailed information.

## Type 2 Protection

Short circuit coordination is defined in IEC 60947-4-1. Type 2 protection (also referred to as Type 2 coordination) is obtainable when the fuses are specified and sized according to publication 100-2.8, *Certified Type 2 Short Circuit Coordination with Allen-Bradley Motor Starters*. Only Type 1 coordination is available, other than on specified fuses and circuit breaker units.

## Motor Applications

The Motor Control Center Business has made engineering evaluations for the protective device (circuit breaker or fuse) selection, sizing and setting range based on the protection rules/requirements and motor criteria as stipulated in NEC, NEMA and UL standards (e.g., motor full load currents [FLCs], X/R ratios, lock rotor currents, nominal utilization voltages, etc.). Should the motor application have criteria that deviate from those stated in the aforementioned standards, higher FLC and/or motor inrush currents (greater than 1300% of the nominal FLC) may be experienced (e.g., special motors, non-standard NEMA motors, energy efficient motors, Design E motors, IEC Type N motors, etc.). To address these cases, consult publications 2100-TD001x-EN-P and 2100-TD002x-EN-P (for circuit breaker applications), publication 2100-TD003x-EN-P (for power fuse applications) and the NEC for selection guidance. For further assistance or information, contact your local Rockwell Automation Sales Office.

## Documentation

For assembled motor control centers, the customer is supplied with a copy of the motor control center layout and specification (Form 385) and publication 2100-IN012x-EN-P, *CENTERLINE 2100 Motor Control Centers User Manual*. Publication 2100-IN040x-EN-P, *Receiving, Handling and Storing Motor Control Centers*, is attached to the outside packaging of each shipping block. Information on bus torquing is located on the inside of each vertical wireway door. Documentation for individual units consists of a copy of the unit wiring diagram and installation instructions. Field termination and torquing requirements for units are included on the unit wiring diagrams. This documentation may be located in a centralized wiring diagram holder or other location depending on configuration. Manuals for SMC units, AC drive units, PLC units, etc. are included in a centralized location in each MCC containing these products.

Up to three electronic documentation CDs can be also be provided at no additional cost for each MCC. The CD contains the following:

- Equipment list (elevation, layout specification) drawings
- One-line diagrams (if requested)
- Unit wiring diagrams
- Spare parts list
- User and installation manuals for Rockwell Automation products, supplied in the specific motor control center
- Test reporting

For other documentation, refer to publication 2100-CA003x-EN-E, *Low Voltage Motor Control Centers Documentation Catalog*. For more information, contact your local Rockwell Automation Sales Office.

### Post Shipment Support

- Field Service
- Repair & Modifications
- Code 10 Authorization
- Field Complaints
- Technical Issues
- Warranty Issues
- Domestic and International Renewal Parts Order Services

#### CENTERLINE 2100 MCC:

Email: RAMCCSupport@ra.rockwell.com

Fax: 1-414-382-4045

Phone: 1-440-646-5800

Select Options 2, 5, 4 for Allen-Bradley Brand Products, Motor Control Centers, Hardware Support

#### CENTERLINE 2100 MCCs with IntelliCENTER technology:

Email: RAICTechSupport@ra.rockwell.com

Fax: 1-414-382-0505

Phone: 1-440-646-5800

Select Options 2, 5, 3 for Allen-Bradley Brand Products, Motor Control Centers, IntelliCENTER Support

### General Terms and Conditions of Sale

A copy of the general terms and conditions of sale for CENTERLINE 2100 Motor Control Centers can be obtained at [www.rockwellautomation.com/termsofsale](http://www.rockwellautomation.com/termsofsale).

## Serial Number and Series Letter Information

- From 1980 to 1996, only numbers 600000 to 999999 were used.
- Refer to Series Identification for the implementation date of series letters on sections and units.
- The serial numbers of sections are on the serial plate on the wireway door, for special width sections, the nameplate is located on the section door. On special width sections, the nameplate is located on the section door.
- The serial numbers of units are on the nameplate on the bottom of the units.
- SC-I sections or units will have a series letter after the unit or section catalog number.
- In late 1995, some SC, SC-II and PE orders were entered on PASSPORT.

4

Year	CENTERLINE 2100						Bulletin 2400 Series Units
	Factory Order No.		Serial Numbers		Series		
	Start	End	Start	End	Section	Unit	
1971	704403	807499	959060	971209	A	A	None
1972	807500	121409	971210	983266	A	A	None
1973	121500	346999	983267	996532	A	A	None
1974	347000	539999	996535	999946	A	A	None
			A128502	A483339			
1975	540000	719199	A483344	B677442	A	A	None
1976	719200	933199	B677452	C933199	A-B	A-B	None
1977	933200	268699	D933200	D268699	B	B	None
1978	268700	526199	E268700	E526199	B	B	None
1979	526200	748699	F526200	F748699	B-C	B-C	None
1980	748700	898049	G748700	G898049	C	C	None
1981	898050	661299	H898050	H661299	C-D	C-D-E	None
1982	661300	804249	J661300 <sup>[1]</sup>	J804249 <sup>[1]</sup>	D-E	D-E-F-G	None
1983	804250	948440	K804250	K948440	E-F	F-G	None
1984	948441	693587	L948441	L693587	F	F-G-H-J	None
1985	693588	849069	M693588	M849069	G	H-J	None
1986	849070	612263	N849070	N612263	G-H-J	H-J-K	None
1987	612264	791331	P612264 <sup>[1]</sup>	P791331 <sup>[1]</sup>	J	K	None
1988	791332	991197	R791332 <sup>[1]</sup>	R991197 <sup>[1]</sup>	J	K	None
1989	991198	834534	T991198 <sup>[1]</sup>	T834534 <sup>[1]</sup>	J	K	None
1990	834535	704948	W834535 <sup>[1]</sup>	W704948 <sup>[1]</sup>	J-K	K-M	None
1991	704949	995816	X704949	X995816	K	M	A
1992	995817	732348	Y995817	Y732348	K	M	A-B-C
1993	732349	773410	Z932349	Z773410	K	N	A-C
1994	773411	795559	A773411	A795559	K	N-P	A-C
1995	795560	818971	B795560	B818971	K	N-P	A-C
1996	818972	824311	C818972	C824311	K-L	P-Q	A-C
	NPR624	QBH320	CNPR624	CQBH320			D
1997	824312	N/A	D824312	N/A	L	Q	D
	QBH321	RPH250	DQBH321	DRPH250			
1998	RPH251	TDQ341	ERPH251	ETDQ341	L	R	D
1999	TDQ342	VZM602	FTDQ342	FVZM602	L	R	D
2000	VZM603	XWY931	GVZM603	GXWY931	L	T	D
2001	XWY932	BDPW81	HXWY932	HBDPW81	M	U	D
2002	BDPW82	CBJD56	JBDPW82	JCBJD56	M	U-V	D
2003	CBJD57	CYMV52	KCBJD57	KCYMV52	M	U-V	D
2004	CYNR34	DXSK68	LCYNR34	LDXSK68	M	U-V	D
2005	DXSK69	FYFW68	MDXSK69	MFYFW68	M	X	D
2006	FYFW69	GYTT25	NFYFW69	NGYTT25	M	X-Y	D
2007	GYTT26	JDKT40	PGYTT26	PJDKT40	M	X-Y	D
2008	JDKT41		RJDKT41		M	X-Y	D

[1] Prefix letters I, O, Q, S, U and V are not used.

## Series Identification for Sections

This table gives a brief explanation of the series letter changes that have taken place since the original design of the CENTERLINE 2100 Motor Control Center.

Sections			
Series Letter	Scope	Description of Change	Date Implemented in U.S.
A [1]	—	Original design	February 1971
B [1]	All	Changed terminal blocks	November 1976
C [1]	All	Elimination of external mounting channels	June 1979
D [1]	All	Reverse fed 2192 and 2193	April 1981
E [1]	All	Redesign gasketing	October 1982
F [1]	All	Modified top horizontal wireway pan to accept units with handle interlock in topmost space factor	October 1983
G [1]	42K	42K bracing—incorporates new bus support and cover	January 1985
G [1]	65K	65K bracing—incorporates new bus support and cover	July 1985
H	All	New hinge design	January 1986
J	All	Changed handle, operating mechanism and circuit breaker to Cutler-Hammer Series C, 150A, 250A and 400A frame	October 1986
K	All	Changed to new unit grounding system	May 1990
L	All	Changed to new 600A-1200A circuit breaker operating mechanism	May 1996
M	All	Changed to serpentine DeviceNet cabling system	May 2001

[1] Replacement and renewal parts are no longer supported. Consult MCC Technical Support.

Complete new series units with comparable features and options can be retrofitted into any series of structures as shown in the table on 8.

## Section Nameplate Data

When communicating with Rockwell Automation about a particular Allen-Bradley motor control center, the catalog number or serial number and series letter are required to properly identify the equipment. Refer to publication 2100-IN012x-EN-P, *CENTERLINE Motor Control Centers User Manual*, for more information.

Each vertical section has a nameplate (see the figure below) located on the vertical wireway door. On special width sections, the nameplate is located on the section door. Information on the section nameplate includes:)

- Catalog number (serial number)
- Series letter of the section
- Maximum bus bar voltage and current rating
- Section location number

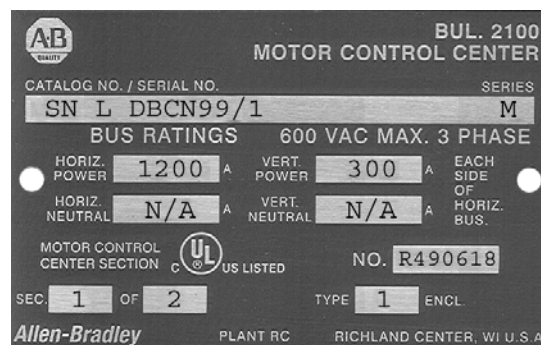

## Unit Label Data

When communicating with Rockwell Automation about a particular Allen-Bradley motor control center, the catalog number or serial number and series letter are required to properly identify the equipment. Refer to publication 2100-IN012x-EN-P, *CENTERLINE Motor Control Centers User Manual*, for more information.

Each unit has a unit label located inside the unit on the bottom plate. See the figure below. Information on the unit nameplate includes:

- Serial number
- Series letter
- Factory order number
- Catalog string number
- Unit location
- System voltage

### Unit Label Data for units shipped on the SC or PE Delivery Programs

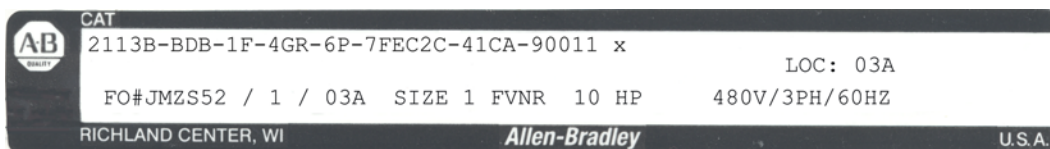

NOTE: CAT number for units supplied on the

Engineered Delivery Program will have a unique catalog number based on the factory order number. e.g. YULDBCN99/1AF (assembled MCCs) or 2100U-LDBCN99/1 (individually ordered units).

## Series Identification for Units

This table gives a brief explanation of the series letter changes that have taken place since the original design of the CENTERLINE 2100 Motor Control Center.

6

Units			
Series Letter	Scope	Description of Change	Date Implemented in U.S.
A <sup>[1]</sup>	—	Original design	February 1971
B <sup>[1]</sup>	All sizes	Changed terminal blocks	November 1976
C <sup>[1]</sup>	All sizes	Changed handle mechanism to Cutler-Hammer MCPs	June 1979
D <sup>[1]</sup>	Size 5	Changed from ITE to A-B 400A disconnect	April 1981
E <sup>[1]</sup>	All sizes	Changed from Bulletin 709 series K starters to Bul. 500 line starters	April 1981
F <sup>[1]</sup>	All sizes	Redesign of gasketing, wraparound and unit support pan for Bulletin 700 line	October 1982
G <sup>[1]</sup>	All sizes	Redesign of gasketing, wraparound and unit support pan for Bulletin 500 line	October 1982
H <sup>[1]</sup>	All sizes	Changed to new door, CB mechanism and control station	April 1984
J <sup>[1]</sup>	Size 5	Changed to Bulletin 500 series L	October 1984
	Size 3	Changed to new PCP 100A disconnect	December 1988
	Size 6	Changed to Bulletin 500 series B starters	October 1988
K	Size 1-5 CB units and size 1-2 disc units	Changed handle, operating mechanism and circuit breaker to Cutler-Hammer Series C, 150A, 250A and 400A frame	October 1986
L	21A through 54A	Changed to Bulletin 100 line contactors in 21A, 30A and 45A SMC units and original design 24A, 35A and 54A SMC units	November 1989
M	All sizes	Changed to new unit grounding system and 600A, 800A and 1200A bolted pressure switch	May 1990
N	All sizes	Changed to PCP 200A and 400A disconnect, rerated vacuum Bulletin 2112 and 2113 and new pilot device offerings	January 1993
P	0.5 SF CB units 2103L, 2113, 2193	External auxiliary on circuit breakers	April 1994
Q	All sizes and ratings	New disconnect external auxiliary contacts and new 600A-1200A circuit breaker operating mechanism	May 1996
R	SMC units	Redesign and upgrade of ratings for 24A-500A SMC-2 and SMC-PLUS units. Original design of SMC Dialog Plus units.	August 1997
	1200A 2193	Redesign of 1200A, 2193F and 2193M units	November 1997
	800A 2193	Changed circuit breakers to MDL Frame	November 1998
	225A 2193F	Changed circuit breakers from J Frame to F Frame	October 1999
T	2000A 2193	Changed to Flange Mounted Operating Handle	November 2000
	All sizes	Changed the Bulletin 800MR and Bul. 800T-PS pilot devices to Bulletin 800Es	
U	All 1.5 space factor units	Changed unit bottom plate	July 2001
	All except 2100-SD1	Changed to new Bulletin 1497 control circuit transformer	
V	2100-SD1	Changed smoke detector head and base components	November 2001
	2162Q, 2163Q, 2164Q, 2165Q	Redesign of 240-480V PowerFlex 70 and release of 600V PowerFlex 70	April 2002
	2162R, 2163R, 2164R, 2165R	Original release of PowerFlex 700	Beginning July 2002
	2154H, 2155H	Original release of SMC-3	Beginning November 2002
	2154J, 2155J	Original release of SMC-Flex	Beginning April 2004
	2112, sizes 3, 4 and 5	Redesign to reduced space factor with Class J fuse clip	April 2004
	2162T, 2163T	Original release of PowerFlex 40	September 2004
X	2107, 2113, size 3	Reduced space factor	April 2005
	2162Q, 2163Q	Reduced space factor, changed CCT with integral fuses	April 2005
Y	All sizes	800F Pilot Devices	August 2005
	2154J, 2155J, 108 A and 135 A	Redesign to change units from frame mounted to plug-in design	March 2006

[1] Replacement and renewal parts are no longer supported. Consult MCC Technical Support.

Complete new series units with comparable features and options can be retrofitted for any series of structures as shown in the table on page 8.

## Series Lettering—Units and Sections

When using sections in conjunction with units of different series letters, consult the MCC Modifications for Unit and Structure Compatibility table below. All sections in this publication are series letter L; all units are series letter Q and later. In 1982, modifications were made to improve the integrity of the gasketing between the unit door and structure of NEMA Type 1 with gasket and Type 12 sections. This has been accomplished by gasketing the structure instead of the unit door. The change applies to all CENTERLINE 2100 units with series letter F and later and all sections series letter E and later. Also, when series H and later units are installed in a series A through E section in the topmost unit location, a new top horizontal wireway pan is required.

### MCC Modifications for Unit and Structure Compatibility

7

If Mounted in this Type of Section <sup>[1],[2]</sup>	Plug-In Units		No Additional Parts Required	Requires Style 1 Unit Support Pan	Requires Style 3 Unit Support Pan	Requires Style 3 Unit Support Pan w/ Bushing	Requires Alternate Top Horizontal Wireway Pan	Requires Door Gasketing Kit	Requires Retrofit Kit <sup>[3]</sup>	Requires Ground Bus Kit <sup>[4]</sup>
	Space Factor	Series								
			—	2100H-UAJ1 See page 216	2100H-UA1 2100H-UJ1 See page 216	2100H-USPA1 2100H-USPJ1 See page 216	2100H-NA4A1 2100H-NA4J1 2100H-NA4A2 2100H-NA4J2 See page 213	2100-GJ10 See page 213	2100H-R1 2100H-R2 See page 217	2100H-GS1 See page 214
NEMA Type 1 Series A-D <sup>[5]</sup>	1.0 or larger	A-E <sup>[6]</sup>	✓	—	—	—	—	—	—	—
		F-L <sup>[5]</sup>	—	✓	—	—	—	✓ <sup>[6]</sup>	—	—
		M or later <sup>[7]</sup>	—	✓	—	—	—	✓ <sup>[6]</sup>	—	✓
NEMA Type 1 Series E-J <sup>[5],[8]</sup>	0.5 <sup>[2]</sup>	N or later	—	—	—	✓	—	—	✓	—
	1.0 or larger	A-E <sup>[5]</sup>	—	—	✓	—	—	—	—	[4]
		F-L <sup>[5]</sup>	✓	—	—	—	—	—	—	—
NEMA Type 1 Series K or later	0.5 <sup>[2]</sup>	N or later	✓	—	—	—	—	—	—	—
	1.0 or larger	A-L <sup>[5]</sup>	—	—	✓	—	—	—	—	[4]
		M or later	✓	—	—	—	—	—	—	—
NEMA Type 1 w/ gasket or Type 12 Series A-D	1.0 or larger	A-E <sup>[5]</sup>	✓	—	—	—	—	—	—	—
		F-L <sup>[5]</sup>	—	✓	—	—	—	✓ <sup>[6]</sup>	✓	—
		M or later	—	✓	—	—	—	✓ <sup>[6]</sup>	✓	✓
NEMA Type 1 w/ gasket or Type 12 Series E-J <sup>[8]</sup>	0.5 <sup>[2]</sup>	N or later	—	—	—	✓	—	—	✓	✓
	1.0 or larger	A-E <sup>[5]</sup>	—	—	✓	—	—	—	—	[4]
		F-L <sup>[5]</sup>	✓	—	—	—	—	—	—	—
NEMA Type 1 w/ gasket or Type 12 Series K or later	0.5 <sup>[2]</sup>	N or later	✓	—	—	—	—	—	—	—
	1.0 or larger	A-L <sup>[5]</sup>	—	—	✓	—	—	—	—	[4]
		M or later	✓	—	—	—	—	—	—	—

- [1] When installing unit in topmost location in vertical section, care must be taken to comply with the National Electrical Code 6'7" (2.0 m) unit handle-to-floor height limitation. A unit operating handle extender (2100H-NE1) is available which provides 3" (76.2 mm) added height flexibility. See page 213 for catalog number.
- [2] When CENTERLINE 2100, 0.5 space factor or Space Saving NEMA Starter plug-in units are ordered unassembled or ordered for existing sections, a centralized wiring diagram holder kit (2100H-WDH) should be ordered. See page 214.
- [3] Permits installation of 0.5 space factor or Space Saving NEMA Starter plug-in units in existing series E through J CENTERLINE 2100 vertical sections. Refer to page 217 for information.
- [4] A ground strap can be used to ground units rather than installing a ground bus. See publication 2100-IN014x-EN-P.
- [5] Replacement and renewal parts are no longer supported. Consult MCC Technical Support.
- [6] Required only if series F or later 1.0 space factor or larger CENTERLINE 2100 unit is installed in topmost location of series A through E vertical sections.
- [7] Consult MCC Technical Support for assistance with possible door hinge requirements.
- [8] Series E-J sections cannot accommodate 0.5 space factor or Space Saving NEMA Starter plug-in units in bottom-most unit location.

Circuit Breaker Suffix Letter Designation

8

Type of Circuit Breaker	Catalog Number Designation		Circuit Breaker Frame Type									
	Old	New	63A	150A	225A <sup>[1]</sup>	225A	250A	400A	600A <sup>[2]</sup>	800A <sup>[2]</sup>	1200A <sup>[2]</sup>	2000A <sup>[2]</sup>
Standard I.C. Instantaneous Trip Only	W	—	—	—	—	—	—	—	—	—	—	—
Standard I.C. Instantaneous Trip Only	WG	—	GMCP	—	—	—	—	—	—	—	—	—
High I.C. Instantaneous Trip Only	—	CA	—	HMCP MCP	—	—	HMCP MCP	HMCP MCP	HMCP MCP	—	—	—
Instantaneous Trip Only with Current Limiter	WC	—	—	—	—	—	—	—	—	—	—	—
High I.C. Instantaneous Trip with Current Limiter	—	CC	—	HMCP-EL MCP-EL	—	—	—	—	—	—	—	—
Standard I.C. Inverse Time (Thermal Magnetic or Electronic)	WT	CT	—	FDB	FD	JD JD3D	JD JD3D	KD K3D	LD	MDL	—	—
Standard I.C. Inverse Time (Thermal Magnetic or Electronic)	WT, CF	—	—	—	—	—	—	—	—	MDS	—	—
Medium I.C. Inverse Time (Thermal Magnetic or Electronic)	WB	CB	—	FD I3C	—	—	—	—	—	—	ND	—
High I.C. Inverse Time (Thermal Magnetic or Electronic)	—	CM	—	HFD I6C	HFD	HJD JD6D	HJD JD6D	HKD K6D	HLD	HMDL	HND	RD
Inverse Time (Thermal Magnetic) with Current Limiter	WD	CD	—	FDB-LFD I3C-CL	—	—	—	—	—	—	—	—
Extra High I.C. Inverse Time (Thermal Magnetic or Electronic)	—	CX	—	FDC I0C	—	—	JDC JD0D	KDC K0D	LDC	NDC	NDC	—

[1] Unit Series R only.

[2] 600A-2000A electronic trip circuit breakers.



# Vertical Sections and IntelliCENTER<sup>®</sup> Technology

Typical 15" Deep Section Construction

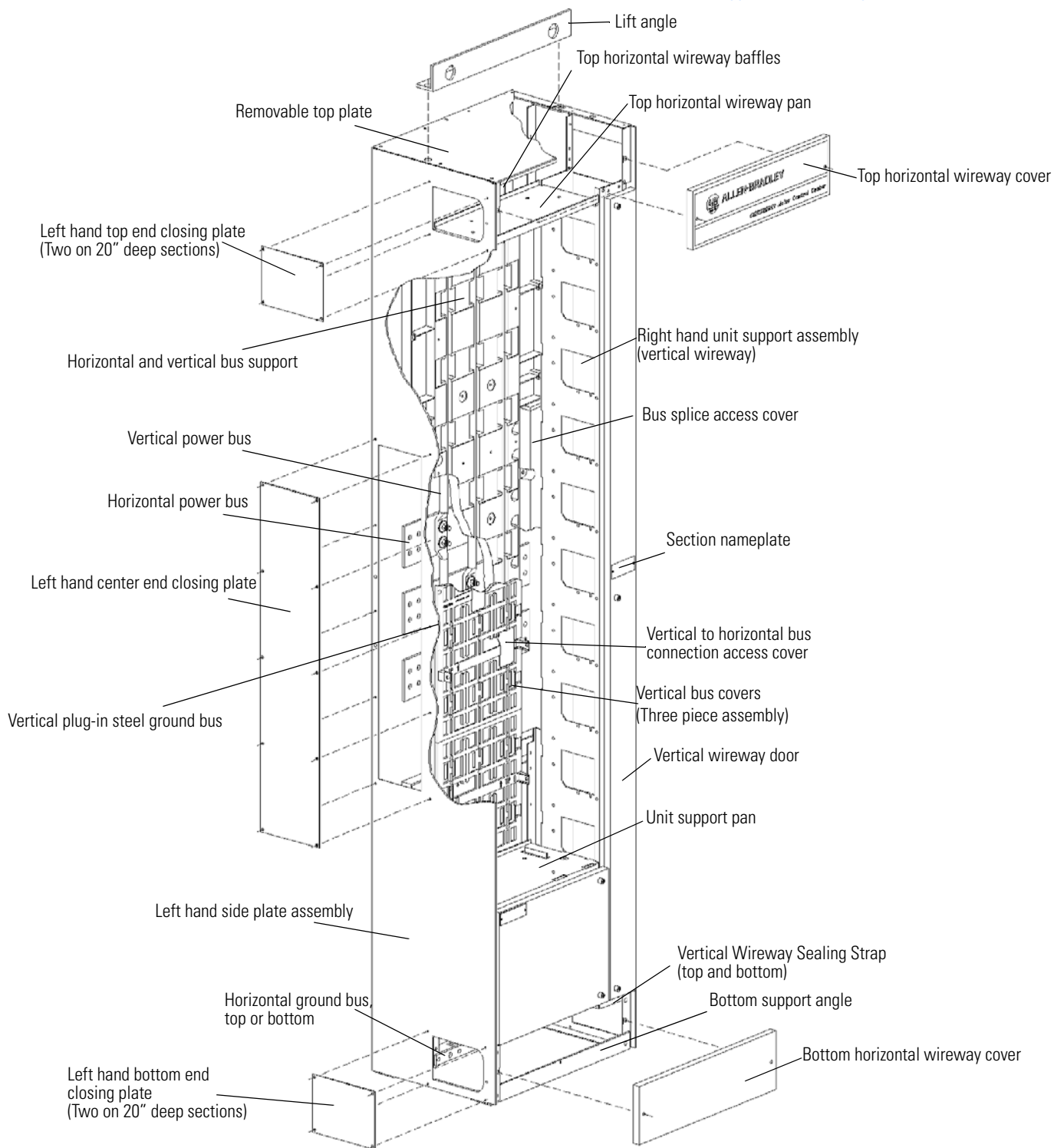

Catalog Number Explanation for Vertical Sections

2

- Maximum SC shipping block is three (3) vertical sections.
- End closing plates are supplied on each of the shipping blocks containing incoming line or main breaker sections.

9

Position								
First	Second	Third	Fourth	Fifth	Sixth	Seventh	Eighth	Ninth
2100	A	A	T	06	A	1	B	ABC - AAA - ANE
Bulletin Number	Bus Bar Bracing	Horizontal Bus Bar Material	Bus Bar Plating	Bus Bar Amperes	Section NEMA Type	Section Depth	Ground Bus	Section Location and Type

9A

Code	Type
2100	CENTERLINE Motor Control Center

9D

Code	Bus Bar Plating
T	Tin

9F

Code	Section NEMA Type
A	1
B	1 with gasket
J	12

9G

Code	Section Depth
1	15"
2	20"

9C

Code	Bus Bar Material
A [1]	Aluminum
B [1]	Aluminum with NO-OX-ID®
C	Copper
D	Copper with NO-OX-ID®

[1] Vertical bus will be supplied as Tin plated Copper

9B

Code	Bus Bar Bracing
A	42 kA Bus Bar Bracing
B	65 kA Bus Bar Bracing
C	42 kA Bus Bar Bracing with automatic shutters
D	65 kA Bus Bar Bracing with automatic shutters
E	42 kA Bus Bar Bracing with manual shutters
F	65 kA Bus Bar Bracing with manual shutters

9E

Code	Bus Bar Amperes
06	600
08	800
12	1200

9H

Code	Horizontal Ground Bus	Vertical Plug-In Ground Bus	Unit Load Ground Bus
B	Unplated copper 0.25" x 1"	Zinc plated steel 0.188" x 0.75"	-
C	Unplated copper 0.25" x 2"	Zinc plated steel 0.188" x 0.75"	-
D	Unplated copper 0.25" x 1"	Unplated copper 0.188" x 0.75"	-
E	Unplated copper 0.25" x 2"	Unplated copper 0.188" x 0.75"	-
F	Unplated copper 0.25" x 1"	Zinc plated steel 0.188" x 0.75"	Unplated copper 0.188" x 0.75"
G	Unplated copper 0.25" x 2"	Zinc plated steel 0.188" x 0.75"	Unplated copper 0.188" x 0.75"
H	Unplated copper 0.25" x 1"	Unplated copper 0.188" x 0.75"	Unplated copper 0.188" x 0.75"
K	Unplated copper 0.25" x 2"	Unplated copper 0.188" x 0.75"	Unplated copper 0.188" x 0.75"
N	Tin plated copper 0.25" x 1"	Tin plated copper 0.188" x 0.75"	-
P	Tin plated copper 0.25" x 2"	Tin plated copper 0.188" x 0.75"	-
S	Tin plated copper 0.25" x 1"	Tin plated copper 0.188" x 0.75"	Tin plated copper 0.188" x 0.75"
T	Tin plated copper 0.25" x 2"	Tin plated copper 0.188" x 0.75"	Tin plated copper 0.188" x 0.75"

See page 13 for description of Ninth Position

## Vertical Sections and IntelliCENTER® Technology Catalog Number Explanation for Vertical Sections (SC)

- The **NINTH POSITION** consists of three (3) groups of three (3) letters each.
- Each group of three (3) letters represents one (1) section. Select one (1) letter from each column to specify one (1) section.
  - Separate each section with a dash (e.g., 2100-AAT06-A1B-**ABC-AAA-ANE**).
  - If only one (1) section is selected, only one (1) group of three (3) letters is needed.
  - If two (2) sections are selected, two (2) groups of three (3) letters are needed, separated by a dash.
  - If three (3) sections are selected, three (3) groups of three (3) letters are needed, with each group of letters separated by a dash..

continued from page 12

		Position						
		Ninth						
		- <b>ABC</b> - <b>AAA</b> - <b>ANE</b>						
		Section Location and Type						
				10				
A	20" Wide Section	A Standard Section	A	For plug-in units				
A	20" Wide Section	Z 6.0 Space Factor, Full mounting plate, 8.5" working depth, without vertical bus and without vertical wireway	X	No plug-in units				
A	20" Wide Section	B Incoming Line Lugs - Top C Incoming Line Lugs - Bottom	J	300A, 1.0 Space Factor				
			A	600A, 1.0 Space Factor				
			B	600A, 1.5 Space Factor				
			C	600A, Top - in horizontal wireway with pullbox				
			D	800A, 1.5 Space Factor				
			E	800A, 2.0 Space Factor				
			F	800A, Top, 1.0 Space Factor with pullbox				
			G	1200A, 2.0 Space Factor				
			H	1200A, Top - 1.0 Space Factor with pullbox				
			A	20" Wide Section	D Main FDS - Top, 600V E Main FDS - Bottom, 600V F Feeder FDS - Top, 600V G Feeder FDS - Bottom, 600V	A	200A, R-Clips (Available as main only)	
B	200A, J-Clips (Available as main only)							
C	400A, R-Clips							
D	400A, J-Clips							
E	600A, R-Clips							
F	600A, J-Clips							
G	600A, Non-fused (Available as main only)							
H	800A, L-Clips							
J	800A, Non-fused (Available as main only)							
K	1200A, L-Clips							
A	20" Wide Section	H Main Circuit Breaker - Top J Main Circuit Breaker - Bottom K Feeder Circuit Breaker - Top L Feeder Circuit Breaker - Bottom See Appendix for circuit breaker interrupting capacity	L	1200A, Non-fused (Available as main only)				
			A	225A, JD3D (Available as main only)				
			B	225A, JD6D (Available as main only)				
			C	225A, JD0D (Available as main only)				
			D	400A, K3D				
			E	400A, K6D				
			F	400A, K0D				
			G	600A, LD				
			H	600A, HLD				
			J	600A, LDC				
A	20" Wide Section	M Transformer - 480V Primary N Transformer - 600V Primary	K	800A, MDL				
			L	800A, MDLG (Available as main only)				
			M	800A, HMDL				
			N	800A, HMDLG (Available as main only)				
			P	1200A, ND				
			Q	1200A, HND				
			R	1200A, NDG (Available as main only)				
			S	1200A, HNDG (Available as main only)				
			A	20" Wide Section	M Transformer - 480V Primary N Transformer - 600V Primary	Single Phase, Bottom Mounted	A	3 kVA (1.5 kVA) <sup>[2],[3]</sup> , 120V Sec.
							B	5 kVA (2.5 kVA) <sup>[2],[3]</sup> , 120/240V Sec.
C	7.5 kVA (3.7 kVA) <sup>[2],[3]</sup> , 120/240V Sec.							
Three Phase, Bottom Mounted	D	10 kVA (5 kVA) <sup>[2],[3]</sup> , 120/240V Sec.						
	E	15 kVA (7.5 kVA) <sup>[2],[3]</sup> , 120/240V Sec.						
	F	25 kVA (12.5 kVA) <sup>[2],[3]</sup> , 120/240V Sec.						
A	25" Wide Section with 9" vertical wireway <sup>[1]</sup>	A Standard Section	J	10 kVA (5 kVA) <sup>[2],[3]</sup> , 120/208V Sec.				
			K	15 kVA (7.5 kVA) <sup>[2],[3]</sup> , 120/208V Sec.				
			L	25 kVA (12.5 kVA) <sup>[2],[3]</sup> , 120/208V Sec.				
7	Corner Section (supplied as a single shipping block only)	X No Modifications	M	30 kVA (15 kVA) <sup>[2],[3]</sup> , 120/208V Sec.				
			X	No Modifications				

[1] Shipping block maximum is two (2) sections. Cannot ship 20" and 25" wide sections in the same shipping block.  
 [2] For NEMA Type 1 and NEMA Type 1 with gasket applications 3kVA and larger, a vented door is provided.  
 [3] In NEMA Type 12 applications (non-ventilated 3kVA and larger transformers), to maximize the transformer's life, it is recommended that the transformer not be loaded greater than 50% of its nameplate rating.

Catalog Number Explanation for Vertical Sections (SC)

2

- Maximum SC shipping block is three (3) vertical sections.
- End closing plates are supplied on each of the shipping blocks containing incoming line or main breaker sections.

11

POSITION Description	Catalog Number Character	Description	Delivery Program	
SECOND Bus Bar Bracing	A	42kA bus bar bracing	SC	
	B	65kA bus bar bracing		
	C	42kA bus bar bracing with automatic shutters		
	D	65kA bus bar bracing with automatic shutters		
	E	42kA bus bar bracing with manual shutters		
	F	65kA bus bar bracing with manual shutters		
THIRD, FOURTH and FIFTH Bus Bar Material and Plating	AT06	600A aluminum bus with tin plating <sup>[1]</sup>		
	BT06	600A aluminum bus with tin plating and NO-OX-ID <sup>[1]</sup>		
	CT06	600A copper bus with tin plating		
	CT08	800A copper bus with tin plating		
	CT12	1200A copper bus with tin plating		
	DT06	600A copper bus with tin plating and NO-OX-ID		
	DT08	800A copper bus with tin plating and NO-OX-ID		
	DT12	1200A copper bus with tin plating and NO-OX-ID		
SIXTH NEMA Enclosure Type	A	NEMA Type 1		
	B	NEMA Type 1 with gasket		
	J	NEMA Type 12		
SEVENTH Section Depth	1	15" cabinet depth		
	2	20" cabinet depth		
EIGHTH Ground Bus  (Horizontal ground bus is mounted at the bottom of vertical section.)	B	Unplated copper horizontal ground bus and vertical plug-in steel ground bus		0.25" × 1"
	C			0.25" × 2"
	D	Unplated copper horizontal ground bus and vertical plug-in unplated copper ground bus		0.25" × 1"
	E			0.25" × 2"
	F	Unplated copper horizontal ground bus, unit load ground bus and vertical plug-in steel ground bus. If required, select unit load ground connectors on plug-in units. See page 116.		0.25" × 1"
	G		0.25" × 2"	
	H	Unplated copper horizontal ground bus, unit load ground bus and vertical plug-in unplated copper ground bus. If required, select unit load ground connectors on plug-in units. See page 116.	0.25" × 1"	
	K		0.25" × 2"	
	N	Tin plated copper horizontal ground bus and vertical plug-in tin plated copper ground bus. Select tin-plated unit ground stabs on all plug-in units. See page 116.	0.25" × 1"	
	P		0.25" × 2"	
	S	Tin plated copper horizontal ground bus, tin plated copper unit load ground bus and vertical plug-in tin plated copper ground bus. Select tin plated unit ground stabs on all plug-in units. See page 116. If required, select unit load ground connectors on plug-in units. See page 116.	0.25" × 1"	
	T		0.25" × 2"	

NINTH POSITION (On next page)

[1] Vertical bus will be supplied as Tin plated copper

Catalog Number Explanation for Vertical Sections (SC)

- Maximum SC shipping block is three (3) vertical sections.
- *End closing plates* are supplied on each of the shipping blocks containing incoming line or main breaker sections.

POSITION		Catalog Number Character		Description				Space Factors Used	Delivery Program
Description									
NINTH Section Location and Type	Basic Section	AAA		20" wide section, for plug-in units				6.0	SC
		AZX Supplied as a single section block only.		20" wide section, full mounting plate, 8.5" working depth, with horizontal bus, no vertical bus and no vertical wireway					
		BAA		25" wide section with 9" wireway, for plug-in units. Maximum shipping block is two sections.					
	Incoming Line Section  AB_ (top entry) or AC_ (bottom entry)  See page 215 for optional lug selections.	Top Entry	Bottom Entry						
		ABJ	ACJ	300A				1.0	
		ABA	ACA	600A				1.0	
		ABB	ACB	600A				1.5	
		ABC	—	600A—Top entry with 12" pullbox with lug pad in horizontal wireway (pullbox shipped separately)				0.0	
		ABD	ACD	800A				1.5	
		ABE	ACE	800A				2.0	
		ABF	—	800A—Top entry with 12" pullbox (pullbox shipped separately)				1.0	
		ABG	ACG	1200A				2.0	
		ABH	—	1200A—Top entry with 12" pullbox (pullbox shipped separately)				1.0	
	Main Fusible Disconnect Section 600V  AD_ (top entry) or AE_ (bottom entry) See page 70 for short circuit withstand ratings.	ADA	AEA	200A	R-Clips	#6-4/0 AWG, 1/phase	CU	2.0	
		ADB	AEB	200A	J-Clips	#6-4/0 AWG, 1/phase	CU	2.0	
		ADC	AEC	400A	R-Clips	#1/0-250 kcmil, 2/phase	CU	2.5	
		ADD	AED	400A	J-Clips	#1/0-250 kcmil, 2/phase	CU	2.5	
		ADE	AEE	600A	R-Clips	#2-600 kcmil, 2/phase	CU/AL	3.5	
		ADF	AEF	600A	J-Clips	#2-600 kcmil, 2/phase	CU/AL	3.5	
		ADG	AEG	600A	Non-fused	#2-600 kcmil, 2/phase	CU/AL	3.5	
		ADH	AEH	800A	L-Clips	#6-350 kcmil, 3/phase	CU/AL	3.5	
		ADJ	AEJ	800A	Non-fused	#6-350 kcmil, 3/phase	CU/AL	3.5	
		ADK	AEK	1200A	L-Clips	#6-350 kcmil, 3/phase	CU/AL	3.5	
ADL	AEL	1200A	Non-fused	#6-350 kcmil, 3/phase	CU/AL	3.5			
Feeder Fusible Disconnect Section 600V  AF_ (top entry) or AG_ (bottom entry) See page 70 for short circuit withstand ratings.	AFC	AGC	400A	R-Clips	#1/0-250 kcmil, 2/phase	CU	2.5		
	AFD	AGD	400A	J-Clips	#1/0-250 kcmil, 2/phase	CU	2.5		
	AFE	AGE	600A	R-Clips	#2-600 kcmil, 2/phase	CU/AL	3.5		
	AFF	AGF	600A	J-Clips	#2-600 kcmil, 2/phase	CU/AL	3.5		
	AFH	AGH	800A	L-Clips	#6-350 kcmil, 3/phase	CU/AL	3.5		
	AFK	AGK	1200A	L-Clips	#6-350 kcmil, 3/phase	CU/AL	3.5		

NINTH POSITION (Continued on next page)

Catalog Number Explanation for Vertical Sections (SC)

2

- Maximum SC shipping block is three (3) vertical sections.
  - End closing plates are supplied on each of the shipping blocks containing incoming line or main breaker sections.
- Ninth position—continued from previous page.

13

POSITION Description	Catalog Number Character		Description					Space Factors Used	Delivery Program
	Top Entry	Bottom Entry							
NINTH  Section Location and Type	Main Circuit Breaker Section  AH_ (top entry) or AJ_ (bottom entry)  See page 236 for circuit breaker interrupting capacity	AHA	AJA	225A	JD3D	#4-350 kcmil, 1/phase	CU	1.5	SC
		AHB	AJB	225A	JD6D	#4-350 kcmil, 1/phase	CU	1.5	
		AHC	AJC	225A	JD0D	#4-350 kcmil, 1/phase	CU	1.5	
		AHD	AJD	400A	K3D	#3/0-250 kcmil, 2/phase	CU	2.0	
		AHE	AJE	400A	K6D	#3/0-250 kcmil, 2/phase	CU	2.0	
		AHF	AJF	400A	K0D	#3/0-250 kcmil, 2/phase	CU	2.0	
		AHG	AJG	600A	LD	250-350 kcmil, 2/phase	CU	2.0	
		AHH	AJH	600A	HLD	250-350 kcmil, 2/phase	CU	2.0	
		AHJ	AJJ	600A	LDC	250-350 kcmil, 2/phase	CU	2.0	
		AHK	AJK	800A	MDL	#3/0-300 kcmil, 3/phase	CU	2.5	
	AHL	AJL	800A	MDLG	#3/0-300 kcmil, 3/phase, with ground fault	CU	2.5		
	AHM	AJM	800A	HMDL	#3/0-300 kcmil, 3/phase	CU	2.5		
	AHN	AJN	800A	HMDLG	#3/0-300 kcmil, 3/phase, with ground fault	CU	2.5		
	AHP	AJP	1200A	ND	#4/0-400 kcmil, 4/phase	CU	3.5		
	AHQ	AJQ	1200A	HND	#4/0-400 kcmil, 4/phase	CU	3.5		
	AHR	AJR	1200A	NDG	#4/0-400 kcmil, 4/phase, with ground fault	CU	3.5		
	AHS	AJS	1200A	HNDG	#4/0-400 kcmil, 4/phase, with ground fault	CU	3.5		
	Feeder Circuit Breaker Section  AK_ (top entry) or AL_ (bottom entry)  See page 236 for circuit breaker interrupting capacity	AKD	ALD	400A	K3D	#3/0-250 kcmil, 2/phase	CU	2.0	
		AKE	ALE	400A	K6D	#3/0-250 kcmil, 2/phase	CU	2.0	
		AKF	ALF	400A	K0D	#3/0-250 kcmil, 2/phase	CU	2.0	
AKG		ALG	600A	LD	250-350 kcmil, 2/phase	CU	2.0		
AKH		ALH	600A	HLD	250-350 kcmil, 2/phase	CU	2.0		
AKJ		ALJ	600A	LDC	250-350 kcmil, 2/phase	CU	2.0		
AKK		ALK	800A	MDL	#3/0-300 kcmil, 3/phase	CU	2.5		
AKM		ALM	800A	HMDL	#3/0-300 kcmil, 3/phase	CU	2.5		
AKP	ALP	1200A	ND	#4/0-400 kcmil, 4/phase	CU	3.5			
AKQ	ALQ	1200A	HND	#4/0-400 kcmil, 4/phase	CU	3.5			

NINTH POSITION  
(Continued on next page)

Catalog Number Explanation for Vertical Sections (SC)

- Maximum SC shipping block is three (3) vertical sections.
  - *End closing plates* are supplied on each of the shipping blocks containing incoming line or main breaker sections.
- Ninth position—continued from previous page

Position Description		Catalog Number Character		Description	Space Factors Used	Delivery Program	
		480V Primary	600V Primary				
NINTH Section Location and Type	Transformer Section <sup>[1],[2]</sup>  AM_ (480V PRIMARY) or AN_ (600V PRIMARY)	AMA	ANA	Single Phase Bottom Mounted	3kVA (1.5kVA), 120V sec. without tap (secondary fused to 120V)	1.5	SC
		AMB	—		5kVA (2.5kVA), 120/240V sec. without tap (secondary fused to 240V)	1.5	
		AMC	ANC		7.5kVA (3.7kVA), 120/240V sec. without tap (secondary fused to 240V)	1.5	
		AMD	AND		10kVA (5kVA), 120/240V sec. without tap (secondary fused to 240V)	1.5	
		AME	ANE		15kVA (7.5kVA), 120/240 sec. with (2) 2.5% taps FCAN, (4) 2.5% taps FCBN (secondary fused for 240V)	2.0	
		AMF	ANF	25kVA (12.5kVA), 120/240 sec. with (2) 2.5% taps FCAN, (4) 2.5% taps FCBN (secondary fused for 240V)	2.0		
		AMJ	ANJ	Three Phase Bottom Mounted	10kVA (5kVA), 120/208V sec. with (2) 2.5% taps FCAN, (2) 2.5% taps FCBN (secondary fused to 208V)	1.5	
		AMK	ANK		15kVA (7.5kVA), 120/208V sec. with (2) 2.5% taps FCAN, (2) 2.5% taps FCBN (secondary fused to 208V)	2.0	
		AML	ANL		25kVA (12.5kVA), 120/208V sec. with (2) 2.5% taps FCAN, (2) 2.5% taps FCBN (secondary fused to 208V)	2.0	
	AMM	ANM	30kVA (15kVA), 120/208V sec. with (2) 2.5% taps FCAN, (2) 2.5% taps FCBN (secondary fused to 208V)		2.0		
Corner Section	<b>7XX</b>		Single section shipping split only. 15" or 20" deep enclosure without lugs. See page 223 for dimensions.		6.0		

[1] For NEMA Type 1 and NEMA Type 1 with gasket applications, a vented door is provided.

[2] In NEMA Type 12 applications (non-ventilated 3kVA and larger transformers), to maximize the transformer's life, it is recommended that the transformer not be loaded to greater than 50% of its nameplate rating.

Vertical Sections (SC) (Without Vertical Wireway)

2

- Maximum SC shipping block is one (1) vertical section.
- End closing plates are supplied.
- Splice kits are *not included*.
- Enclosures without horizontal bus are UL listed under the UL Standard for Safety UL 508 unless otherwise indicated.

15

Description	Working Depth (Inches)	Section		NEMA Type 1	NEMA Type 12	Delivery Program
		Depth (Inches)	Width (Inches)	Catalog Number	Catalog Number	
Vertical Section  Includes full six (6.0) space factor door and mounting plate. No vertical wireway.	8.5 (with horizontal bus)	15	20	2100-EKC1_1D-__ <sup>[1]</sup>	2100-EJC1_1D-__ <sup>[1]</sup>	SC
			25	2100-EKC1_2D-__ <sup>[1]</sup>	2100-EJC1_2D-__ <sup>[1]</sup>	
			30	2100-EKC1_3D-__ <sup>[1]</sup>	2100-EJC1_3D-__ <sup>[1]</sup>	
			35	2100-EKC1_4D-__ <sup>[1]</sup>	2100-EJC1_4D-__ <sup>[1]</sup>	
		20	20	2100-EKC2_1D-__ <sup>[1]</sup>	2100-EJC2_1D-__ <sup>[1]</sup>	
			25	2100-EKC2_2D-__ <sup>[1]</sup>	2100-EJC2_2D-__ <sup>[1]</sup>	
			30	2100-EKC2_3D-__ <sup>[1]</sup>	2100-EJC2_3D-__ <sup>[1]</sup>	
			35	2100-EKC2_4D-__ <sup>[1]</sup>	2100-EJC2_4D-__ <sup>[1]</sup>	
	11.5 (with horizontal bus) <sup>[2]</sup>	20	20	2100-EKC2_1A-__ <sup>[1]</sup>	2100-EJC2_1A-__ <sup>[1]</sup>	
			25	2100-EKC2_2A-__ <sup>[1]</sup>	2100-EJC2_2A-__ <sup>[1]</sup>	
			30	2100-EKC2_3A-__ <sup>[1]</sup>	2100-EJC2_3A-__ <sup>[1]</sup>	
			35	2100-EKC2_4A-__ <sup>[1]</sup>	2100-EJC2_4A-__ <sup>[1]</sup>	
	14 (with horizontal bus) <sup>[2]</sup>	20	20	2100-EKC2_1B-__ <sup>[1]</sup>	2100-EJC2_1B-__ <sup>[1]</sup>	
			25	2100-EKC2_2B-__ <sup>[1]</sup>	2100-EJC2_2B-__ <sup>[1]</sup>	
			30	2100-EKC2_3B-__ <sup>[1]</sup>	2100-EJC2_3B-__ <sup>[1]</sup>	
			35	2100-EKC2_4B-__ <sup>[1]</sup>	2100-EJC2_4B-__ <sup>[1]</sup>	
	11.5 (without horizontal bus)	15	20	2100-EKC1_1A <sup>[3]</sup>	2100-EJC1_1A <sup>[3]</sup>	
			25	2100-EKC1_2A <sup>[3]</sup>	2100-EJC1_2A <sup>[3]</sup>	
			30	2100-EKC1_3A <sup>[3]</sup>	2100-EJC1_3A <sup>[3]</sup>	
			35	2100-EKC1_4A <sup>[3]</sup>	2100-EJC1_4A <sup>[3]</sup>	
			40 <sup>[4]</sup>	2100-EKC1_5A <sup>[3]</sup>	2100-EJC1_5A <sup>[3]</sup>	
	14 (without horizontal bus)	15	20	2100-EKC1_1B <sup>[3]</sup>	2100-EJC1_1B <sup>[3]</sup>	
			25	2100-EKC1_2B <sup>[3]</sup>	2100-EJC1_2B <sup>[3]</sup>	
			30	2100-EKC1_3B <sup>[3]</sup>	2100-EJC1_3B <sup>[3]</sup>	
			35	2100-EKC1_4B <sup>[3]</sup>	2100-EJC1_4B <sup>[3]</sup>	
			40 <sup>[4]</sup>	2100-EKC1_5B <sup>[3]</sup>	2100-EJC1_5B <sup>[3]</sup>	
	19 (without horizontal bus)	20	20	2100-EKC2_1C <sup>[3]</sup>	2100-EJC2_1C <sup>[3]</sup>	
			25	2100-EKC2_2C <sup>[3]</sup>	2100-EJC2_2C <sup>[3]</sup>	
30			2100-EKC2_3C <sup>[3]</sup>	2100-EJC2_3C <sup>[3]</sup>		
35			2100-EKC2_4C <sup>[3]</sup>	2100-EJC2_4C <sup>[3]</sup>		
40 <sup>[4]</sup>			2100-EKC2_5C <sup>[3]</sup>	2100-EJC2_5C <sup>[3]</sup>		

[1] The catalog numbers listed are not complete:  
 • Select ground bus option B, C, N, or D from table on 14 (only horizontal ground bus is supplied; e.g., 2100-EKC1**B**).  
 • Select bus bar bracing, A or B, from table on 14 (horizontal bus is provided in vertical section; e.g., 2100-EKC1B1D-**A**).  
 • Select bus bar material and plating from table on 14 (e.g., 2100-EKC1B1D-**AAT06**).

[2] Horizontal bus is 5" deeper than standard.

[3] The catalog numbers listed are not complete. Select ground bus option B, C, N, or P from table on 14 (only horizontal ground bus is supplied; e.g., 2100-EKC1**B**1A).

[4] 40" wide vertical section is a two-door section with a 3-point latch.

Vertical Sections With Fusible Disconnect (SC) (Without Vertical Wireway)

- Maximum SC shipping block is one (1) vertical section.
- End closing plates are supplied.
- Splice kits are *not included*.
- Line side of disconnect is connected to horizontal bus for sections with horizontal bus.

16

Description	Working Depth (Inches)	Section		Disconnect Rating (Amperes) [1]	NEMA Type 1	NEMA Type 12	Delivery Program
		Depth (Inches)	Width (Inches)		Catalog Number [2]	Catalog Number [2]	
Vertical Section  Includes full six (6.0) space factor door and mounting plate. With disconnecting means. No vertical wireway. See page 75 for short circuit withstand ratings. Adding equipment to these sections may void UL and C-UL/CSA certification.	8.5 (with horizontal bus)	15	20	30, 60	2100-FK_1_1D-_-_-	2100-FJ_1_1D-_-_-	SC
				100			
				200			
				400			
			25	30,60	2100-FK_1_2D-_-_-	2100-FJ_1_2D-_-_-	
				100			
				200			
				400			
			30	30, 60	2100-FK_1_3D-_-_-	2100-FJ_1_3D-_-_-	
				100			
				200			
				400			
		35	30, 60	2100-FK_1_4D-_-_-	2100-FJ_1_4D-_-_-		
			100				
			200				
			400				
		20	20	30, 60	2100-FK_2_1D-_-_-	2100-FJ_2_1D-_-_-	
				100			
				200			
				400			
			25	30, 60	2100-FK_2_2D-_-_-	2100-FJ_2_2D-_-_-	
				100			
				200			
				400			
30	30, 60		2100-FK_2_3D-_-_-	2100-FJ_2_3D-_-_-			
	100						
	200						
	400						
35	30, 60	2100-FK_2_4D-_-_-	2100-FJ_2_4D-_-_-				
	100						
	200						
	400						

[1] Disconnect rating must match fuse clip size. Oversizing or undersizing of fuse clips is not permitted.  
 [2] The catalog numbers listed are not complete:  
 • Select voltage code from page 23 (e.g., 2100-FK**C**).  
 • Select ground bus option B, C, N, or P from table on 14 (only horizontal ground bus is supplied; e.g., 2100-FK**C1B**).  
 • Select bus bar bracing, A or B, from table on 14 (horizontal bus is provided in vertical section; e.g., 2100-FK**C1B1D-A**).  
 • Select bus bar material and plating from table on 14 (e.g., 2100-FK**C1B1D-AAT06**).  
 • Select fuse clip designator from page 23 (e.g., 2100-FK**C1B1D-AAT06-24J**).

Vertical Sections With Fusible Disconnect (SC) (Without Vertical Wireway)

2

- Maximum SC shipping block is one (1) vertical section.
- End closing plates are supplied.
- Splice kits are not included.
- Enclosures without horizontal bus are UL listed to the UL Standard for Safety UL 508 unless otherwise indicated, short circuit withstand rating marking do *not* apply.
- Line side of disconnect is connected to horizontal bus for sections with horizontal bus.
- Customer cables connect to line side of disconnect for sections without horizontal bus.

17

Description	Working Depth (Inches)	Section		Disconnect Rating (Amperes) [1]	NEMA Type 1	NEMA Type 12	Delivery Program		
		Depth (Inches)	Width (Inches)		Catalog Number	Catalog Number			
Vertical Section  Includes full six (6.0) space factor door and mounting plate. With disconnecting means. No vertical wireway. See page 75 for short circuit withstand ratings. Adding equipment to these sections may void UL and C-UL/CSA certification.	11.5 (with horizontal bus) [2]	20	20	30, 60	2100-FK_2_1A-_-_- [3]	2100-FJ_2_1A-_-_- [3]	SC		
				100					
				200					
				400					
			14 (with horizontal bus) [2]	20	25	30, 60		2100-FK_2_2A-_-_- [3]	2100-FJ_2_2A-_-_- [3]
						100			
						200			
						400			
					30	30, 60		2100-FK_2_3A-_-_- [3]	2100-FJ_2_3A-_-_- [3]
						100			
						200			
						400			
	35	30, 60			2100-FK_2_4A-_-_- [3]	2100-FJ_2_4A-_-_- [3]			
		100							
		200							
		400							
	11.5 (without horizontal bus)	15	20	30, 60	2100-FK_1_1A-_- [4]	2100-FJ_1_1A-_- [4]			
				100					
				200					
				400					
			25	30, 60	2100-FK_1_2A-_- [4]	2100-FJ_1_2A-_- [4]			
				100					
				200					
				400					
			30	30, 60	2100-FK_1_3A-_- [4]	2100-FJ_1_3A-_- [4]			
				100					
				200					
				400					
35	30, 60	2100-FK_1_4A-_- [4]	2100-FJ_1_4A-_- [4]						
	100								
	200								
	400								

[1] Disconnect rating must match fuse clip size. Oversizing or undersizing of fuse clips is not permitted.  
 [2] Horizontal bus is 5" deeper than standard.  
 [3] The catalog numbers listed are not complete:  
 • Select voltage code on page 23 (e.g., 2100-FK**C**).  
 • Select ground bus option B, C, N, or P from table on 14 (only horizontal ground bus is supplied; e.g. 2100-FK**C2B**).  
 • Select bus bar bracing, A or B, from table on 14 (horizontal bus is provided in vertical section; e.g., 2100-FK**C2B1B-A**).  
 • Select bus bar material and plating from table on 14 (e.g., 2100-FK**C2B1B-AAT06**).  
 • Select fuse clip designator on page 23 (e.g., 2100-FK**C2B1A-AAT06-24J**).  
 [4] The catalog numbers listed are not complete:  
 • Select voltage code on page 23 (e.g., 2100-FK**C**).  
 • Select ground bus option B, C, N, or P from table on 14 (only horizontal ground bus is supplied; e.g., 2100-FK**C1B**).  
 • Select fuse clip designator from on page 23 (e.g., 2100-FK**C1B1A-24J**).

Vertical Sections With Fusible Disconnect (SC) (Without Vertical Wireway)

- Maximum SC shipping block is one (1) vertical section.
- *End closing plates* are supplied.
- Enclosures without horizontal bus are UL listed to the UL Standard for Safety UL 508 unless otherwise indicated, short circuit withstand rating marking does *not* apply.
- Line side of disconnect is connected to horizontal bus for sections with horizontal bus.
- Customer cables connect to line side of disconnect for sections without horizontal bus.

18

Description	Working Depth (Inches)	Section		Disconnect Rating (Amperes) <sup>[1]</sup>	NEMA Type 1	NEMA Type 12	Delivery Program
		Depth (Inches)	Width (Inches)		Catalog Number	Catalog Number	
Vertical Section  Includes full six (6.0) space factor door and mounting plate. With disconnecting means. No vertical wireway.  Adding equipment to these sections may void UL and C-UL/CSA certification.	11.5 (without horizontal bus)	20	20	30, 60	2100-FK_2_1A- <sup>[2]</sup>	2100-FJ_2_1A- <sup>[2]</sup>	SC
				100			
				200			
				400			
			25	30, 60	2100-FK_2_2A- <sup>[2]</sup>	2100-FJ_2_2A- <sup>[2]</sup>	
				100			
				200			
				400			
			30	30, 60	2100-FK_2_3A- <sup>[2]</sup>	2100-FJ_2_3A- <sup>[2]</sup>	
				100			
				200			
				400			
	35	30, 60	2100-FK_2_4A- <sup>[2]</sup>	2100-FJ_2_4A- <sup>[2]</sup>			
		100					
		200					
		400					
	14 (without horizontal bus)	15	20	30, 60	2100-FK_1_1B- <sup>[2]</sup>	2100-FJ_1_1B- <sup>[2]</sup>	
				100			
				200			
				400			
			25	30, 60	2100-FK_1_2B- <sup>[2]</sup>	2100-FJ_1_2B- <sup>[2]</sup>	
				100			
				200			
				400			
30			30, 60	2100-FK_1_3B- <sup>[2]</sup>	2100-FJ_1_3B- <sup>[2]</sup>		
			100				
			200				
			400				
35	30, 60	2100-FK_1_4B- <sup>[2]</sup>	2100-FJ_1_4B- <sup>[2]</sup>				
	100						
	200						
	400						
19 (without horizontal bus)	20	20	30, 60	2100-FK_2_1C- <sup>[2]</sup>	2100-FJ_2_1C- <sup>[2]</sup>		
			100				
			200				
			400				
		25	30, 60	2100-FK_2_2C- <sup>[2]</sup>	2100-FJ_2_2C- <sup>[2]</sup>		
			100				
			200				
			400				
		30	30, 60	2100-FK_2_3C- <sup>[2]</sup>	2100-FJ_2_3C- <sup>[2]</sup>		
			100				
			200				
			400				
35	30, 60	2100-FK_2_4C- <sup>[2]</sup>	2100-FJ_2_4C- <sup>[2]</sup>				
	100						
	200						
	400						

[1] Disconnect rating must match fuse clip size. Oversizing or undersizing of fuse clips is not permitted.

[2] The catalog numbers listed are not complete:

- Select voltage code from on page 23 (e.g., 2100-FK**C**).
- Select ground bus option B, C, N, or P from 14 (only horizontal ground bus is supplied; e.g., 2100-FK**C1B**).
- Select fuse clip designator from on page 23 (e.g., 2100-FK**C1B1B-24J**).

Vertical Sections With Circuit Breaker (SC) (Without Vertical Wireway)

2

- Maximum SC shipping block is one (1) vertical section.
- End closing plates are supplied.
- Splice kits are not included.
- Enclosures without horizontal bus are UL listed to the UL Standard for Safety UL 508 unless otherwise indicated, short circuit interrupting capacity marking does *not* apply.
- Line side of circuit breaker is connected to horizontal bus for sections with horizontal bus.
- Customer cables connect to line side of circuit breaker for sections without horizontal bus.

19

Description	Working Depth (Inches)	Section		NEMA Type 1	NEMA Type 12	Delivery Program
		Depth (Inches)	Width (Inches)	Catalog Number	Catalog Number	
Vertical Section  Includes full six (6.0) space factor door and mounting plate. With disconnecting means. No vertical wireway. See page 236 for circuit breaker interrupting capacity. Adding equipment to these sections may void UL and C-UL/CSA certification.	8.5 (with horizontal bus)	15	20	2100-GKC1_1D-__-__ <sup>[1]</sup>	2100-GJC1_1D-__-__ <sup>[1]</sup>	SC
			25	2100-GKC1_2D-__-__ <sup>[1]</sup>	2100-GJC1_2D-__-__ <sup>[1]</sup>	
			30	2100-GKC1_3D-__-__ <sup>[1]</sup>	2100-GJC1_3D-__-__ <sup>[1]</sup>	
			35	2100-GKC1_4D-__-__ <sup>[1]</sup>	2100-GJC1_4D-__-__ <sup>[1]</sup>	
		20	20	2100-GKC2_1D-__-__ <sup>[1]</sup>	2100-GJC2_1D-__-__ <sup>[1]</sup>	
			25	2100-GKC2_2D-__-__ <sup>[1]</sup>	2100-GJC2_2D-__-__ <sup>[1]</sup>	
			30	2100-GKC2_3D-__-__ <sup>[1]</sup>	2100-GJC2_3D-__-__ <sup>[1]</sup>	
			35	2100-GKC2_4D-__-__ <sup>[1]</sup>	2100-GJC2_4D-__-__ <sup>[1]</sup>	
	11.5 (with horizontal bus) <sup>[2]</sup>	20	20	2100-GKC2_1A-__-__ <sup>[1]</sup>	2100-GJC2_1A-__-__ <sup>[1]</sup>	
			25	2100-GKC2_2A-__-__ <sup>[1]</sup>	2100-GJC2_2A-__-__ <sup>[1]</sup>	
			30	2100-GKC2_3A-__-__ <sup>[1]</sup>	2100-GJC2_3A-__-__ <sup>[1]</sup>	
			35	2100-GKC2_4A-__-__ <sup>[1]</sup>	2100-GJC2_4A-__-__ <sup>[1]</sup>	
	14 (with horizontal bus) <sup>[2]</sup>	20	20	2100-GKC2_1B-__-__ <sup>[1]</sup>	2100-GJC2_1B-__-__ <sup>[1]</sup>	
			25	2100-GKC2_2B-__-__ <sup>[1]</sup>	2100-GJC2_2B-__-__ <sup>[1]</sup>	
			30	2100-GKC2_3B-__-__ <sup>[1]</sup>	2100-GJC2_3B-__-__ <sup>[1]</sup>	
			35	2100-GKC2_4B-__-__ <sup>[1]</sup>	2100-GJC2_4B-__-__ <sup>[1]</sup>	
	11.5 (without horizontal bus)	15	20	2100-GKC1_1A-__-__ <sup>[3]</sup>	2100-GJC1_1A-__-__ <sup>[3]</sup>	
			25	2100-GKC1_2A-__-__ <sup>[3]</sup>	2100-GJC1_2A-__-__ <sup>[3]</sup>	
			30	2100-GKC1_3A-__-__ <sup>[3]</sup>	2100-GJC1_3A-__-__ <sup>[3]</sup>	
			35	2100-GKC1_4A-__-__ <sup>[3]</sup>	2100-GJC1_4A-__-__ <sup>[3]</sup>	
		20	20	2100-GKC2_1A-__-__ <sup>[3]</sup>	2100-GJC2_1A-__-__ <sup>[3]</sup>	
			25	2100-GKC2_2A-__-__ <sup>[3]</sup>	2100-GJC2_2A-__-__ <sup>[3]</sup>	
			30	2100-GKC2_3A-__-__ <sup>[3]</sup>	2100-GJC2_3A-__-__ <sup>[3]</sup>	
			35	2100-GKC2_4A-__-__ <sup>[3]</sup>	2100-GJC2_4A-__-__ <sup>[3]</sup>	
	14 (without horizontal bus)	15	20	2100-GKC1_1B-__-__ <sup>[3]</sup>	2100-GJC1_1B-__-__ <sup>[3]</sup>	
			25	2100-GKC1_2B-__-__ <sup>[3]</sup>	2100-GJC1_2B-__-__ <sup>[3]</sup>	
			30	2100-GKC1_3B-__-__ <sup>[3]</sup>	2100-GJC1_3B-__-__ <sup>[3]</sup>	
			35	2100-GKC1_4B-__-__ <sup>[3]</sup>	2100-GJC1_4B-__-__ <sup>[3]</sup>	
	19 (without horizontal bus)	20	20	2100-GKC2_1C-__-__ <sup>[3]</sup>	2100-GJC2_1C-__-__ <sup>[3]</sup>	
			25	2100-GKC2_2C-__-__ <sup>[3]</sup>	2100-GJC2_2C-__-__ <sup>[3]</sup>	
			30	2100-GKC2_3C-__-__ <sup>[3]</sup>	2100-GJC2_3C-__-__ <sup>[3]</sup>	
			35	2100-GKC2_4C-__-__ <sup>[3]</sup>	2100-GJC2_4C-__-__ <sup>[3]</sup>	

- [1] The catalog numbers listed are not complete:
- Select ground bus option B, C, N, or P from table on 14 (only horizontal ground bus is supplied; e.g., 2100-GKC1**B**).
  - Select bus bar bracing, A or B, from table on 14 (horizontal bus is provided in vertical sections; e.g., 2100-GKC1B1D-**A**).
  - Select bus bar material and plating from table on 14 (e.g., 2100-GKC1B1D-**AAT06**).
  - Select trip current number from table on page 23 (e.g., 2100-GKC1B1D-**AAT06-30**).
  - Select circuit breaker type on page 23 (e.g., 2100-GKC1B1D-**AAT06-30CB**).
- [2] Horizontal bus is 5" deeper than standard.
- [3] The catalog numbers listed are not complete:
- Select ground bus option B, C, N, or P from table on 14 (only horizontal ground bus is supplied; e.g., 2100-GKC1**B**).
  - Select trip current number from table on page 23 (e.g., 2100-GKC1B1A-**30**).
  - Select circuit breaker type from table on page 23 (e.g., 2100-GKC1B1A-**30CB**).

Option	Option Number	Description	2100-E Vertical Section	2100-F Vertical Section with Disconnect	2100-G Vertical Section with Circuit Breaker	Delivery program
Grounded Unit Door	-79GD	Hinge mounted ground strap mounted on bottom hinge of unit door. Unit door hinge grounding strap required for IEC applications.	✓	✓	✓	SC
Auxiliary Contacts <sup>[1]</sup>	-98 <sup>[2]</sup>	NORMALLY OPEN: One (1) N.O. auxiliary contact (operated with movement of external handle only)	—	✓	✓	
	-98X <sup>[3]</sup>	NORMALLY OPEN: One (1) N.O. auxiliary contact mounted internally in circuit breaker	—	—	✓	
	-99 <sup>[2]</sup>	NORMALLY CLOSED: One (1) N.C. auxiliary contact (operates with movement of external handle only)	—	✓	✓	
	-99X <sup>[3]</sup>	NORMALLY CLOSED: One (1) N.C. auxiliary contact mounted internally in circuit breaker	—	—	✓	
T-Handle	-111	T-handle latch on unit door	✓ <sup>[4]</sup>	✓	✓	
Shunt Trip	-754	For tripping circuit breaker from remote 120V, 60Hz source	—	—	✓	SC <sup>[5]</sup>
Export Packing Below Deck for Sections	—	Maximum 1-section shipping block. Shipping block is skid mounted and packaged in clear plastic. Packing is not watertight or waterproof. Skid is 2" × 8" construction according to shipping block size. Top is 2" × 4" frame with 1" pine boards. Ends and sides covered with 0.4375" chipboard with 2" × 4" cross members. Two steel bands around outside of container. Extended storage may require space heaters and other considerations.	Available on all SC and PE-I vertical sections.			

- [1] Multiple auxiliary contacts must be group coded by adding the second and third digit of the special feature number to the base digit "9" (e.g., 90-91-98X-99, when group coded, reads 9018X9).
- [2] The maximum number of auxiliary contacts that can be supplied is two (2), in any combination. Contacts actuate with the movement of unit handle to ON or OFF position only. Contacts are not designed to actuate as a result of a circuit breaker trip. For such applications, auxiliary contacts "mounted internally" (98X or 99X) must be selected. Internal auxiliary contacts (98X or 99X) are wired to a 3-point unmounted terminal block.
- [3] The maximum number of auxiliary contacts that can be supplied internally is two (2) N.O. and two (2) N.C. (form C) contacts on F-frame, J-frame, and K-frame circuit breakers.
- [4] Not available in 40" wide sections.
- [5] Additional time required for export packing of SC and PE sections.

### Tables for Configuring Vertical Section Catalog Numbers

#### Voltage Code

21

Fuse Clip Voltage	Voltage Code
250	A
600	C

#### Fuse Clip Designator

22

Disconnect Rating and Fuse Clip Size (Amperes)	Fuse Clip Class	Short Circuit Withstand Rating through 600V	Fuse Clip Designator
30	J	100 kA	24J
	R	100 kA	24R
	H	10 kA	24
60	J	100 kA	25J
	R	100 kA	25R
	H	10 kA	25
100	J	100 kA	26J
	R	100 kA	26R
	H	10 kA	26
200	J	100 kA	27J
	R	100 kA	27R
	H	10 kA	27
400	J	100 kA	28J
	R	100 kA	28R
	H	10 kA	28

#### Trip Current

23

Trip Current (Amperes)	Number
15	30
20	31
30	32
40	34
50	35
60	36
70	37
80	38
90	39
100	40
125	41
150	42
175	43
200	44
225	45
250	46
300	48
350	49
400	50

#### Inverse Time (Thermal Magnetic) Breaker Option \*

24

Rating (Amperes)	Standard Interrupting Capacity		Medium Interrupting Capacity w/ Current Limiter		Medium Interrupting Capacity		High Interrupting Capacity	
	Suffix	Frame	Suffix	Frame	Suffix	Frame	Suffix	Frame
15-50	—	—	CD	I3C-CL	CB	I3C	CM	I6C
60-100	—	—	CD	I3C-CL	CB	I3C	CM	I6C
125-150	—	—	CD	I3C-CL	CB	I3C	CM	I6C
175-225	CT	JD3D	—	—	—	—	CM	JD6D
250-400	CT	K3D	—	—	—	—	CM	K6D

\* Refer to page 234 for circuit breaker interrupting capacity ratings.

## Vertical Sections and IntelliCENTER® Technology

### Basic Sections and Structure Features/Modifications (SC-II and PE-II)

2

25

Basic Sections		Delivery Program
Basic 20" Wide Section	Includes standard features indicated in the tables below and on following pages. Maximum three (3) 20" wide sections per shipping block.	SC-II
25", 30", 35" Wide Section	These sections do not have a vertical wireway. These sections require individual shipping blocks.	
25" Wide Section with 9" Wireway	Section width is 25." Section has a 9" wireway. Maximum of two (2) 25" wide sections with 9" wireway per shipping block. Maximum of one (1) 25" wide section with 9" wireway per shipping block with export packing, or NEMA Type 3R or NEMA Type 4 enclosure.	
Back-to-Back Section	There is no additional charge for assembling 15" or 20" deep sections back-to-back. Back-to-back construction consists of two (2) separate sections mounted together, each with separate bus. Front and rear sections must be equal in width. Six (6) 20" wide sections per shipping block is maximum. A front-to-rear horizontal bus link will be provided only when an incoming line lug compartment, main breaker, or main disconnect is selected. This splice link will be located at the opposite end of the MCC from the incoming line section.	
Corner Section	Inside corner configuration is either 15" deep by 25.125" wide or 20" deep by 30.125" wide and is designed to contain power bus rated 600A-2000A only. There is no available space for the installation of units. Section does not have vertical wireway. See page 105 to select. Corner sections may be selected with an incoming line lug provision (see Bul. 2191M or 2191F, page 64), but are not available in either NEMA Type 3R, Type 4, or back-to-back construction.	
10" Wide Incoming Lug Compartment	This section must be selected as part of a 2-section shipping block, <b>shipped attached to a 20," 25" or 30" wide section</b> . It cannot be selected as free standing or attached to a section with 9" vertical wireway, any 35" wide drive unit, full-section programmable controller, 1600A and 2000A 2192M, or 2000A 2193M, and is not available in NEMA Type 3R, Type 4, or back-to-back construction. For selection information, refer to page 64.	PE-II
71" High Section	This 70.48" high x 15" or 20" deep section will accommodate standard plug-in units up to and including 4.5 space factors. Standard height bus (45" center point) and lower height bus (25.5" center point) are available. Please note the following restrictions for 71" high sections: <ul style="list-style-type: none"> <li>• If top incoming (unless a full section incoming main lug is used) or top frame mounted device is required, select lower height bus.</li> <li>• If bottom incoming (unless full section incoming main lug is used) or bottom frame mounted device is required, select standard bus height.</li> <li>• If frame mounted transformer is required, select standard bus height.</li> <li>• If frame mounted transformer with top incoming main lug is required, select standard height bus and use a full section incoming main lug.</li> <li>• Two frame mounted units cannot be used in a single section.</li> <li>• Top frame mounted units and bottom frame mounted units cannot be mixed in the same line up (e.g., Bulletin 2191, 2192, 2193, 2195, 2196, and 2197 units).</li> <li>• Only the following incoming main lug compartments are available pre-engineered: 300A and 600A in 1.0 space factors, 800A in 1.5 space factors, 1200A in 2.0 space factors, 600A-2000A full section 4.5 space factors.</li> <li>• 6.0 space factor, frame mounted units are not available.</li> </ul> See publication 2100-TD024x-EN-P for more information.	SC-II
71" High Back-to-Back Section	There is no additional charge for assembling 15" or 20" deep sections back-to-back. Back-to-back construction consists of two (2) separate sections mounted together, each with separate bus. Front and rear sections must be equal in width. Six (6) 20" wide sections per shipping block is maximum. A front-to-rear horizontal bus link will be provided only when an incoming line lug compartment, main breaker or main disconnect is selected. This splice link will be located at the opposite end of the MCC from the incoming line section.	

26

Section Features/Modifications		Delivery Program
Cabinet Depth	15" deep	SC-II
	20" deep	
Enclosure Type	NEMA Type 1	
	NEMA Type 1 with gasket (gasketed unit door areas)	
	NEMA Type 12 (totally gasketed enclosure with bottom closing plates)	
	NEMA Type 3R (non-walk-in) front mounted only. Available for internal sections, 30" wide maximum. The external dimension of each NEMA Type 3R cabinet is 5" wider than its internal section and 30" deep (with 20" deep internal section). Not available in back-to-back construction. Refer to publication 2100-TD025x-EN-P. Contact your local Rockwell Automation Sales Office for solid-state equipment (i.e., variable frequency drives, SMCs and PLCs).	PE-II
Bottom Closing Plates	NEMA Type 4 (non-walk-in) stainless steel, front mounted only. Available for internal sections, 30" wide maximum. The external dimension of each NEMA Type 4 section is 5" wider than its internal section and 30" deep (with 20" deep internal section). Not available in back-to-back construction. Available in Canada only. Refer to publication 2100-TD026x-EN-P. Contact your local Rockwell Automation Sales Office for solid-state equipment (i.e., variable frequency drives, SMCs and PLCs).	SC-II
	For NEMA Type 1 and Type 1 with gasket. Bottom closing plates are standard on NEMA Type 12.	
Drip Hood	For corner section NEMA Type 1 and Type 1 with gasket. Bottom closing plates are standard on NEMA Type 12.	SC-II
	Drip hood for NEMA Enclosure Type 1, Type 1 with gasket, and Type 12 only. (Not required for NEMA Type 3R or Type 4.) Drip hood is an overhang on top of a section, providing protection from limited amounts of liquid or dirt dripping and/or running down the front of a section. Select one drip hood per section.	

**Vertical Sections and IntelliCENTER® Technology**  
**Basic Sections and Structure Features/Modifications (SC-II and PE-II)**

Section Features/Modifications, <i>continued</i>				Delivery Program
Power Bus Rating and Material <sup>[1]</sup>  (For 3-phase, 3-wire systems)	Aluminum with tin plating <sup>[1]</sup>	0.125" × 4"	600A	SC-II
		0.188" × 4"	800A	
	Copper with tin plating	0.125" × 3"	600A	
		0.125" × 4"	800A	
		0.250" × 4"	1200A	
		0.500" × 4"	1600A	
	Copper with silver plating	0.625" × 4"	2000A	PE-II
		0.125" × 3"	600A	
		0.125" × 4"	800A	
		0.250" × 4"	1200A	
		0.500" × 4"	1600A	
		0.625" × 4"	2000A	

[1] Vertical bus will be supplied as tin plated copper

Section Features/Modifications		Half-Rated Neutral	Full-Rated Neutral	Main Power Bus Rating	Delivery Program
Power Bus Rating and Material with Neutral Bus <sup>[1]</sup>  (For 3-phase, 4-wire systems)  Neutral bus mounts above or below main power bus.	Aluminum with tin plating <sup>[2]</sup>	0.125" x 4"	0.125" × 4"	600A	PE-II
		0.125" x 4"	0.188" × 4"	800A	
	Copper with tin plating	0.125" × 3"	0.125" × 3"	600A	
		0.125" × 3"	0.125" × 4"	800A	
		0.125" x 4"	0.250" × 4"	1200A	
		0.188" x 4"	0.500" × 4"	1600A	
		0.250" x 4"	0.625" × 4"	2000A	
		Copper with silver plating	0.125" × 3"	0.125" × 3"	
	0.125" × 3"		0.125" × 4"	800A	
	0.125" x 4"		0.250" × 4"	1200A	
0.188" x 4"	0.500" × 4"		1600A		
		0.250" x 4"	0.625" × 4"	2000A	

[1] When used with main incoming line (Bulletin 2191M), Main Switch (Bulletin 2192M) and Main Circuit Breaker (Bulletin 2193M) requires the selection of incoming neutral option (88HN or 88FN). Refer to Appendix, page 247, for neutral bus configuration information. Refer to page 117 for incoming neutral option selection.

[2] Vertical bus will be supplied as tin plated copper

Section Features/Modifications			Delivery Program
Vertical Bus Rating <sup>[1]</sup>	300A tin plated copper vertical bus—0.75" O.D., 0.625" I.D. tube		SC-II
	600A tin plated copper vertical bus—0.75" O.D. rod		
	300A silver plated vertical bus—0.75" O.D., 0.625" I.D. tube		
	600A silver plated vertical bus—0.75" O.D. rod		
Vertical Neutral Bus <sup>[2]</sup>  Requires 25" wide section with 9" wireway	Tin plated copper bus. Mounted in and insulated from 9" vertical wireway. Mechanically connected to horizontal neutral bus. Isolated from the rest of vertical wireway with barriers. To be used for connecting neutral loads or can be used for control voltages that require a connection to the neutral.	Rated 200A (0.1875" × 0.75"). For connection of control power neutral.	PE-II
		Rated 300A (0.25" × 1"). For connection of neutral loads.	
		Rated 600A (0.25" × 1" qty. 2). For connection of neutral loads.	
Neutral Connection Plate <sup>[3]</sup>	0.25" × 2" × 12" copper tin plated bus plate with #6-250 kcmil lug (280A capacity). Insulated from and mounted to either top or bottom horizontal wireway.		SC-II
	0.25" × 2" × 12" copper tin plated bus plate with #6-250 kcmil lug (280A capacity). Insulated from and mounted to either top or bottom horizontal wireway. Cable connection provided to horizontal neutral bus. <sup>[2]</sup>		PE-II
	0.25" x 2" x 12" copper silver plated bus plate with #6-250 kcmil lug (280A capacity). Insulated from and mounted to either top or bottom horizontal wireway.		
	0.25" x 2" x 12" copper silver plated bus plate with #6-250 kcmil lug (280A capacity). Insulated from and mounted to either top or bottom horizontal wireway. Cable connection provided to horizontal neutral bus. <sup>[2]</sup>		

[1] Plating of horizontal bus and vertical bus must be the same.

[2] Requires horizontal neutral bus. See Power Bus Rating and Material with Neutral Bus in table above.

[3] A neutral connection plate can be used only in sections with a vertical wireway. Not available in sections with 6.0 space factor frame mounted units. Not available in top of section with frame mounted unit mounted at top of section. Not available in bottom of section with frame mounted unit mounted at bottom of section.

Section Features/Modifications, <i>continued</i>			Delivery Program	
Bracing <sup>[1]</sup>	42kA (rms symmetrical)		SC-II	
	65kA (rms symmetrical)			
	100kA series coordinated. Provides 65kA (rms symmetrical) bracing in each section. Must be used in coordination with 600A-2000A horizontal bus and one of the following main incoming devices: 100, 200, 400, or 600A, 2192M with Class R or J fusing 600, 800, 1200, 1600, or 2000A, 2192M with Class L fusing JDO 250A Frame 2193M, 480V or less KO 400A Frame 2193M, 480V or less LDC 600A Frame 2193M, 480V or less NDC 800A Frame 2193M, 480V or less NDC 1200A Frame 2193M, 480V or less All starters, feeder units, etc. must have a short circuit withstand rating capable of interrupting the available fault current to the MCC.			
Ground Bus Unplated copper <sup>[2]</sup>	0.25" × 1" horizontal ground bus		SC-II	
	0.25" × 2" horizontal ground bus			
	Two (2) 0.25" × 1" horizontal ground bus top and bottom (cable interconnected)			
	Two (2) 0.25" × 2" horizontal ground bus top and bottom (cable interconnected)			
Ground Bus Tin Plated copper <sup>[2]</sup>	0.25" × 1" horizontal ground bus		SC-II	
	0.25" × 2" horizontal ground bus			
	Two (2) 0.25" × 1" horizontal ground bus top and bottom (cable interconnected)			
	Two (2) 0.25" × 2" horizontal ground bus top and bottom (cable interconnected)			
Vertical Ground Bus	0.188" × 0.75" vertical plug-in steel ground bus	Steel	SC-II	
	0.188" × 0.75" vertical plug-in ground bus	Unplated copper		
	0.188" × 0.75" vertical ground bus for grounding unit load			
	0.188" × 0.75" vertical plug-in ground bus	Tin plated copper		
	0.188" × 0.75" vertical ground bus for grounding unit load			
Horizontal Power Bus Splice Kit	Splice bars, hardware, and installation instructions for 3-phase splicing. One (1) kit required per shipping split on front mounted lineups. Two (2) kits required per shipping split for back-to-back construction.	Aluminum tin plated bus	600A	PE-II
			800A	
		Copper tin plated bus	600A	
			800A	
			1200A	
			1600A	
		Copper silver plated bus	2000A	
			600A	
			800A	
			1200A	
	1600A			
	2000A			

[1] Contact your local Rockwell Automation Sales Office when specifying 100kA series coordinated bracing for "Add to existing" sections.

[2] Standard ground bus lugs provided for horizontal ground bus options are: no main = no lug, 2191M = 1 lug, 2192M or 2193M = 2 lugs. Lugs accept one, #6AWG-250kcmil cable.

Section Features/Modifications, <i>continued</i>		Main Power Bus (Phase A, B, C) Rating and Material	Delivery Program
Horizontal Neutral Bus Splice Kit	Splice bar hardware (installation instructions included in power bus splice kit). One (1) kit required per shipping split on front mounted lineups. Two (2) kits required per shipping split for back-to-back construction.	600A Aluminum with Tin Plating	PE-II
		800A Aluminum with Tin Plating	
		600A Copper with Tin Plating	
		800A Copper with Tin Plating	
		1200A Copper with Tin Plating	
		1600A Copper with Tin Plating	
		2000A Copper with Tin Plating	
		600A Copper with Silver Plating	
		800A Copper with Silver Plating	
		1200A Copper with Silver Plating	
		1600A Copper with Silver Plating	
		2000A Copper with Silver Plating	

Section Features/Modifications, <i>continued</i>			Delivery Program
Horizontal Ground Bus Splice Kit	One (1)—0.25" × 1" (unplated copper)	For applications utilizing ground bus mounted on both top and bottom or from back-to-back line ups, two (2) ground bus splice kits are required for joining each shipping block.	SC-II
	Two (2)—0.25" × 1" (unplated copper)		
	One (1)—0.25" × 1" (tin plated copper)		
	Two (2)—0.25" × 1" (tin plated copper)		
NO-OX-ID®	NO-OX-ID compound on bus		
Pullbox <sup>[1]</sup>	12" high × 15" deep or 20" deep (except corner sections)		
Shutters	For isolation of plug-in stab openings—automatic		
	For isolation of plug-in stab openings—manual		
Protective Caps	For unused plug-in stab openings		
Unit Isolating Barriers	For closing the wire opening between unit and vertical wireway		
DeviceNet Connector Covers	For covering the unused DeviceNet connectors in the vertical wireway of a DeviceNet MCC		
Wireway Tie Bars	Five (5) cable tie bars in vertical wireway		
Outgoing Equipment Ground Lug	One (1) #6-250 kcmil lug mounted on horizontal ground bus in addition to lug provided		
T-Handle	T-handle latch on vertical wireway door		
Master Nameplates	Located on top horizontal wireway cover of the second vertical section in lineup, 2" × 6"		
Stainless Steel Nameplate Screws	Stainless steel nameplate screws for master nameplate (2 per nameplate)		
External Mounting Channel <sup>[2]</sup>	Two (2) 1.5" × 3" mounting channels <b>NOTE:</b> Adding an external mounting channel will add 1.5" to height of section		
NEMA Type 3R Lifting Angle	Optional lifting angle for NEMA Type 3R cabinets only. This angle is not removable. <b>NOTE:</b> Adding the lifting angle will add 3.63" to the height of the section		PE-II
Space Heaters and Thermostat (Requires user supplied source of power)	Space heater with thermostat in each section	200 watt, 120 volt strip heater. Thermostat set at 21° C (70° F).	SC-II
	For two-section shipping block, one space heater is supplied in each section with a single thermostat control located in right-hand section		
	For three-section shipping block, one space heater is supplied in each section with a single thermostat control located in center section		
	Space heater with thermostat in each section	200 watt, 240 volt strip heater. Thermostat set at 21° C (70° F).	
	For two-section shipping block, one space heater is supplied in each section with a single thermostat control located in right-hand section		
	For three-section shipping block, one space heater is supplied in each section with a single thermostat control located in center section		
Export Packing Below Deck for Sections	Maximum 3-section shipping block. Shipping block is skid mounted and packaged in clear plastic. Packing is not watertight or waterproof. Skid is 2" × 8" construction according to shipping block size. Top is 2" × 4" frame with 0.438" orientated strand board (OSB). Ends and sides covered with 0.438" orientated strand board (OSB) with 2" × 4" cross members. Two steel bands around outside of container. Extended storage may require space heaters and other considerations.		SC-II <sup>[3]</sup>

[1] Available on NEMA Enclosure Type 1, Type 1 with gasket and Type 12 sections only.

[2] External mounting channel is shipped attached to MCC section(s).

[3] Additional time required for export packing of SC-II and PE-II sections.

**CENTERLINE 2100 Motor Control Center with IntelliCENTER® Technology**

- CENTERLINE 2100 Motor Control Center with IntelliCENTER technology provides CENTERLINE 2100 MCCs with sections having integrated DeviceNet cabling and CENTERLINE 2100 units with DeviceNet capable components. The DeviceNet cabling, consisting of trunk line and drop lines, is routed through the sections and into the individual units, allowing the devices to communicate via DeviceNet. A complete DeviceNet system includes cabling, power supply, scanner module and the necessary DeviceNet components in the MCC units.
- The trunk line is built in to the sections and routed behind barriers. The drop lines are routed from each unit to the DeviceNet connectors in the vertical wireway of each vertical section. The DeviceNet cable is rated 8 amperes, 600 volts for use with a Class 1 power limited circuit. Six (6) DeviceNet connectors built into the back of the vertical wireway of each standard section provide a convenient method for the MCC units to connect to the trunk line.
- Units may communicate over DeviceNet via components such as an E3 solid-state overload relay, DeviceNet Starter Auxiliary (DSA) or DeviceNet communication module such as 20-COMM-D. These units are supplied with a DeviceNet cable for connecting to a DeviceNet connector in the vertical wireway. DeviceNet nodes are addressed per factory standards or per customer specified information. Electronic Data Sheets (EDS) files on CD are shipped with the MCC.
- For more information on DeviceNet, refer to publication DNET-BR002x-EN-P, DeviceNet Brochure, publication DNET-UM072x-EN-P, *DeviceNet Media Design and Installation Manual* and publication 2100-TD019x-EN-P, *DeviceNet Motor Control Centers*.

The CENTERLINE 2100 Motor Control Center with IntelliCENTER technology can consist of integrated hardware, software and communication in one centralized package. The available IntelliCENTER software provides pre-configured screens which provide real-time data, trending, component history, wiring diagrams, user manuals and spare parts. See page 30 for selection.

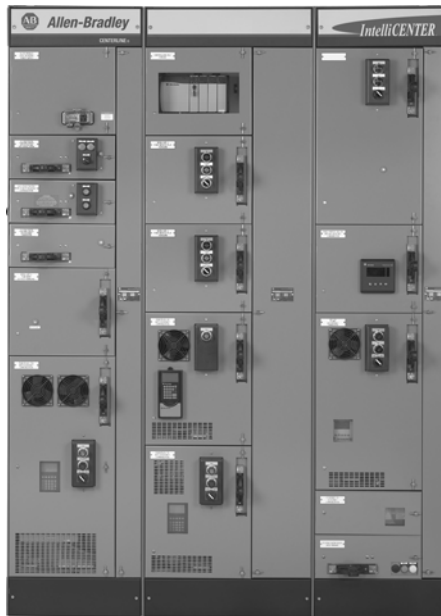

Section Features	Description	Delivery Program
IntelliCENTER technology	Includes DeviceNet trunk line, drop cable from each unit to DeviceNet port in vertical wireway and plug-in terminating resistor kit. Includes DeviceNet node addressing per factory standards or per customer specified information. A single MCC is allowed to be configured to contain up to five independent networks. Maximum of 17 sections per network for MCCs on the SC or PE delivery program. IntelliCENTER software and documentation CD available, see description on page 30. Available only for sections which contain horizontal power bus.	SC-II

IntelliCENTER Software

2 **NOTE:** All IntelliCENTER software is copyright protected and for installation on one personal computer *only*.

34

Description		Delivery Program
IntelliCENTER <sup>[1]</sup> Full Version  Catalog Number: 2101A-INTLCNTR	The IntelliCENTER software replicates the MCC lineup on a computer screen, complete with nameplates and indicators on each door to show status (on, off, warning, fault, communication failure). Graphical views of individual MCC units display device data allowing users to quickly view critical amperes, time-to-trip, trip cause, ground fault amperes and on/off status. Each screen is preconfigured to show the parameters typically of greatest interest, and users easily can customize parameters. Many screens feature trending graphs and analog dials. The software also provides spare parts information, AutoCAD documentation and event logging. Requires Documentation CD; see below.  The IntelliCENTER software also contains ActiveX controls. This allows key views of the software to be displayed inside Human Machine Interfaces (HMIs) such as RSVIEW.	SC
Documentation CD <sup>[1][2]</sup>  Catalog Number: 2101A-INTLDOC	The Documentation CD is the second component of the IntelliCENTER software. The CD contains data files specific to a particular MCC. This information includes unit nameplates, unit details, wiring diagrams, user manuals, spare parts and other details.	
IntelliCENTER <sup>[1]</sup> ActiveX Only Version  Catalog Number: 2101A-INTLCNTR-X	The IntelliCENTER ActiveX Only Version software contains only the ActiveX controls necessary to include the IntelliCENTER views (elevation, monitor, electronic documentation, CAD diagrams, event log and spreadsheet) within an HMI.  <b>Note: At least one copy of IntelliCENTER Full Version is required to perform maintenance tasks such as moving units, adding units and changing units in the IntelliCENTER software.</b>	

[1] Must be ordered separately from MCC.

[2] For MCCs ordered prior to September 1, 2006, please contact your local Rockwell Automation Sales Office for availability.

**Minimum PC Requirements for running IntelliCENTER Software:**

- **Operating System:** Windows 2000 SP4 or XP (English/Western European Versions)
- **Processor:** Pentium IV processor, 1.4 GHz minimum
- **Video Resolution:** 1024 x 768 resolution with true color (24 bit or better)
- **CD-ROM drive:** 4X (16X recommended)
- **Hard Disk space:** 600 MB free disk space
- **Mouse:** Microsoft compatible
- **RAM:** 256 MB—Windows 2000 SP4 or XP (512 MB recommended)

**Equipment Necessary for Connection of a Computer via DeviceNet, ControlNet or Ethernet:**

**DeviceNet**

- Laptop computer: 1784-PCD DeviceNet PC interface card and 1784-PCD1 cable
- Desktop computer: 1784-PCIDS
- RS-232 interface (reduced performance): 1770-KFD DeviceNet interface module

**NOTE:** 2100H-ICPC120 patch cable is necessary for connecting interface (laptop, desktop, RS-232) to IntelliCENTER MCC wireway

**ControlNet**

- Laptop computer: 1784-PCC ControlNet PC interface card and 1784-C1 cable
- Desktop computer: 1784-PCIC ControlNet PC interface card and 1786-TPR ControlNet tap

**NOTE:** Consult publication CNET-IN002x-EN-P, *ControlNet Coax Media Planning and Installation Guide*, for configuration and installation of ControlNet cable

**Ethernet**

- Laptop or desktop computer: consult local computer support personnel for Ethernet interface requirements

**Recommended Additional Software**

- RSNetWorx for DeviceNet—used for configuring DeviceNet nodes, saving parameters, and communicating to all types of DeviceNet components (sensors, non-Allen-Bradley products and other products not found in MCCs)
- RSNetWorx for ControlNet—used for configuring ControlNet devices including ControlNet to DeviceNet bridge

\* The IntelliCENTER software is a monitoring/communication software package requiring a very large amount of processor speed to function efficiently and quickly. The processor speeds listed will allow the software to function correctly. However, for speed and efficiency, it is recommended to use the fastest Pentium IV class (or better) processor available.

# Units

*Please read this important information for ordering units*

## Select sections separately from units

Units having DeviceNet options, ordered separately from vertical sections, will be supplied with a 48" DeviceNet drop cable for connecting the DeviceNet device to a DeviceNet port in the vertical wireway of the existing CENTERLINE 2100 MCC with IntelliCENTER technology

## Wiring Type

Units are available with either Type A or Type B wiring. Catalog numbers are for Type B wiring. To order Type A wired units, substitute the letter B in the catalog number with the letter A. For example, change 2103LB-BKBD-30CB to 2103LA-BKBD-30CB

## Units include door, unit support pan, hinges and hinge pins

## Overload Relays

Starter units include a Bulletin 592 eutectic alloy overload relay as standard. See Options section for electronic overload relays

## Heater Elements

Heater elements are offered on pages 227 through 231.

## Power Fuses

Factory installed power fuses are available for most fusible units. See pages 207-208 for selection

## Delivery Programs

Delivery programs are listed in all tables under the column marked "Delivery Program." See page 3 for more delivery program information

## 71" High Sections

71" high sections will accommodate 4.5 space factor (maximum) units. For 71" high section restrictions, see page 24.

## Bulletin 2113, Size 1, with Control Transformer Shown

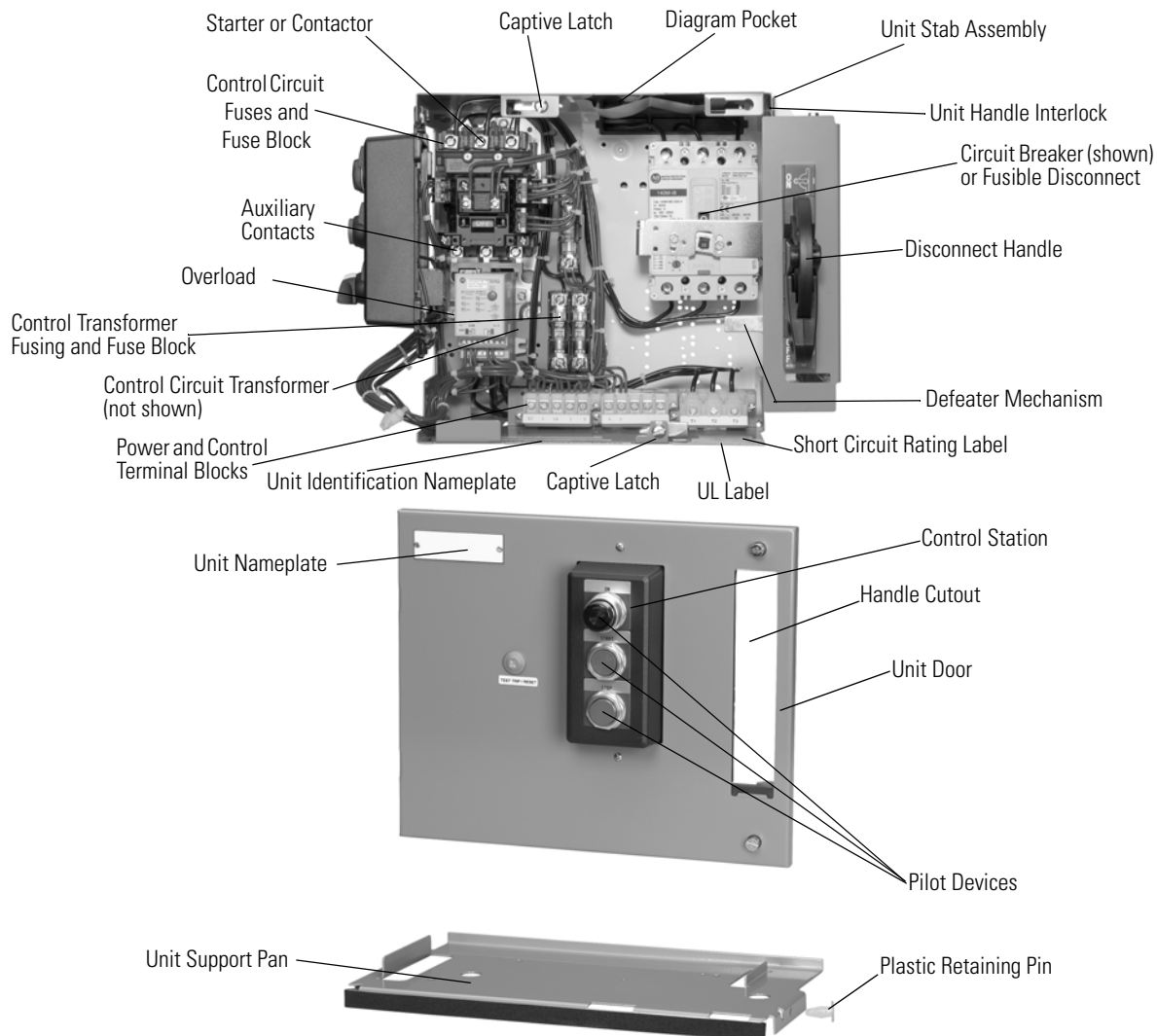



# Contactor and Starter Units

## Bulletin 2102L and 2103L

### Combination Full-Voltage Lighting Contactor Units (FVLC) ..... 35

These combination lighting contactor units are supplied with an Allen-Bradley 500L AC contactor and either a fusible disconnect or circuit breaker. They are rated 30A through 300A. Each unit is provided as a NEMA Class I, Type B-T unit with terminals mounted in the unit for connection to remote devices.



## Bulletin 2106 and 2107

### Combination Full Voltage Reversing Starter Units (FVR) ..... 38

These combination full voltage reversing starter units are supplied with an Allen-Bradley Bulletin 505 reversing starter and either a fusible disconnect or a circuit breaker. The Bulletin 2106 and 2107 starters are rated for NEMA sizes 1 through 5 and are mechanically and electrically interlocked to avoid both contactors being closed simultaneously. Each unit is provided as a NEMA Class I, Type B-T unit with terminals mounted in the unit for connection to remote devices. Full voltage reversing starter units are available with a eutectic alloy, E1 Plus or E3 Plus electronic overload relay.

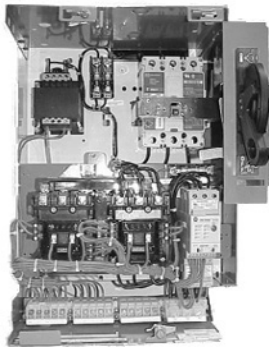

## Bulletin 2106 and 2107 Space Saving NEMA

### Combination Full Voltage Reversing Starter Units (FVR) ..... 40

These combination full voltage reversing starter units offer a space saving alternative while utilizing an Allen-Bradley Bulletin 300 reversing starter and either a fused disconnect or a circuit breaker. The Bulletin 2106 Space Saving NEMA reversing starters are rated for NEMA Size 1 applications and the Bulletin 2107 Space Saving NEMA reversing starters are rated for NEMA Size 1-3 applications. The contactors are mechanically and electrically interlocked to avoid both contactors being closed simultaneously. Each unit is provided as a NEMA Class I, Type B-D unit with terminals mounted in the unit for connections to remote devices. These full voltage reversing units are available with E1 Plus or E3 Plus electronic overload relays.



## Bulletin 2112, 2112 Vacuum, 2113, and 2113 Vacuum

### Combination Full Voltage Non-Reversing Starter Units (FVNR) ..... 42

These combination full voltage non-reversing starter units are supplied with an Allen-Bradley Bulletin 509 starter (starter units with vacuum contactors use Allen-Bradley Bulletin 1102C contactors) and either a fusible disconnect or a circuit breaker. The full voltage non-reversing starters are rated for NEMA sizes 1 through 6 (starter units with vacuum contactors are rated 200A, 400A, or 600A). Each unit is provided as a NEMA Class I, Type B-T unit, with terminals mounted in the unit for connection to remote devices. Full voltage non-reversing starter units are available with a eutectic alloy, E1 Plus or E3 Plus electronic overload relay.

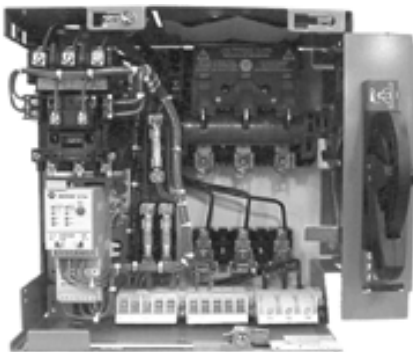

For more details on Bulletin 500 contactors and starters, see publication 500-BR010x-EN-P, NEMA Power Components, and publication A116-CA001x-EN-P Allen-Bradley Industrial Controls Catalog. For more details on Bulletin 300 starters, see publication 300-SG001x-EN-P, Bulletin 300 Starters Selection Guide. For more details on Bulletin 1102C vacuum contactors, see publication 500-SG005x-EN-P, Bulletin 512V, 513V, 1102C, 1109, 1232V, 1233V Selection Guide.

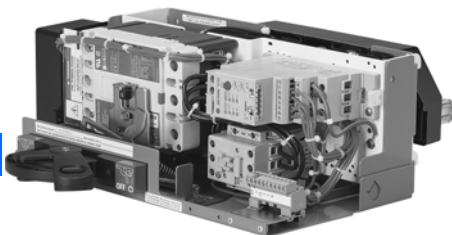

**Bulletin 2112 and 2113 Space Saving NEMA  
Combination Full Voltage Non-Reversing Starter Units (FVNR) ..... 46**

These combination full voltage non-reversing starter units offer a space saving alternative while utilizing an Allen-Bradley Bulletin 300 starter and either a fused disconnect or a circuit breaker. The Bulletin 2112 Space Saving NEMA non-reversing starter units are rated for NEMA Size 1 applications and the Bulletin 2113 Space Saving NEMA non-reversing starter units are rated for NEMA Size 1-4 applications. Each unit is provided as a NEMA Class I, Type B-D unit with terminals mounted in the unit for connections to remote devices. These full voltage non-reversing units are available with E1 Plus or E3 electronic overload relays.

**Bulletin 2122E, 2123E, 2122F and 2123F  
Combination 2-Speed Starter Units (TS2W and TS1W) ..... 48**

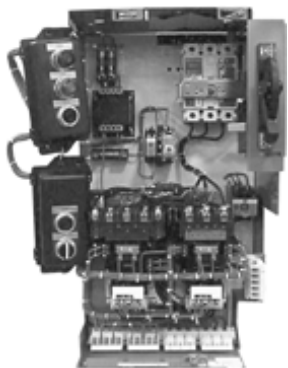

These combination two-speed starter units are supplied with an Allen-Bradley Bulletin 520 starter and either a fusible disconnect or a circuit breaker. The 2122 and 2123 starter units are designed for use with motors having separate windings or consequent pole windings. The 2122E, 2123E, 2122F and 2123F are rated for NEMA sizes 1 through 5. Each unit is provided as a NEMA Class I, Type B-T unit, with terminals mounted in the unit for connection of remote devices. Two-speed starter units are available with a eutectic alloy or E1 Plus overload relay.

**Bulletin 2126E, 2127E, 2126F, 2127F, 2126J, 2127J, 2126K and 2127K  
Combination 2-Speed Reversing Starter Units (TSR2W and TSR1W) ..... 52**

These combination two-speed starter units are supplied with Allen-Bradley Bulletin 505 and 520 starters and either a fusible disconnect or a circuit breaker. The Bulletin 2126 and 2127 starter units are designed for use with motors having separate windings or consequent pole windings. Each unit is provided as a NEMA Class I, Type B-T unit, with terminals mounted in the unit for connection of remote devices.

- The 2126E and 2127E are two-speed reversing 2-winding starter units and are rated for NEMA sizes 1 and 2.
- The 2126F and 2127F are two-speed reversing 1-winding starter units and are rated for NEMA sizes 1 and 2.
- The 2126J and 2127J are two-speed reversing in low only 2-winding starter units rated for NEMA sizes 1 and 2.
- The 2126K and 2127K are two-speed reversing in low only 1-winding starter units rated for NEMA sizes 1 and 2.

Two speed reversing starter units are available with a eutectic alloy or E1 Plus overload relay.

For more details on Bulletin 500 contactors and starters, see publication 500-BR010x-EN-P, NEMA Power Components, and publication A116-CA001x-EN-P Allen-Bradley Industrial Controls Catalog. For more details on Bulletin 300 starters, see publication 300-SG001x-EN-P, Bulletin 300 Starters Selection Guide.

## Catalog Number Explanation - Bulletin 2102L and 2103L Full Voltage Lighting Contactors (FVLC)

- Allen-Bradley Bulletin 500L AC contactor with a fusible disconnect or circuit breaker
- Rated 30A - 300A
- NEMA Class I, Type B with terminals mounted on the unit



<b>2102L</b>		<b>B</b>	-	<b>B</b>	<b>K</b>	<b>B</b>	-	<b>24J</b>	-	<b>6P</b>
<b>2103L</b>		<b>B</b>	-	<b>B</b>	<b>K</b>	<b>B</b>	-	<b>30CB</b>	-	<b>6P</b>
Bulletin Number		Wiring Type		Rating Amperes	NEMA Enclosure Type	Control Voltage Type		Fuse Clip Ratings and Class or Trip Current and Circuit Breaker Type		Option
35A				35C		35E		35G		
<b>Code</b>	<b>Type</b>	<b>Code</b>	<b>Rating Amperes</b>	<b>Code</b>	<b>Control Voltage Type</b>	<b>Code</b>	<b>Option</b>			
2102L	Full Voltage Lighting Contactor (FVLC) with Fusible Disconnect	Z	30A (0.5 Space Factor)		See Table on Page 205		See Options section beginning on Page 107.			
2103L	Full Voltage Lighting Contactor (FVLC) with Circuit Breaker	B	30A							
		C	60A							
		D	100A							
		E	200A							
		F	300A							
35B				35D				35F		
<b>Code</b>	<b>Wiring Type</b>	<b>Code</b>	<b>NEMA Enclosure Type</b>	<b>Code</b>	<b>Fuse Clip Ratings and Class or Trip Current Circuit Breaker Type</b>					
A	Type A	K	NEMA Type 1 or Type 1 with gasket	2102L - "24J"	Fuse Clip Rating and Class. See Table on Page 208					
B	Type B	J	NEMA Type 12	2103L - "30CB"	Trip Current and Circuit Breaker Type. See Table on page 209 and table on page 210.					

## Contactor and Starter Units

### Bulletin 2102L

#### Full Voltage Lighting Contactor Unit with Fusible Disconnect Switch (FVLC)

- See page 33 for product description.
- For unit sizing, select unit rating based on 125% of actual load amperes.
- Unit includes three (3) power poles and one (1) hold-in contact.

**NOTE:** In order to address the heating effects from loads containing a high degree of harmonic content, it may be necessary to oversize the field conductors (especially neutrals), use k-factor lighting transformers and oversize the lighting contactor units (increase by 50%); for high harmonic load applications, Contact your local Rockwell Automation Sales Office.

4

36

Rating (Amperes) [1]	Transformer Primary Switching kVA [2]										Fuse Clip (See Appendix for short circuit withstand ratings.)		Space Factor	Catalog Number [3] Wiring Type B—Class I		Delivery Program
	208V		240V		380V- 415V		480V		600V		Rating (Amperes)	Class		NEMA Type 1 and Type 1 w/ gasket	NEMA Type 12	
	1Ø	3Ø	1Ø	3Ø	1Ø	3Ø	1Ø	3Ø	1Ø	3Ø						
30 [4]	1.2	3.6	2.4	4.3	2.8	7.1	4.9	8.5	6.2	11	30	CC, J	0.5	2102LB-ZK_ _ _	2102LB-ZJ_ _ _	SC
30	1.2	3.6	2.4	4.3	2.8	7.1	4.9	8.5	6.2	11	30	CC, J, R, H	1.0	2102LB-BK_ _ _	2102LB-BJ_ _ _	
60	2.1	6.3	4.1	7.2	6.8	11.8	8.3	14	10	18	30 60	J, R, H	1.0	2102LB-CK_ _ _	2102LB-CJ_ _ _	
100	4.1	12	8.1	14	13.3	23.3	16	28	20	35	60 100		2.5	2102LB-DK_ _ _	2102LB-DJ_ _ _	
200	6.8	20	14	23	22.5	39	27	47	34	59	100 200		3.0	2102LB-EK_ _ _	2102LB-EJ_ _ _	PE
300	14	41	27	47	45	78.3	54	94	68	117	200 400	4.0	2102LB-FK_ _ _	2102LB-FJ_ _ _		

[1] Ampere ratings apply to non-motor loads such as fluorescent ballasts, mercury vapor lamps and resistive heating. Tungsten lamp current ratings are limited to applications 480 volts line-to-line (277 volts line-to-neutral) maximum.

[2] Ratings are based on the contactor being used to switch transformers having an inrush of not more than 20 times their rated full load current, regardless of the nature of the secondary load. Ratings do not apply to transformers used in resistance welder service.

[3] The catalog numbers listed are not complete:

- Select control voltage type from table on page 205 (e.g., 2102LB-BK**BD**).
- Refer to table above to select fuse clip. Then select designator from table on page 208 (e.g., 2102LB-BKBD-**24J**).
- To select optional power fuse, and select from table on page 208 (e.g., 2102LB-BKBD-24J-**607G**).
- For fuse rating, based on disconnect rating see publication 2100-TD003x-EN-P.

[4] Separate or transformer control only, except 208V (where separate control only). These units have horizontal handles, Bulletin 194R fused disconnect switch, up to four (4) Bulletin 800F pilot devices and one (1) 10-pt. pull-apart control terminal block with #16 AWG control wire only. One (1) 3-pole power terminal block is supplied as standard.

- See page 33 for product description.
- For unit sizing, select unit rating based on 125% of actual load amperes.
- Unit includes three (3) power poles and one (1) hold-in contact.

**NOTE:** In order to address the heating effects from loads containing a high degree of harmonic content, it may be necessary to oversize the field conductors (especially neutrals), use k-factor lighting transformers and oversize the lighting contactor units (increase by 50%).

Rating (Amperes) [1]	Transformer Primary Switching kVA [2]										Space Factor	Catalog Number [3] Wiring Type B—Class I		Delivery Program
	208V		240V		380V–415V		480V		600V			NEMA Type 1 and Type 1 w/ gasket	NEMA Type 12	
	1Ø	3Ø	1Ø	3Ø	1Ø	3Ø	1Ø	3Ø	1Ø	3Ø				
30 [4]	1.2	3.6	2.4	4.3	2.8	7.1	4.9	8.5	6.2	11	0.5	2103LB-ZK_ _ _	2103LB-ZJ_ _ _	SC
30	1.2	3.6	2.4	4.3	2.8	7.1	4.9	8.5	6.2	11	1.0	2103LB-BK_ _ _	2103LB-BJ_ _ _	
DUAL 30 [5]	1.2	3.6	2.4	4.3	2.8	7.1	4.9	8.5	6.2	11	1.5	2103LB-BK_ _ _ [6]	2103LB-BJ_ _ _ [6]	
60	2.1	6.3	4.1	7.2	6.8	11.8	8.3	14	10	18	1.0	2103LB-CK_ _ _	2103LB-CJ_ _ _	
DUAL 60 [5]	2.1	6.3	4.1	7.2	6.8	11.8	8.3	14	10	18	1.5	2103LB-CK_ _ _ [6]	2103LB-CJ_ _ _ [6]	
100	4.1	12	8.1	14	13.3	23.3	16	28	20	35	1.5	2103LB-DK_ _ _	2103LB-DJ_ _ _	
200	6.8	20	14	23	22.5	39	27	47	34	59	2.5	2103LB-EK_ _ _	2103LB-EJ_ _ _	PE
300	14	41	27	47	45	78.3	54	94	68	117	3.5	2103LB-FK_ _ _	2103LB-FJ_ _ _	

- [1] Ampere ratings apply to non-motor loads such as fluorescent ballasts, mercury vapor lamps and resistive heating. Tungsten lamp current ratings are limited to applications 480 volts line-to-line (277 volts line-to-neutral) maximum.
- [2] Ratings are based on the contactor being used to switch transformers having an inrush of not more than 20 times their rated full load current, regardless of the nature of the secondary load. Ratings do not apply to transformers used in resistance welder service.
- [3] The catalog numbers listed are not complete:
- Select control voltage type from table on page 205 (e.g., 2103LB-BKBD).
  - Select trip current from table on page 209 (e.g., 2103LB-BKBD-30).
  - Select circuit breaker from Circuit Breaker Type table on page 210 (e.g., 2103LB-BKBD-30CB).
- [4] Separate or transformer control only, except 208V (where separate control only). These units have horizontal handles, up to four (4) Bulletin 800F pilot devices and one (1) 10-pt. pull-apart control terminal block with #16 AWG control wire only. One (1) 3-pole power terminal block is supplied as standard.
- [5] Dual mounted unit supplied without power terminal blocks.
- [6] To dual mount combination lighting contactors in one unit:
- Select two trip current numbers from table on page 209 (e.g., 2103LB-BKBD-3032).
  - Then select circuit breaker from Circuit Breaker Type table on page 209 (e.g., 2103LB-BKBD-3032CB).

## Contactor and Starter Units

### Catalog Number Explanation - Bulletin 2106 and 2107 Full Voltage Reversing Starters (FVR)

- Allen-Bradley Bulletin 505 reversing starter with a fusible disconnect or circuit breaker
- NEMA Sizes 1-5
- NEMA Class I, Type B wiring with terminals mounted in the unit
- Available with eutectic alloy, E1 Plus or E3 Plus electronic overload relays

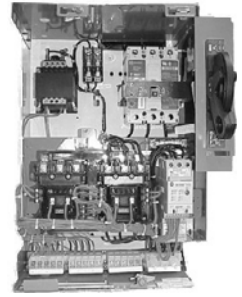

4

38

<b>2106</b>	<b>B</b>	-	<b>B</b>	<b>A</b>	<b>B</b>	-	<b>41-24J</b>	-	<b>6P</b>
<b>2107</b>	<b>B</b>	-	<b>B</b>	<b>A</b>	<b>B</b>	-	<b>41CA</b>	-	<b>6P</b>
<i>Bulletin Number</i>	<i>Wiring Type</i>		<i>NEMA Size</i>	<i>NEMA Enclosure Type</i>	<i>Control Voltage Type</i>		<i>Horsepower and Disconnecting Means</i>		<i>Options</i>

Code	Type
2106	Full Voltage Reversing (FVR) with Fusible Disconnect
2107	Full Voltage Reversing (FVR) with Circuit Breaker

Code	Wiring Type
A	Type A
B	Type B

Code	NEMA Size
B	1
C	2
D	3
E	4
F	5

Code	NEMA Enclosure Type
A	NEMA Type 1 or Type 1 with gasket with external reset button
K	NEMA Type 1 or Type 1 with gasket without external reset button
D	NEMA Type 12 with external reset button
J	NEMA Type 12 without external reset button

Code	Control Voltage Type
See Table on Page 205	

Code	Fuse Clip Ratings and Class or Trip Current Circuit Breaker Type
2106 - "41-24J"	"41" Horsepower Code. See Horsepower Table on Page 206. "24J" Fuse Clip Rating and Class See Fuse Clip Designator table on page 207
2107 - "41CA"	"41_" Horsepower Code. See Horsepower Table on page 206 "_CA" Circuit Breaker Type. See Table on Circuit Breaker Type Table on page 211.

Code	Options
See Options section beginning on Page 107.	

See page 33 for product description.

4

NEMA Size	Horsepower				Fuse Clip (See Appendix for short circuit withstand ratings.)		Space Factor	Catalog Number <sup>[1]</sup> Wiring Type B—Class I		Delivery Program
	208V	240V	380V–415V	480V/600V	Rating (Amperes)	Class		NEMA Type 1 and Type 1 w/ gasket	NEMA Type 12	
1	0.125-7.5	0.125-7.5	0.125-10	0.125-10	30	CC, J, R, H, HRCII-C	1.5	2106B-BA_ _ _	2106B-BD_ _ _	SC
					60	J, R, H, HRCII-C				
2	10	10-15	15-25	15-25	30 <sup>[2]</sup>	J, R, H, HRCII-C	1.5	2106B-CA_ _ _	2106B-CD_ _ _	
					60	J, R, H, HRCII-C				
					100	R, H, HRCII-C				
3	15-25	20-30	30-50	30-50	60 <sup>[2]</sup>	J, R, H, HRCII-C	3.0	2106B-DA_ _ _	2106B-DD_ _ _	
					100	J, R, H, HRCII-C				
					200	J, R, H, HRCII-C				
4	30-40	40-50	60-75	60-100	100 <sup>[2]</sup>	J, R, H, HRCII-C	4.0	2106B-EA_ _ _	2106B-ED_ _ _	
					200	J, R, H, HRCII-C				
					400	J				
5	50-75	60-100	100-150	125-200	200 <sup>[2]</sup>	J, R, H, HRCII-C	6.0 <sup>[4]</sup> , 20"W	2106B-FA_ _ _	2106B-FD_ _ _	PE-II
					400	J, R, H, HRCII-C				
					600	J				

- [1] The catalog numbers listed are not complete:
- Select control voltage type from table on page 205 (e.g., 2106B-BABD).
  - Select horsepower from table on page 206 (e.g., 2106B-BABD-31).
  - If power fuse will NOT be selected, select fuse clip from table above. Then select clip designator from table on page 207 (e.g., 2106B-BABD-31-24J).
  - If power fuse WILL be selected, first select clip designator from table on page 207 (e.g., 2106B-BABD-31-20J). Then select power fuse from table on page 207 (e.g., 2106B-BABD-31GT-20J).
  - For fuse rating based on load horsepower, see publication 2100-TD003x-EN-P.
  - The catalog numbers listed include an external reset button for the overload relay. To order catalog numbers **without** the external reset button, replace the letter "A" with the letter "K" (e.g., 2106B-BK\_ \_ \_) or replace the letter "D" with the letter "J" (e.g., 2106B-BJ\_ \_ \_).
- [2] Available on 480V and 600V applications only.
- [3] For 208V and 240V applications with Class R or H fuses, unit only requires 1.5 space factors.
- [4] Frame mounted unit, section does not have vertical wireway.

See page 33 for product description.

NEMA Size	Horsepower				Space Factor	Catalog Number <sup>[1]</sup> Wiring Type B—Class I		Delivery Program
	208V	240V	380V–415V	480V/600V		NEMA Type 1 and Type 1 w/ gasket	NEMA Type 12	
1	0.125-7.5	0.125-7.5	0.125-10	0.125-10	1.5	2107B-BA_ _ _	2107B-BD_ _ _	SC
2	10	10-15	15-25	15-25	1.5	2107B-CA_ _ _	2107B-CD_ _ _	
3	15-25	20-30	30-50	30-50	2.5	2107B-DA_ _ _	2107B-DD_ _ _	
4	30-40	40-50	60-75	60-100	4.0	2107B-EA_ _ _	2107B-ED_ _ _	
5	50-75	60-100	100-150	125-200	6.0 <sup>[2]</sup> , 20"W	2107B-FA_ _ _	2107B-FD_ _ _	PE-II

- [1] The catalog numbers listed are not complete:
- Select control voltage type from table on page 205 (e.g., 2107B-BABD).
  - Select horsepower from table on page 206 (e.g., 2107B-BABD-30).
  - Select circuit breaker type from Circuit Breaker Type table on page 211 (e.g., 2107B-BABD-30CA).
  - For circuit breaker size based on load horsepower, refer to publications 2100-TD001x-EN-P and 2100-TD002x-EN-P.
  - The catalog numbers listed include an external reset button for the overload relay. To order catalog numbers **without** the external reset button, substitute the letter "A" with the letter "K" (e.g., 2107B-BK\_ \_ \_) or replace the letter "D" with the letter "J" (e.g., 2107B-BJ\_ \_ \_).
- [2] Frame mounted unit, section does not have vertical wireway.

## Contactor and Starter Units

### Catalog Number Explanation - Space Saving NEMA Bulletin 2106 and 2107

#### Full Voltage Reversing Starters (FVR)

- Allen-Bradley Bulletin 300 starter with fused disconnect or circuit breaker
- NEMA Class 1, Type B-D unit with terminals mounted in unit
- Available with E1 Plus or E3 Plus electronic overload relay
- Space saving alternative to traditional NEMA starter units



4

41

2106		B	-	3B	A	B	-	38-24J	-	**	
2107		B	-	3B	A	B	-	38CA	-	**	
Bulletin Number	Wiring Type		NEMA Size	NEMA Enclosure Type		Control Voltage Type		Horsepower and Disconnecting Means		Option	
41A	<b>Code</b>	<b>Type</b>	41C	<b>Code</b>	<b>NEMA Size</b>	41E	<b>Code</b>	<b>Control Voltage Type</b>	41G	<b>Code</b>	<b>Option</b>
	2106	Full Voltage Reversing (FVR) with Fused Disconnect		3B	1			See Table on page 205.			See Options section beginning on page 125.
	2107	Full Voltage Reversing (FVR) with Circuit Breaker		3C	2						
				3D	3						
			41D	<b>Code</b>	<b>NEMA Enclosure Type</b>				41F	<b>Code</b>	<b>Horsepower Code and Disconnecting Means</b>
	41B	<b>Code</b>	<b>Wiring Type</b>	A	NEMA Type 1 or Type 1 with gasket with external reset button				2106 - "38-24J"		"38_" Horsepower Code. See Table on page 206. "24J" Fuse Clip Rating and Class. See Table on page 207.
		B	Type B-D	K	NEMA Type 1 or Type 1 with gasket without external reset button				2107 - "38CA"		"38_" Horsepower Code. See Table on page 206. "_CA" Circuit Breaker Type. See Table on page 211.
				D	NEMA Type 12 with external reset button						
				J	NEMA Type 12 without external reset button						

**Bulletin 2106**

*Space Saving NEMA Full Voltage Reversing Starter Unit with Fused Disconnect Switch (FVR)*

- See page 33 for product description.
- Units are cUL US listed, unless otherwise indicated.

42

NEMA Size	Horsepower		Fuse Clip (See Appendix for short circuit withstand ratings.)		Space Factor	Catalog Number <sup>[1]</sup> Wiring Type B—Class I		Delivery Program
	480V	600V	Rating (Amperes)	Class		NEMA Type 1 and Type 1 w/ gasket	NEMA Type 12	
1	0.5 - 10	0.75 - 10	30	CC, J, HRCII-C	0.5 <sup>[2]</sup>	2106B-3BA_ _ _	2106B-3BD_ _ _	SC

4

- [1] The catalog numbers listed are not complete:
- Select control voltage type from table on page 205 (e.g., 2106B-3B**ABD**).
  - Select horsepower from table on page 206 (e.g., 2106B-3B**ABD-38**).
  - Select fuse class from above. Then select clip designator from table on page 207 (e.g., 2106B-3B**ABD-38-24J**).
- The catalog numbers listed include an external reset button for the overload relay. To order catalog numbers without the external reset button, substitute the letter "A" with the letter "K" (e.g. 2106B-3B**K**\_ \_ \_) or replace the letter "D" with the letter "J" (e.g., 2106B-3B**J**\_ \_ \_).
- [2] These units have horizontal operating handles, Bulletin 194R fused disconnect, up to four (4) Bulletin 800F pilot devices, #16 AWG control wire and one (1) 10-point control terminal block (Type B-D only in Type B units). See page 8 or information on installation into series E-J sections.

**Bulletin 2107**

*Space Saving NEMA Full Voltage Reversing Starter Unit with Circuit Breaker (FVR)*

- See page 33 for product description.
- Units are cUL US listed, unless otherwise indicated.

43

NEMA Size	Horsepower		Space Factor	Catalog Number <sup>[1]</sup> Wiring Type B—Class I		Delivery Program
	480V	600V		NEMA Type 1 and Type 1 w/ gasket	NEMA Type 12	
1	0.5 - 10	0.75 - 10	0.5 <sup>[2]</sup>	2107B-3BA_ _ _	2107B-3BD_ _ _	SC
2	15 - 25	15 - 25	1.0 <sup>[3]</sup>	2107B-3CA_ _ _	2107B-3CD_ _ _	
3	30 - 50	30 - 50	1.5 <sup>[3]</sup>	2107B-3DA_ _ _	2107B-3DD_ _ _	

- [1] The catalog numbers listed are not complete:
- Select control voltage type from table on page 205 (e.g., 2107B-3B**ABD**).
  - Select horsepower from table on page 206 (e.g., 2107B-3B**ABD-38**).
  - Select circuit breaker type from Circuit Breaker Type table on page 211 (e.g., 2107B-3B**ABD-38CA**).
- The catalog numbers listed include an external reset button for the overload relay. To order catalog numbers **without** the external reset button, substitute the letter "A" with the letter "K" (e.g. 2107B-3B**K**\_ \_ \_) or replace the letter "D" with the letter "J" (e.g., 2107B-3B**J**\_ \_ \_).
- [2] These units have horizontal operating handles, up to four (4) Bulletin 800F pilot devices, #16 AWG control wire and one (1) 10-point control terminal block (Type B-D only in Type B units). See page 8 for information on installation into series E-J sections.
- [3] These units have horizontal operating handles, up to six (6) Bulletin 800F pilot devices, #16 AWG control wire and one (1) 10-point control terminal block (Type B-D only in Type B units). See page 8 for information on installation into series E-J sections.

## Contactor and Starter Units

### Catalog Number Explanation - Bulletin 2112, 2112 Vacuum, 2113, and 2113 Vacuum

#### Combination Full Voltage Non-Reversing Starter Units (FVNR)

- Allen-Bradley Bulletin 509 starter with a fusible disconnect or circuit breaker (Bulletin 2112 and 2113 Vacuum use Allen-Bradley Bulletin 1102C vacuum contactors)
- NEMA Class I, Type B unit with terminals mounted in the unit
- Available with eutectic alloy, E1 Plus or E3 electronic overload relays.

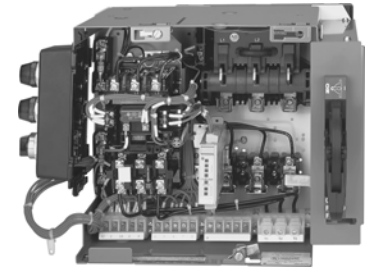

4

44

<b>2112</b>	<b>B</b>	-	<b>B</b>	<b>A</b>	<b>B</b>	-	<b>41-24J</b>	-	<b>6P</b>
<b>2113</b>	<b>B</b>	-	<b>B</b>	<b>A</b>	<b>B</b>	-	<b>41CA</b>	-	<b>6P</b>
<i>Bulletin Number</i>	<i>Wiring Type</i>		<i>NEMA Size</i>	<i>NEMA Enclosure Type</i>	<i>Control Voltage Type</i>		<i>Horsepower and Disconnecting Means</i>		<i>Options</i>

44A	
Code	Type
2112	Full Voltage Non-Reversing (FVNR) with Fusible Disconnect
2113	Full Voltage Non-Reversing (FVNR) with Circuit Breaker

44B	
Code	Wiring Type
A	Type A
B	Type B

44C	
Code	NEMA Size
Z	1 (0.5 Space Factor)
B	1
C	2
D	3
E	4
F	5
G	6

44D	
Vacuum Code	Rating
VB	200A
VC	400A
VD	600A

44E	
Code	NEMA Enclosure Type
A	NEMA Type 1 or Type 1 with gasket with external reset button
K	NEMA Type 1 or Type 1 with gasket without external reset button
D	NEMA Type 12 with external reset button
J	NEMA Type 12 without external reset button

44F	
Code	Control Voltage Type
See Table on Page 205	

44G	
Code	Fuse Clip Ratings and Class or Trip Current Circuit Breaker Type
2112 - "41-24J"	"41" Horsepower Code. See Table on Page 206 "24J" Fuse Clip Rating and Class. See Fuse Clip Designator table on page 207
2113 - "41CA"	Horsepower Code. See Table on page 206 "_CA" Circuit Breaker Type. See Circuit Breaker Type Table on page 211.

44H	
Code	Options
See Options section beginning on Page 107.	

See page 33 for product description.

NEMA Size	Horsepower				Fuse Clip (See Appendix for short circuit withstand ratings.)		Space Factor	Catalog Number <sup>[1]</sup> Wiring Type B—Class		Delivery Program
	208V	240V	380V–415V	480V/600V	Rating (Amperes)	Class		NEMA Type 1 and Type 1 w/gasket	NEMA Type 12	
1 <sup>[2]</sup>	0.125-5	0.125-5	0.125-10	0.125-10	30	CC, J, HRCII-C	0.5	2112B-ZA_ _ _	2112B-ZD_ _ _	SC
1	0.125-7.5	0.125-7.5	0.125-10	0.125-10	30	CC, J, R, H, HRCII-C,	1.0	2112B-BA_ _ _	2112B-BD_ _ _	
					60	J, R, H, HRCII-C				
2	10	10-15	15-25	15-25	30 <sup>[3]</sup>	J, R, H, HRCII-C	1.0	2112B-CA_ _ _	2112B-CD_ _ _	
					60	J, R, H, HRCII-C				
					100	R, H				
3	15-25	20-30	30-50	30-50	60 <sup>[3]</sup>	J	2.0	2112B-DA_ _ _	2112B-DD_ _ _	
					100	J				
					200	J				
4	30-40	40-50	60-75	60-100	100 <sup>[3]</sup>	J, HRCII-C	2.5	2112B-EA_ _ _	2112B-ED_ _ _	
					200	J, HRCII-C				
					400	J				
5	50-75	60-100	100-150	125-200	100 <sup>[3]</sup>	R, H, HRCII-C	3.5	2112B-FA_ _ _	2112B-FD_ _ _	
					200	R, H, HRCII-C				
					400	R, H, HRCII-C				
6 <sup>[4]</sup>	100-150	125-200	200-300	250-400	400 <sup>[3]</sup>	R, H	6.0 <sup>[5]</sup> 25" W	2112BB-GA_ _ _	2112BB-GD_ _ _	
					600	J, R, HRCII-C				
					800	L				
6 <sup>[4]</sup>	100-150	125-200	200-300	250-400	400 <sup>[3]</sup>	R, H	6.0 <sup>[5]</sup> 25" W	2112BT-GA_ _ _	2112BT-GD_ _ _	
					600	J, R, HRCII-C				
					800	L				

[1] The catalog numbers listed are not complete:

- Select control voltage type from table on page 205 (e.g., 2112B-BABD).
- Select horsepower from table on page 206 (e.g., 2112B-BABD-31).
- If power fuse will NOT be selected, select fuse clip from table above. Then select clip designator from table on page 207 (e.g., 2112B-BABD-31-24J).
- If power fuse WILL be selected, first select clip designator from table on page 207 (e.g., 2112B-BABD-31-20J). Then select power fuse from table on page 207 (e.g., 2112B-BABD-31GT-20J).
- For fuse rating based on load horsepower, see publication 2100-TD003x-EN-P.

The catalog numbers listed include an external reset button for the overload relay. To order catalog numbers **without** the external reset button, replace the letter "A" with the letter "K" (e.g., 2112B-BK\_ \_ \_) or replace the letter "D" with the letter "J" (e.g., 2112B-BJ\_ \_ \_).

[2] Separate or transformer control only, except 208V (where separate control only). These units have horizontal operating handles, Bulletin 194R fused disconnect switch, up to four (4) Bulletin 800F pilot devices and one (1) 10-pt. pull-apart control terminal block (Type B-D only in Type B units), with #16 AWG control wire only. See page 8 for information on installation into series E-J sections.

[3] Available on 480 and 600 Volt applications only.

[4] For NEMA size 6, select either top cable entry (2112BT-) or bottom cable entry (2112BB-).

[5] Frame mounted unit, section does not have vertical wireway.

## Contactor and Starter Units

### Bulletin 2112 Vacuum

#### Full Voltage Non-Reversing Starter Unit with Vacuum Contactor and Fusible Disconnect Switch (FVNR)

- See page 33 for product description.
- Starters are supplied with one (1) normally open and one (1) normally closed auxiliary contacts as standard.  
Note: option code 91 is required to indicate the normally closed contact is being supplied.  
Additional auxiliary contacts (two [2] normally open and two [2] normally closed) can be added (option code 90011)  
With optional auxiliary contacts, the complete option code (including the standard normally closed contact) is 900111.  
Refer to Options section on page 124.
- Units are NOT UL listed or CSA certified

4

45A

Rating (Amperes)	Horsepower					Space Factor	Disconnect Switch Rating (Amperes)	Fuse Clip (See Appendix for short circuit withstand ratings.)		Catalog Number <sup>[1]</sup> Wiring Type B—Class		Delivery Program
	208V	240V	380V– 415V	480V	600V			Rating (Amperes)	Fuse Class	NEMA Type 1 and Type 1 w/ gasket	NEMA Type 12	
200	40 - 50	40 - 60	60 - 100	60 - 125	60 - 150	3.5	200	100 <sup>[2]</sup>	J, R, H, HRCII-C	2112B-VBA_ -__	2112B-VBD_ -__	SC
								200	J, R, H, HRCII-C			
								400	J			
	60	75	-	150	200	4	400	200 <sup>[2]</sup>	J, R, H, HRCII-C			
								400	J			
400	75 - 100	100	125 - 200	200	250 - 300	4.5	400	200 <sup>[2]</sup>	J, R, H, HRCII-C	2112B-VCA_ -__	2112B-VCD_ -__	SC-II
								400	J, R, H, HRCII-C			
								600	J			
	125	125 - 150	250	250 - 300	350 - 400	6.0 20"W <sup>[3]</sup>	600	400	J, R, H, HRCII-C			
								600	J			
600	150	-	300	350	-	6.0 20"W <sup>[3]</sup>	600	400	J, R, H, HRCII-C	2112B-VDA_ -__	2112B-VDD_ -__	
								600	J			

[1] The catalog numbers listed are not complete:

- Select the control voltage type from table on page 205 (e.g., 2112B-VBABD).
- Select the horsepower from table on page 206 (e.g., 2112B-VBABD-51).
- If power fuse will NOT be selected, select fuse clip from table above. Then select clip designator from table on page 207 (e.g., 2112B-VBABD-51-26J).
- If power fuse WILL be selected, first select clip designator from table on page 207 (e.g., 2112B-VBABD-51-20J).  
Then select power fuse from table on page 207 (e.g., 2112B-VBABD-51GT-20J).
- For fuse rating based on load horsepower, see publication 2100-TD003x-EN-P.

The catalog numbers listed include an external reset button for the overload relay. To order catalog numbers without the external reset button, replace the letter "A" with the letter "K" (e.g., 2112B-VBK\_ -\_\_ ) or replace the letter "D" with the letter "J" (e.g., 2112B-VBJ\_ -\_\_ ).

[2] Available on 480 and 600 Volt applications only.

[3] Frame mounted unit, section does not have vertical wireway.

See page 33 for product description.

46

NEMA Size	Horsepower				Space Factor	Catalog Number <sup>[1]</sup> Wiring Type B—Class I		Delivery Program
	208V	240V	380V–415V	480V/600V		NEMA Type 1 and Type 1 w/ gasket	NEMA Type 12	
1 <sup>[2]</sup>	0.125-5	0.125-5	0.125-10	0.125-10	0.5	2113B-ZA_ _ _	2113B-ZD_ _ _	SC
1	0.125-7.5	0.125-7.5	0.125-10	0.125-10	1.0	2113B-BA_ _ _	2113B-BD_ _ _	
DUAL 1 <sup>[3]</sup>	0.125-7.5	0.125-7.5	0.125-10	0.125-10	1.5	2113B-BA_ _ _ <sup>[4]</sup>	2113B-BD_ _ _ <sup>[4]</sup>	
2	10	10-15	15-25	15-25	1.0	2113B-CA_ _ _	2113B-CD_ _ _	
DUAL 2 <sup>[3]</sup>	10	10-15	15-25	15-25	1.5	2113B-CA_ _ _ <sup>[4]</sup>	2113B-CD_ _ _ <sup>[4]</sup>	
3	15-25	20-30	30-50	30-50	1.5	2113B-DA_ _ _	2113B-DD_ _ _	
4	30-40	40-50	60-75	60-100	2.0	2113B-EA_ _ _	2113B-ED_ _ _	
5	50-75	60-100	100-150	125-200	3.5	2113B-FA_ _ _	2113B-FD_ _ _	
6 <sup>[5]</sup>	100-150	125-200	200-300	250-400	6.0 <sup>[6]</sup>	2113BT-GA_ _ _	2113BT-GD_ _ _	PE-II
					25" W	2113BB-GA_ _ _	2113BB-GD_ _ _	

4

- [1] The catalog numbers listed are not complete:
  - Select the control voltage type from table on page 205 (e.g., 2113B-BABD).
  - Select horsepower from table on page 206 (e.g., 2113B-BABD-30).
  - Select circuit breaker from Circuit Breaker Type table on page 211 (e.g., 2113B-BABD-30CA).
  - For circuit breaker size based on load horsepower, refer to publications 2100-TD001x-EN-P and 2100-TD002x-EN-P.
 The catalog numbers listed include an external reset button for the overload relay. To order catalog numbers **without** the external reset button, replace the letter "A" with the letter "K" (e.g., 2113B-BK\_ \_ \_) or replace the letter "D" with the letter "J" (e.g., 2113B-BJ\_ \_ \_).
- [2] Separate or transformer control only, except 208V (where separate control only). These units have horizontal operating handles, up to four (4) Bulletin 800F pilot devices and one (1) 10-pt. pull-apart control terminal block (Type BD only in Type B units), with #16 AWG control wire only. See page 8 for information on installation into series E-J sections.
- [3] Dual mounted units supplied without power terminal blocks.
- [4] Dual mounting of combination starters in one unit. Add two numbers from table on page 206 to identify the horsepower and add the suffix letter from table on page 211 to identify the circuit breaker type (e.g., 2113B-BABD-3941CA).
- [5] For 200HP at 240V or 400HP at 480V, suffix letter identifying circuit breaker must be **CT** or **CM** only. For NEMA size 6, select either top cable entry (2113BT-) or bottom entry (2113BB-) of motor load cables.
- [6] Frame mounted unit, section does not have vertical wireway.

Bulletin 2113 Vacuum

Full Voltage Non-Reversing Starter Unit with Vacuum Contactor and Circuit Breaker (FVNR)

- See page 33 for product description.
- Starters are supplied with one (1) normally open and one (1) normally closed auxiliary contacts as standard.
  - Note: option code 91 is required to indicate the normally closed contact is being supplied.
  - Additional auxiliary contacts (two [2] normally open and two [2] normally closed) can be added (option code 90011)
  - With optional auxiliary contacts, the complete option code (including the standard normally closed contact) is 900111.
  - Refer to Options section on page 120.
- Units are NOT UL listed or CSA certified

46A

Rating (Amperes)	Horsepower					Space Factor	Circuit Breaker Frame (Amperes)	Catalog Number <sup>[1]</sup> Wiring Type B—Class		Delivery Program
	208V	240V	380V–415V	480V	600V			NEMA Type 1 and Type 1 w/ gasket	NEMA Type 12	
200	40	40 - 50	60 - 75	60 - 100	60 - 100	3.5	250AF	2113B-VBA_ _ _	2113B-VBD_ _ _	SC
	50 - 60	60 - 75	100	125 - 150	125 - 200					
400	-	-	125	-	-	3.5	250AF	2113B-VCA_ _ _	2113B-VCD_ _ _	
	75	100	150	200	-	3.5	400AF	2113B-VCA_ _ _	2113B-VCD_ _ _	
	100	-	200	-	250 - 300	4	600AF	2113B-VCA_ _ _	2113B-VCD_ _ _	
600	125	125 - 150	250	250 - 300	350 - 400	6.0, 20"W <sup>[2]</sup>	600AF	2113B-VCA_ _ _	2113B-VCD_ _ _	SC-II
	150	-	300	350	-	6.0, 20"W <sup>[2]</sup>	600AF	2113B-VDA_ _ _	2113B-VDD_ _ _	

- [1] The catalog numbers listed are not complete:
  - Select the control voltage type from table on page 205 (e.g., 2113B-VBABD).
  - Select the horsepower from table on page 206 (e.g., 2113B-VBABD-52).
  - Select the circuit breaker from Circuit Breaker Type table on page 211 (e.g., 2113B-VBABD-52CT).
  - For circuit breaker size based on load horsepower, refer to publications 2100-TD001x-EN-P and 2100-TD002x-EN-P.
  - The catalog numbers listed include an external reset button for the overload relay. To order catalog numbers without the external reset button, replace the letter "A" with the letter "K" (e.g., 2113B-VBK\_ \_ \_) or replace the letter "D" with the letter "J" (e.g., 2113B-VBJ\_ \_ \_).
- [2] Frame mounted unit, section does not have vertical wireway.

Catalog Number Explanation - Space Saving NEMA Bulletin 2112 and 2113

Full Voltage Non-Reversing Starters (FVNR)

- Allen-Bradley Bulletin 300 starter with fused disconnect or circuit breaker
- NEMA Class 1, Type B unit with terminals mounted in unit
- Available with E1 Plus or E3 electronic overload relay
- Space saving alternative to traditional NEMA starter units

4

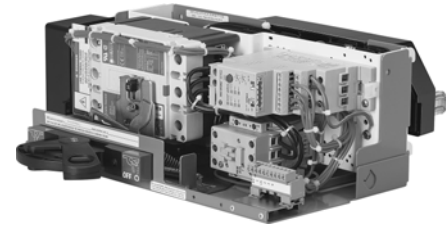

47

<b>2112</b>	<b>B</b>	-	<b>3B</b>	<b>A</b>	<b>B</b>	-	<b>38-24J</b>	-	<b>**</b>
<b>2113</b>	<b>B</b>	-	<b>3B</b>	<b>A</b>	<b>B</b>	-	<b>38CA</b>	-	<b>**</b>
<i>Bulletin Number</i>	<i>Wiring Type</i>		<i>NEMA Size</i>	<i>NEMA Enclosure Type</i>	<i>Control Voltage Type</i>		<i>Horsepower and Disconnecting Means</i>		<i>Option</i>
47A			47C		47E		47G		
<b>Code</b>	<b>Type</b>		<b>Code</b>	<b>NEMA Size</b>	<b>Code</b>	<b>Control Voltage Type</b>	<b>Code</b>	<b>Option</b>	
2112	Full Voltage Non-Reversing (FVNR) with Fused Disconnect		3B	1	See Table on page 205.			See Options section beginning on page 125.	
2113	Full Voltage Non-Reversing (FVNR) with Circuit Breaker		3C	2					
			3D	3					
			3E	4					
			47D				47F		
			<b>Code</b>	<b>NEMA Enclosure Type</b>			<b>Code</b>	<b>Horsepower Code and Disconnecting Means</b>	
47B	<b>Code</b>	<b>Wiring Type</b>	A	NEMA Type 1 or Type 1 with gasket with external reset button			2112 - "38-24J"	"38" Horsepower Code. See Table on page 206. "24J" Fuse Clip Rating and Class. See Table on page 207.	
	B	Type B-D	K	NEMA Type 1 or Type 1 with gasket without external reset button			2113 - "38CA"	"38_" Horsepower Code. See Table on page 206. "_CA" Circuit Breaker Type. See Table on page 211.	
			D	NEMA Type 12 with external reset button					
			J	NEMA Type 12 without external reset button					

**Bulletin 2112**

*Space Saving NEMA Full Voltage Non-Reversing Starter Unit with Fused Disconnect Switch (FVNR)*

- See page 34 for product description.
- Units are cUL US listed unless otherwise indicated.

48

**4**

NEMA Size	Horsepower		Fuse Clip (See Appendix for short circuit withstand ratings.)		Space Factor	Catalog Number <sup>[1]</sup> Wiring Type B—Class I		Delivery Program
	480V	600V	Rating (Amperes)	Class		NEMA Type 1 and Type 1 w/ gasket	NEMA Type 12	
1	0.5 - 10	0.75 - 10	30	CC, J, HRCII-C	0.5 <sup>[2]</sup>	2112B-3BA_ _	2112B-3BD_ _	SC

- [1] The catalog numbers listed are not complete:
- Select control voltage type from table on page 205 (e.g., 2112B-3B**ABD**).
  - Select horsepower from table on page 206 (e.g., 2112B-3B**ABD-38**).
  - Select fuse class from above. Then select clip designator from table on page 207 (e.g., 2112B-3B**ABD-38-24J**).  
The catalog numbers listed include an external reset button for the overload relay. To order catalog numbers without the external reset button, substitute the letter "A" with the letter "K" (e.g. 2112B-3BK\_ \_) or replace the letter "D" with the letter "J" (e.g., 2112B-3BJ\_ \_).
- [2] These units have horizontal operating handles, Bulletin 194R fused disconnect, up to four (4) Bulletin 800F pilot devices, #16 AWG control wire and one (1) 10-point control terminal block (Type B-D only in Type B units). See page 8 for information on installation into series E-J sections.

**Bulletin 2113**

*Space Saving NEMA Full Voltage Non-Reversing Starter Unit with Circuit Breaker (FVNR)*

- See page 34 for product description.
- Units are cUL US listed unless otherwise indicated.

49

NEMA Size	Horsepower		Space Factor	Catalog Number <sup>[1]</sup> Wiring Type B—Class I		Delivery Program
	480V	600V		NEMA Type 1 and Type 1 w/ gasket	NEMA Type 12	
1	0.5 - 10	0.75 - 10	0.5 <sup>[2]</sup>	2113B-3BA_ _	2113B-3BD_ _	SC
2	15 - 25	15 - 25	0.5 <sup>[2],[3]</sup>	2113B-3CA_ _	2113B-3CD_ _	
3	30 - 50	30 - 50	1.0 <sup>[4]</sup>	2113B-3DA_ _	2113B-3DD_ _	
4	60 - 100	60 - 100	1.0 <sup>[4],[5]</sup>	2113B-3EA_ _	2113B-3ED_ _	

- [1] The catalog numbers listed are not complete:
- Select control voltage type from table on page 205 (e.g., 2113B-3B**ABD**).
  - Select horsepower from table on page 206 (e.g., 2113B-3B**ABD-38**).
  - Select circuit breaker type from Circuit Breaker Type table on page 211 (e.g., 2113B-3B**ABD-38CA**).  
The catalog numbers listed include an external reset button for the overload relay. To order catalog numbers **without** the external reset button, substitute the letter "A" with the letter "K" (e.g. 2113B-3BK\_ \_) or replace the letter "D" with the letter "J" (e.g., 2113B-3BJ\_ \_).
- [2] These units have horizontal operating handles, up to four (4) Bulletin 800F pilot devices, #16AWG control wire and one (1) 10-point control terminal block (Type B-D only in Type B units). See page 8 for information on installation into series E-J sections.
- [3] 1.0 space factor required for Size 2, Bulletin 2113 units with pilot devices and external reset button for overload relay.
- [4] These units have horizontal operating handles, up to six (6) Bulletin 800F pilot devices, #16 AWG control wire and one (1) 10-point control terminal block (Type B-D only in Type B units). See page 8 for information on installation into series E-J sections.
- [5] 1.0 space factor for unit with E1 Plus overload relay (option 7FEE\_ , 7FEE\_D, or 7FEE\_J)  
1.5 space factor for unit with E3 overload relay (option 7FEC1\_ or 7FEC2\_)

## Contactors and Starter Units

### Catalog Number Explanation - Bulletin 2122E, 2123E, 2122F and 2123F Combination 2-Speed Starter Units (TS2W and TS1W)

- Allen-Bradley Bulletin 520 starter with a fusible disconnect or circuit breaker
- Designed with separate windings or consequent pole windings
- NEMA Class I, Type B wiring with terminals mounted in the unit
- Two-Speed units available with eutectic alloy or E1 Plus overload relays
- NEMA Sizes 1 - 5



4

50

2122E		B	-	B	A	B	-	41-24J	-	6P		
2123F		B	-	B	A	B	-	41CA	-	6P		
Bulletin Number	Wiring Type			NEMA Size	NEMA Enclosure Type	Control Voltage Type		Horsepower and Disconnecting Means		Option		
50A	<b>Code</b>	<b>Type</b>		50C	<b>Code</b>	<b>NEMA Size</b>	50E	<b>Code</b>	<b>Control Voltage Type</b>	50G	<b>Code</b>	<b>Option</b>
	2122E	Two-Speed, 2-Winding Starter (TS2W) with Fusible Disconnect		B	1			See Table on Page 205			See Options section beginning on Page 107.	
	2123E	Two-Speed, 2-Winding (TS2W) with Circuit Breaker		C	2							
	2122F	Two-Speed, 1-Winding Starter (TS1W) with Fusible Disconnect		D	3							
	2123F	Two-Speed, 1-Winding (TS1W) with Circuit Breaker		E	4							
				F	5							
				50D	<b>Code</b>	<b>NEMA Enclosure Type</b>						
				A		NEMA Type 1 or Type 1 with gasket with external reset button						
				K		NEMA Type 1 or Type 1 with gasket without external reset button						
				D		NEMA Type 12 with external reset button						
				J		NEMA Type 12 without external reset button						
	50B	<b>Code</b>	<b>Wiring Type</b>									
		A	Type A									
		B	Type B									
				50F	<b>Code</b>	<b>Fuse Clip Ratings and Class or Trip Current Circuit Breaker Type</b>						
					2122 - "41-24J"	"41" Horsepower Code. See Table on Page 206 "24J" Fuse Clip Rating and Class. See Fuse Clip Designator table on page 207						
					2123 - "41CA"	Horsepower Code. See Table on page 206 "_CA" Circuit Breaker Type. See Circuit Breaker Type Table on page 211.						

- See page 34 for product description.
- Unit includes one set of 3-pole fuse clips.

**NOTE:** A two-speed 2-winding motor (TS2W) requires a mechanically and electrically interlocked assembly of two 3-pole contactors. A two-speed 1-winding motor (TS1W) requires a mechanically and electrically interlocked assembly of 3-pole and 5-pole contactors. Consult your local Rockwell Automation Sales Office for application assistance.

51

NEMA Size	Constant or Variable Torque Horsepower				Fuse Clip (See Appendix for short circuit withstand ratings.)		Space Factor	Catalog Number <sup>[1]</sup> Wiring Type B—Class I		Delivery Program	
	208V	240V	380V–415V	480V/600V	Rating (Amperes)	Class		NEMA Type 1 and Type 1 w/ gasket	NEMA Type 12		
1	0.125-7.5	0.125- 7.5	0.125-10	0.125-10	30	CC, J, R, H, HRCII-C	2.0	2122EB-BA_ _ _	2122EB-BD_ _ _	SC	
					60	J, R, H, HRCII-C					
2	10	10-15	15-25	15-25	30 <sup>[2]</sup>	J, R, H, HRCII-C	2.0	2122EB-CA_ _ _	2122EB-CD_ _ _		
					60	J, R, H, HRCII-C					
					100	J, R, H, HRCII-C					
3	15-25	20-30	30-50	30-50	60 <sup>[2]</sup>	J, R, H, HRCII-C	3.0	2122EB-DA_ _ _	2122EB-DD_ _ _		
					100	J, R, H, HRCII-C					
					200	J, R, H, HRCII-C					
4	30-40	40-50	60-75	60-100	100 <sup>[2]</sup>	J, R, H, HRCII-C	4.5	2122EB-EA_ _ _	2122EB-ED_ _ _		PE
					200	J, R, H, HRCII-C					
					400	J					
5 <sup>[3]</sup>	50-75	60-100	100-150	125-200	200 <sup>[2]</sup>	J, R, H, HRCII-C	6.0 <sup>[4]</sup> , 20" W	2122EB-FA_ _ _	2122EB-FD_ _ _	PE-II	
400	J, R, H, HRCII-C										
600	J										

[1] The catalog numbers listed are not complete:

- Select the control voltage type from table on page 205 (e.g., 2122EB-BABD).
- Select horsepower from table on page 206 (e.g., 2122EB-BABD-31).
- If power fuse will NOT be selected, select fuse clip from table above. Then select clip designator from table on page 207 (e.g., 2122EB-BABD-31-24J).
- If power fuse WILL be selected, first select clip designator from table on page 207 (e.g., 2122EB-BABD-31-20J). Then select power fuse from table on page 207 (e.g., 2122EB-BABD-31GT-20J).
- For fuse rating based on load horsepower, see publication 2100-TD003x-EN-P.

The catalog numbers listed include an external reset button for the overload relay. To order catalog numbers **without** the external reset button, replace the letter "A" with the letter "K" (e.g., 2122EB-BK\_ \_ \_) or replace the letter "D" with the letter "J" (e.g., 2122EB-BJ\_ \_ \_).

[2] Available on 480 and 600 Volt applications only.

[3] If low speed full load current is below 77A, a special starter is required. Contact your local Rockwell Automation Sales Office.

[4] Frame mounted unit, section does not have vertical wireway.

## Contactor and Starter Units

### Bulletin 2122F

#### Two Speed 1-Winding Starter Unit with Fusible Disconnect Switch (TS1W)

- See page 34 for product description.
- Unit includes one set of 3-pole fuse clips.

**NOTE:** A two-speed 1-winding motor (TS1W) requires a mechanically and electrically interlocked assembly of 3-pole and 5-pole contactors. A two-speed 2-winding motor (TS2W) requires a mechanically and electrically interlocked assembly of two 3-pole contactors. Consult your local Rockwell Automation Sales Office for application assistance.

4

52

NEMA Size	Constant or Variable Torque Horsepower				Fuse Clip (See Appendix for short circuit withstand ratings.)		Space Factor	Catalog Number <sup>[1]</sup> Wiring Type B—Class I		Delivery Program
	208V	240V	380V- 415V	480V/600V	Rating (Amperes)	Class		NEMA Type 1 and Type 1 w/ gasket	NEMA Type 12	
1	0.125-7.5	0.125-7.5	0.125-10	0.125-10	30 60	CC, J, R, H, HRCII-C J, R, H, HRCII-C	2.0	2122FB-BA_ _	2122FB-BD_ _	SC
2	10	10-15	15-25	15-25	30 <sup>[2]</sup> 60 100	J, R, H, HRCII-C J, R, H, HRCII-C J, R, H, HRCII-C	2.0	2122FB-CA_ _	2122FB-CD_ _	
3	15-25	20-30	30-50	30-50	60 <sup>[2]</sup> 100 200	J, R, H, HRCII-C J, R, H, HRCII-C J, R, H, HRCII-C	4.0	2122FB-DA_ _	2122FB-DD_ _	
4	30-40	40-50	60-75	60-100	100 <sup>[2]</sup> 200 400	J, R, H, HRCII-C J, R, H, HRCII-C J	4.5	2122FB-EA_ _	2122FB-ED_ _	PE
5 <sup>[3]</sup>	50-75	60-100	100-150	125-200	200 <sup>[2]</sup> 400 600	J, R, H, HRCII-C J, R, H, HRCII-C J	6.0 <sup>[4]</sup> 25" W	2122FB-FA_ _	2122FB-FD_ _	PE-II

[1] The catalog numbers listed are not complete:

- Select the control voltage type from table on page 205 (e.g., 2122FB-BABD).
- Select the horsepower from table on page 206 (e.g., 2122FB-BABD-31).
- If power fuse will NOT be selected, select fuse clip from table above. Then select clip designator from table on page 207 (e.g., 2122FB-BABD-31-24J).
- If power fuse WILL be selected, first select clip designator from table on page 207 (e.g., 2122FB-BABD-31-20J). Then select power fuse from table on page 207 (e.g., 2122FB-BABD-31GT-20J).
- For fuse rating based on load horsepower, see publication 2100-TD003x-EN-P.

The catalog numbers listed include an external reset button for the overload relay. To order catalog numbers **without** the external reset button, replace the letter "A" with the letter "K" (e.g., 2122FB-BK\_ \_) or replace the letter "D" with the letter "J" (e.g., 2122FB-BJ\_ \_).

[2] Available on 480 and 600 Volt applications only.

[3] If low speed full load current is below 77A, a special starter is required. Contact your local Rockwell Automation Sales Office.

[4] Frame mounted unit, section does not have vertical wireway.

See page 34 for product description.

**NOTE:** A two-speed 2-winding motor (TS2W) requires a mechanically and electrically interlocked assembly of two 3-pole contactors. A two-speed 1-winding motor (TS1W) requires a mechanically and electrically interlocked assembly of 3-pole and 5-pole contactors. Consult your local Rockwell Automation Sales Office for application assistance.

NEMA Size	Constant or Variable Torque Horsepower				Space Factor	Catalog Number <sup>[1]</sup> Wiring Type B—Class I		Delivery Program
	208V	240V	380V-415V	480V/600V		NEMA Type 1 and Type 1 w/ gasket	NEMA Type 12	
1	0.125-7.5	0.125-7.5	0.125-10	0.125-10	2.0	2123EB-BA_ _	2123EB-BD_ _	SC
2	10	10-15	15-25	15-25	2.0	2123EB-CA_ _	2123EB-CD_ _	
3	15-25	20-30	30-50	30-50	3.0	2123EB-DA_ _	2123EB-DD_ _	
4	30-40	40-50	60-75	60-100	4.5	2123EB-EA_ _	2123EB-ED_ _	PE
5 <sup>[2]</sup>	50-75	60-100	100-150	125-200	6.0 <sup>[3]</sup> , 20" W	2123EB-FA_ _	2123EB-FD_ _	PE-II

- [1] The catalog numbers listed are not complete:
- Select the control voltage type from table on page 205 (e.g., 2123EB-BABD).
  - Select the horsepower from table on page 206 (e.g., 2123EB-BABD-30).
  - Select the circuit breaker from Circuit Breaker Type table on page 211 (e.g., 2123EB-BABD-30CA).
  - For circuit breaker size based on load horsepower, refer to publications 2100-TD001x-EN-P and 2100-TD002x-EN-P.
- The catalog numbers listed include an external reset button for the overload relay. To order catalog numbers **without** the external reset button, replace the letter "A" with the letter "K" (e.g., 2123EB-BK\_ \_) or replace the letter "D" with the letter "J" (e.g., 2123EB-BJ\_ \_).
- [2] If low speed full load current is below 77A, a special starter is required. Contact your local Rockwell Automation Sales Office.
- [3] Frame mounted unit, section does not have vertical wireway.

See page 34 for product description.

**NOTE:** A two-speed 1-winding motor (TS1W) requires a mechanically and electrically interlocked assembly of 3-pole and 5-pole contactors. A two-speed 2-winding motor (TS2W) requires a mechanically and electrically interlocked assembly of two 3-pole contactors. Consult your local Rockwell Automation Sales Office for application assistance.

NEMA Size	Constant or Variable Torque Horsepower				Space Factor	Catalog Number <sup>[1]</sup> Wiring Type B—Class I		Delivery Program
	208V	240V	380V-415V	480V/600V		NEMA Type 1 and Type 1 w/ gasket	NEMA Type 12	
1	0.125-7.5	0.125-7.5	0.125-10	0.125-10	2.0	2123FB-BA_ _	2123FB-BD_ _	SC
2	10	10-15	15-25	15-25	2.0	2123FB-CA_ _	2123FB-CD_ _	
3	15-25	20-30	30-50	30-50	3.5	2123FB-DA_ _	2123FB-DD_ _	
4	30-40	40-50	60-75	60-100	4.5	2123FB-EA_ _	2123FB-ED_ _	PE
5 <sup>[2]</sup>	50-75	60-100	100-150	125-200	6.0 <sup>[3]</sup> , 25" W	2123FB-FA_ _	2123FB-FD_ _	PE-II

- [1] The catalog numbers listed are not complete:
- Select the control voltage type from table on page 205 (e.g., 2123FB-BABD).
  - Select the horsepower from table on page 206 (e.g., 2123FB-BABD-30).
  - Select the circuit breaker from Circuit Breaker Type table on page 211 (e.g., 2123FB-BABD-30CA).
  - For circuit breaker size based on load horsepower, refer to publications 2100-TD001x-EN-P and 2100-TD002x-EN-P.
- The catalog numbers listed include an external reset button for the overload relay. To order catalog numbers **without** the external reset button, replace the letter "A" with the letter "K" (e.g., 2123FB-BK\_ \_) or replace the letter "D" with the letter "J" (e.g., 2123FB-BJ\_ \_).
- [2] If low speed full load current is below 77A, a special starter is required. Contact your local Rockwell Automation Sales Office.
- [3] Frame mounted unit, section does not have vertical wireway.

## Contactors and Starter Units

### Catalog Number Explanation - Bulletin 2126E, 2127E, 2126F, 2127F, 2126J, 2127J, 2126K and 2127K

#### Combination 2-Speed Reversing Starter Units (TSR2W and TSR1W)

4

- Allen-Bradley Bulletin 505, Reversing and Bulletin 520, 2-speed starter with a fusible disconnect or circuit breaker
- Designed with separate windings or consequent pole windings
- NEMA sizes 1 and 2
- NEMA Class I, Type B wiring with terminals mounted in the unit
- Two-Speed, Reversing units available with eutectic alloy or E1 Plus overload relays

55

2126E		B	-	B	A	B	-	41-24J	-	6P																																
2127E		B	-	B	A	A	-	41CA	-	6P																																
Bulletin Number	Wiring Type		NEMA Size	NEMA Enclosure Type	Control Voltage Type		Horsepower and Disconnecting Means	Option																																		
55B		55C		55E		55G																																				
<table border="1"> <thead> <tr> <th>Code</th> <th>Wiring Type</th> </tr> </thead> <tbody> <tr> <td>A</td> <td>Type A</td> </tr> <tr> <td>B</td> <td>Type B</td> </tr> </tbody> </table>		Code	Wiring Type	A	Type A	B	Type B	<table border="1"> <thead> <tr> <th>Code</th> <th>NEMA Size</th> </tr> </thead> <tbody> <tr> <td>B</td> <td>1</td> </tr> <tr> <td>C</td> <td>2</td> </tr> </tbody> </table>		Code	NEMA Size	B	1	C	2	<table border="1"> <thead> <tr> <th>Code</th> <th>Control Voltage Type</th> </tr> </thead> <tbody> <tr> <td colspan="2">See Table on Page 205</td> </tr> </tbody> </table>		Code	Control Voltage Type	See Table on Page 205		<table border="1"> <thead> <tr> <th>Code</th> <th>Option</th> </tr> </thead> <tbody> <tr> <td colspan="2">See Options section beginning on Page 107.</td> </tr> </tbody> </table>		Code	Option	See Options section beginning on Page 107.																
Code	Wiring Type																																									
A	Type A																																									
B	Type B																																									
Code	NEMA Size																																									
B	1																																									
C	2																																									
Code	Control Voltage Type																																									
See Table on Page 205																																										
Code	Option																																									
See Options section beginning on Page 107.																																										
55A		55D		55F																																						
<table border="1"> <thead> <tr> <th>Code</th> <th>Type</th> </tr> </thead> <tbody> <tr> <td>2126E</td> <td>Two-Speed, Reversing 2-Winding Starter (TSR2W) with Fusible Disconnect</td> </tr> <tr> <td>2127E</td> <td>Two-Speed, Reversing 2-Winding Starter (TSR2W) with Circuit Breaker</td> </tr> <tr> <td>2126F</td> <td>Two-Speed, Reversing 1-Winding Starter (TSR1W) with Fusible Disconnect</td> </tr> <tr> <td>2127F</td> <td>Two-Speed, Reversing 1-Winding Starter (TSR1W) with Circuit Breaker</td> </tr> <tr> <td>2126J</td> <td>Two-Speed, Reversing in Low Speed Only 2-Winding Starter (TSR2W) with Fusible Disconnect</td> </tr> <tr> <td>2127J</td> <td>Two-Speed, Reversing in Low Speed Only 2-Winding Starter (TSR2W) with Circuit Breaker</td> </tr> <tr> <td>2126K</td> <td>Two-Speed, Reversing in Low Speed Only 1-Winding Starter (TSR1W) with Fusible Disconnect</td> </tr> <tr> <td>2127K</td> <td>Two-Speed, Reversing in Low Speed Only 1-Winding Starter (TSR1W) with Circuit Breaker</td> </tr> </tbody> </table>		Code	Type	2126E	Two-Speed, Reversing 2-Winding Starter (TSR2W) with Fusible Disconnect	2127E	Two-Speed, Reversing 2-Winding Starter (TSR2W) with Circuit Breaker	2126F	Two-Speed, Reversing 1-Winding Starter (TSR1W) with Fusible Disconnect	2127F	Two-Speed, Reversing 1-Winding Starter (TSR1W) with Circuit Breaker	2126J	Two-Speed, Reversing in Low Speed Only 2-Winding Starter (TSR2W) with Fusible Disconnect	2127J	Two-Speed, Reversing in Low Speed Only 2-Winding Starter (TSR2W) with Circuit Breaker	2126K	Two-Speed, Reversing in Low Speed Only 1-Winding Starter (TSR1W) with Fusible Disconnect	2127K	Two-Speed, Reversing in Low Speed Only 1-Winding Starter (TSR1W) with Circuit Breaker	<table border="1"> <thead> <tr> <th>Code</th> <th>NEMA Enclosure Type</th> </tr> </thead> <tbody> <tr> <td>A</td> <td>NEMA Type 1 or Type 1 with gasket with external reset button</td> </tr> <tr> <td>K</td> <td>NEMA Type 1 or Type 1 with gasket without external reset button</td> </tr> <tr> <td>D</td> <td>NEMA Type 12 with external reset button</td> </tr> <tr> <td>J</td> <td>NEMA Type 12 without external reset button</td> </tr> </tbody> </table>		Code	NEMA Enclosure Type	A	NEMA Type 1 or Type 1 with gasket with external reset button	K	NEMA Type 1 or Type 1 with gasket without external reset button	D	NEMA Type 12 with external reset button	J	NEMA Type 12 without external reset button	<table border="1"> <thead> <tr> <th>Code</th> <th>Fuse Clip Ratings and Class or Trip Current Circuit Breaker Type</th> </tr> </thead> <tbody> <tr> <td>2126 - "41-24J"</td> <td>"41" Horsepower Code. See Horsepower Table on page 206. "24J" Fuse Clip Rating and Class. See Fuse Clip Designator table on page 207.</td> </tr> <tr> <td>2127 - "41CA"</td> <td>"41_" Horsepower Code. See Horsepower Table on page 206. "_CA" Circuit Breaker Type. See Circuit Breaker Type Table on page 211.</td> </tr> </tbody> </table>		Code	Fuse Clip Ratings and Class or Trip Current Circuit Breaker Type	2126 - "41-24J"	"41" Horsepower Code. See Horsepower Table on page 206. "24J" Fuse Clip Rating and Class. See Fuse Clip Designator table on page 207.	2127 - "41CA"	"41_" Horsepower Code. See Horsepower Table on page 206. "_CA" Circuit Breaker Type. See Circuit Breaker Type Table on page 211.			
Code	Type																																									
2126E	Two-Speed, Reversing 2-Winding Starter (TSR2W) with Fusible Disconnect																																									
2127E	Two-Speed, Reversing 2-Winding Starter (TSR2W) with Circuit Breaker																																									
2126F	Two-Speed, Reversing 1-Winding Starter (TSR1W) with Fusible Disconnect																																									
2127F	Two-Speed, Reversing 1-Winding Starter (TSR1W) with Circuit Breaker																																									
2126J	Two-Speed, Reversing in Low Speed Only 2-Winding Starter (TSR2W) with Fusible Disconnect																																									
2127J	Two-Speed, Reversing in Low Speed Only 2-Winding Starter (TSR2W) with Circuit Breaker																																									
2126K	Two-Speed, Reversing in Low Speed Only 1-Winding Starter (TSR1W) with Fusible Disconnect																																									
2127K	Two-Speed, Reversing in Low Speed Only 1-Winding Starter (TSR1W) with Circuit Breaker																																									
Code	NEMA Enclosure Type																																									
A	NEMA Type 1 or Type 1 with gasket with external reset button																																									
K	NEMA Type 1 or Type 1 with gasket without external reset button																																									
D	NEMA Type 12 with external reset button																																									
J	NEMA Type 12 without external reset button																																									
Code	Fuse Clip Ratings and Class or Trip Current Circuit Breaker Type																																									
2126 - "41-24J"	"41" Horsepower Code. See Horsepower Table on page 206. "24J" Fuse Clip Rating and Class. See Fuse Clip Designator table on page 207.																																									
2127 - "41CA"	"41_" Horsepower Code. See Horsepower Table on page 206. "_CA" Circuit Breaker Type. See Circuit Breaker Type Table on page 211.																																									

Two Speed Reversing 2-Winding Starter Unit with Fusible Disconnect Switch (TSR2W)

- See page 34 for product description.
- Unit includes one set of 3-pole fuse clips.

**NOTE:** A two-speed 2-winding motor (TS2W) requires a mechanically and electrically interlocked assembly of two 3-pole contactors. A two-speed 1-winding motor (TS1W) requires a mechanically and electrically interlocked assembly of 3-pole and 5-pole contactors. Consult your local Rockwell Automation Sales Office for application assistance.

56

NEMA Size	Constant or Variable Torque Horsepower				Fuse Clip (See Appendix for short circuit withstand ratings.)		Space Factor	Catalog Number <sup>[1]</sup> Wiring Type B—Class I		Delivery Program
	208V	240V	380V-415V	480V/600V	Rating (Amperes)	Class		NEMA Type 1 and Type 1 w/ gasket	NEMA Type 12	
1	0.125-7.5	0.125-7.5	0.125-10	0.125-10	30	CC, J, R, H, HRCII-C	3.0	2126EB-BA_ _	2126EB-BD_ _	PE
					60	J, R, H, HRCII-C				
2	10	10-15	15-25	15-25	30 <sup>[2]</sup>	J, R, H, HRCII-C	3.0	2126EB-CA_ _	2126EB-CD_ _	
					60	J, R, H, HRCII-C				
					100	J, HRCII-C				

[1] The catalog numbers listed are not complete:

- Select control voltage type from table on page 205 (e.g., 2126EB-BABD).
- Select horsepower from table on page 206 (e.g., 2126EB-BABD-31).
- If power fuse will NOT be selected, select fuse clip from table above. Then select clip designator from table on page 207 (e.g., 2126EB-BABD-31-24J).
- If power fuse WILL be selected, first select clip designator from table on page 207 (e.g., 2126EB-BABD-31-20J). Then select power fuse from table on page 207 (e.g., 2126EB-BABD-31GT-20J).
- For fuse rating based on load horsepower, see publication 2100-TD003x-EN-P.

The catalog numbers listed include an external reset button for the overload relay. To order catalog numbers **without** the external reset button, replace the letter "A" with the letter "K" (e.g., 2126EB-BK\_ \_) or replace the letter "D" with the letter "J" (e.g., 2126EB-BJ\_ \_).

[2] Available on 480 and 600 Volt applications only.

Two Speed Reversing 1-Winding Starter Unit with Fusible Disconnect Switch (TSR1W)

- See page 34 for product description.
- Unit includes one set of 3-pole fuse clips.

**NOTE:** A two-speed 2-winding motor (TSR2W) requires a mechanically and electrically interlocked assembly of two 3-pole contactors. A two-speed 1-winding motor (TSR1W) requires a mechanically and electrically interlocked assembly of 3-pole and 5-pole contactors. Consult your local Rockwell Automation Sales Office for application assistance.

57

NEMA Size	Constant or Variable Torque Horsepower				Fuse Clip (See Appendix for short circuit withstand ratings.)		Space Factor	Catalog Number <sup>[1]</sup> Wiring Type B—Class I		Delivery Program
	208V	240V	380V- 415V	480V/600V	Rating (Amperes)	Class		NEMA Type 1 and Type 1 w/ gasket	NEMA Type 12	
1	0.125-7.5	0.125- 7.5	0.125-10	0.125-10	30	CC, J, R, H, HRCII-C,	3.0	2126FB-BA_ _	2126FB-BD_ _	PE
					60	J, R, H, HRCII-C				
2	10	10-15	15-25	15-25	30 <sup>[2]</sup>	J, R, H, HRCII-C	3.0	2126FB-CA_ _	2126FB-CD_ _	
					60	J, R, H, HRCII-C				
					100	J, HRCII-C				

[1] The catalog numbers listed are not complete:

- Select the control voltage type from table on page 205 (e.g., 2126FB-BABD).
- Select the horsepower from table on page 206 (e.g., 2126FB-BABD-31).
- If power fuse will NOT be selected, select fuse clip from table above. Then select clip designator from table on page 207 (e.g., 2126FB-BABD-31-24J).
- If power fuse WILL be selected, first select clip designator from table on page 207 (e.g., 2126FB-BABD-31-20J). Then select power fuse from table on page 207 (e.g., 2126FB-BABD-31GT-20J).
- For fuse rating based on load horsepower, see publication 2100-TD003x-EN-P.

The catalog numbers listed include an external reset button for the overload relay. To order catalog numbers **without** the external reset button, replace the letter "A" with the letter "K" (e.g., 2126FB-BK\_ \_) or replace the letter "D" with the letter "J" (e.g., 2126FB-BJ\_ \_).

[2] Available on 480 and 600 Volt applications only.

## Contactor and Starter Units

### Bulletin 2126J

#### Two Speed Reversing in Low Speed Only 2-Winding Starter Unit with Fusible Disconnect Switch (TSR2W)

- See page 34 for product description.
- Unit includes one set of 3-pole fuse clips.

**NOTE:** A two-speed 2-winding motor (TS2W) requires a mechanically and electrically interlocked assembly of two 3-pole contactors. A two-speed 1-winding motor (TS1W) requires a mechanically and electrically interlocked assembly of 3-pole and 5-pole contactors. Consult your local Rockwell Automation Sales Office for application assistance.

4

58

NEMA Size	Constant or Variable Torque Horsepower				Fuse Clip (See Appendix for short circuit withstand ratings.)		Space Factor	Catalog Number <sup>[1]</sup> Wiring Type B—Class I		Delivery Program
	208V	240V	380V-415V	480V/600V	Rating (Amperes)	Class		NEMA Type 1 and Type 1 w/ gasket	NEMA Type 12	
1	0.125-7.5	0.125-7.5	0.125-10	0.125-10	30	CC, J, R, H, HRCII-C	3.0	2126JB-BA_ _	2126JB-BD_ _	PE
					60	J, R, H, HRCII-C				
2	10	10-15	15-25	15-25	30 <sup>[2]</sup>	J, R, H, HRCII-C	3.0	2126JB-CA_ _	2126JB-CD_ _	
					60	J, R, H, HRCII-C				
					100	J, HRCII-C				

[1] The catalog numbers listed are not complete:

- Select the control voltage type from table on page 205 (e.g., 2126JB-BABD).
- Select the horsepower from table on page 206 (e.g., 2126JB-BABD-31).
- If power fuse will NOT be selected, select fuse clip from table above. Then select clip designator from table on page 207 (e.g., 2126JB-BABD-31-24J).
- If power fuse WILL be selected, first select clip designator from table on page 207 (e.g., 2126JB-BABD-31-20J). Then select power fuse from table on page 207 (e.g., 2126JB-BABD-31GT-20J).
- For fuse rating based on load horsepower, see publication 2100-TD003x-EN-P.

The catalog numbers listed include an external reset button for the overload relay. To order catalog numbers **without** the external reset button, replace the letter "A" with the letter "K" (e.g., 2126JB-BK\_ \_) or replace the letter "D" with the letter "J" (e.g., 2126JB-BJ\_ \_).

[2] Available on 480 and 600 Volt applications only.

### Bulletin 2126K

#### Two Speed Reversing in Low Speed Only 1-Winding Starter Unit with Fusible Disconnect Switch (TSR1W)

- See page 34 for product description.
- Unit includes one set of 3-pole fuse clips.

**NOTE:** A two-speed 2-winding motor (TSR2W) requires a mechanically and electrically interlocked assembly of two 3-pole contactors. A two-speed 1-winding motor (TSR1W) requires a mechanically and electrically interlocked assembly of 3-pole and 5-pole contactors. Consult your local Rockwell Automation Sales Office for application assistance.

59

NEMA Size	Constant or Variable Torque Horsepower				Fuse Clip (See Appendix for short circuit withstand ratings.)		Space Factor	Catalog Number <sup>[1]</sup> Wiring Type B—Class I		Delivery Program
	208V	240V	380V-415V	480V/600V	Rating (Amperes)	Class		NEMA Type 1 and Type 1 w/ gasket	NEMA Type 12	
1	0.125-7.5	0.125-7.5	0.125-10	0.125-10	30	CC, J, R, H, HRCII-C	3.0	2126KB-BA_ _	2126KB-BD_ _	PE
					60	J, R, H, HRCII-C				
2	10	10-15	15-25	15-25	30 <sup>[2]</sup>	J, R, H, HRCII-C	3.0	2126KB-CA_ _	2126KB-CD_ _	
					60	J, R, H, HRCII-C				
					100	J, HRCII-C				

[1] The catalog numbers listed are not complete:

- Select the control voltage type from table on page 205 (e.g., 2126KB-BABD).
- Select the horsepower from table on page 206 (e.g., 2126KB-BABD-31).
- If power fuse will NOT be selected, select fuse clip from table above. Then select clip designator from table on page 207 (e.g., 2126KB-BABD-31-24J).
- If power fuse WILL be selected, first select clip designator from table on page 207 (e.g., 2126KB-BABD-31-20J). Then select power fuse from table on page 207 (e.g., 2126KB-BABD-31GT-20J).
- For fuse rating based on load horsepower, see publication 2100-TD003x-EN-P.

The catalog numbers listed include an external reset button for the overload relay. To order catalog numbers **without** the external reset button, replace the letter "A" with the letter "K" (e.g., 2126KB-BK\_ \_) or replace the letter "D" with the letter "J" (e.g., 2126KB-BJ\_ \_).

[2] Available on 480 and 600 Volt applications only.

Two Speed Reversing 2-Winding Starter Unit with Circuit Breaker (TSR2W)

See page 34 for product description.

**NOTE:** A two-speed 2-winding motor (TSR2W) requires a mechanically and electrically interlocked assembly of two 3-pole contactors. A two-speed 1-winding motor (TSR1W) requires a mechanically and electrically interlocked assembly of 3-pole and 5-pole contactors. Consult your local Rockwell Automation Sales Office for application assistance.

60

NEMA Size	Constant or Variable Torque Horsepower				Space Factor	Catalog Number <sup>[1]</sup> Wiring Type B—Class I		Delivery Program
	208V	240V	380V-415V	480V/600V		NEMA Type 1 and Type 1 w/ gasket	NEMA Type 12	
1	0.125-7.5	0.125-7.5	0.125-10	0.125-10	3.0	2127EB-BA_ _ _	2127EB-BD_ _ _	PE
2	10	10-15	15-25	15-25	3.0	2127EB-CA_ _ _	2127EB-CD_ _ _	

[1] The catalog numbers listed are not complete:

- Select the control voltage type from table on page 205 (e.g., 2127EB-BABD).
- Select the horsepower from table on page 206 (e.g., 2127EB-BABD-31).
- Select the circuit breaker from Circuit Breaker Type table on page 211 (e.g., 2127EB-BABD-31CA).
- For circuit breaker size based on load horsepower, refer to publications 2100-TD001x-EN-P and 2100-TD002x-EN-P.

The catalog numbers listed include an external reset button for the overload relay. To order catalog numbers **without** the external reset button, replace the letter "A" with the letter "K" (e.g., 2127EB-BK\_ \_ \_) or replace the letter "D" with the letter "J" (e.g., 2127EB-BJ\_ \_ \_).

Two Speed Reversing 1-Winding Starter Unit with Circuit Breaker (TSR1W)

See page 34 for product description.

**NOTE:** A two-speed 2-winding motor (TSR2W) requires a mechanically and electrically interlocked assembly of two 3-pole contactors. A two-speed 1-winding motor (TSR1W) requires a mechanically and electrically interlocked assembly of 3-pole and 5-pole contactors. Consult your local Rockwell Automation Sales Office for application assistance.

61

NEMA Size	Constant or Variable Torque Horsepower				Space Factor	Catalog Number <sup>[1]</sup> Wiring Type B—Class I		Delivery Program
	208V	240V	380V-415V	480V/600V		NEMA Type 1 and Type 1 w/ gasket	NEMA Type 12	
1	0.125-7.5	0.125-7.5	0.125-10	0.125-10	3.0	2127FB-BA_ _ _	2127FB-BD_ _ _	PE
2	10	10-15	15-25	15-25	3.0	2127FB-CA_ _ _	2127FB-CD_ _ _	

[1] The catalog numbers listed are not complete:

- Select the control voltage type from table on page 205 (e.g., 2127FB-BABD).
- Select the horsepower from table on page 206 (e.g., 2127FB-BABD-30).
- Select the circuit breaker from Circuit Breaker Type table on page 211 (e.g., 2127FB-BABD-30CA).
- For circuit breaker size based on load horsepower, refer to publications 2100-TD001x-EN-P and 2100-TD002x-EN-P.

The catalog numbers listed include an external reset button for the overload relay. To order catalog numbers **without** the external reset button, replace the letter "A" with the letter "K" (e.g., 2127FB-BK\_ \_ \_) or replace the letter "D" with the letter "J" (e.g., 2127FB-BJ\_ \_ \_).

## Contactor and Starter Units

### Bulletin 2127J

#### Two Speed Reversing in Low Speed Only 2-Winding Starter Unit with Circuit Breaker (TSR2W)

See page 34 for product description.

**NOTE:** A two-speed 2-winding motor (TSR2W) requires a mechanically and electrically interlocked assembly of two 3-pole contactors. A two-speed 1-winding motor (TSR1W) requires a mechanically and electrically interlocked assembly of 3-pole and 5-pole contactors. Consult your local Rockwell Automation Sales Office for application assistance.

4

62

NEMA Size	Constant or Variable Torque Horsepower				Space Factor	Catalog Number <sup>[1]</sup> Wiring Type B—Class I		Delivery Program
	208V	240V	380V-415V	480V/600V		NEMA Type 1 and Type 1 w/ gasket	NEMA Type 12	
1	0.125-7.5	0.125- 7.5	0.125-10	0.125-10	3.0	2127JB-BA_ _ _	2127JB-BD_ _ _	PE
2	10	10-15	15-25	15-25	3.0	2127JB-CA_ _ _	2127JB-CD_ _ _	

[1] The catalog numbers listed are not complete:

- Select the control voltage type from table on page 205 (e.g., 2127JB-BABD).
- Select the horsepower from table on page 206 (e.g., 2127JB-BABD-30).
- Select the circuit breaker from Circuit Breaker Type table on page 211 (e.g., 2127JB-BABD-30CA).
- For circuit breaker size based on load horsepower, refer to publications 2100-TD001x-EN-P and 2100-TD002x-EN-P.

The catalog numbers listed include an external reset button for the overload relay. To order catalog numbers **without** the external reset button, replace the letter "A" with the letter "K" (e.g., 2127JB-BK\_ \_ \_) or replace the letter "D" with the letter "J" (e.g., 2127JB-BJ\_ \_ \_).

### Bulletin 2127K

#### Two Speed Reversing in Low Speed Only 1-Winding Starter Unit with Circuit Breaker (TSR1W)

See page 34 for product description.

**NOTE:** A two-speed 2-winding motor (TSR2W) requires a mechanically and electrically interlocked assembly of two 3-pole contactors. A two-speed 1-winding motor (TSR1W) requires a mechanically and electrically interlocked assembly of 3-pole and 5-pole contactors. Consult your local Rockwell Automation Sales Office for application assistance.

63

NEMA Size	Constant or Variable Torque Horsepower				Space Factor	Catalog Number <sup>[1]</sup> Wiring Type B—Class I		Delivery Program
	208V	240V	380V-415V	480V/600V		NEMA Type 1 and Type 1 w/ gasket	NEMA Type 12	
1	0.125-7.5	0.125-7.5	0.125-10	0.125-10	3.0	2127KB-BA_ _ _	2127KB-BD_ _ _	PE
2	10	10-15	15-25	15-25	3.0	2127KB-CA_ _ _	2127KB-CD_ _ _	

[1] The catalog numbers listed are not complete:

- Select the control voltage type from table on page 205 (e.g., 2127KB-BABD).
- Select the horsepower from table on page 206 (e.g., 2127KB-BABD-30).
- Select the circuit breaker type from Circuit Breaker Type table on page 211 (e.g., 2127KB-BABD-30CA).
- For circuit breaker size based on load horsepower, refer to publications 2100-TD001x-EN-P and 2100-TD002x-EN-P.

The catalog numbers listed include an external reset button for the overload relay. To order catalog numbers **without** the external reset button, replace the letter "A" with the letter "K" (e.g., 2127KB-BK\_ \_ \_) or replace the letter "D" with the letter "J" (e.g., 2127KB-BJ\_ \_ \_).



## Metering Units

### Bulletin 2190

#### Metering Compartments (METER)

See page 57 for product description.

#### **Ammeter:**

Panel type (not switchboard type) with 5A movement, 3.5" scale, 102° deflection, and 2% of full scale accuracy.

#### **Voltmeter:**

Phase-to-phase voltage measurement only. Panel type (not switchboard type) with 120V movement, 3.5" scale, 102° deflection, and 2% of full scale accuracy.

5

#### **Powermonitor 3000, Bulletin 1404-M5:**

1404-DM highly visible LED display. The monitor can display 64 real-time parameters, including current ( $I_a$ ,  $I_b$ ,  $I_c$ ,  $I_n$ ,  $I_3$ )<sub>avg</sub>,  $\pm 0.2\%$  full-scale accuracy, voltage ( $V_{an}$ ,  $V_{bn}$ ,  $V_{cn}$ ,  $V_{ab}$ ,  $V_{bc}$ ,  $V_{ca}$   $\pm 0.2\%$  full-scale accuracy), current, and voltage imbalance. There are four (4) forms of power (real, reactive, apparent, and true,  $\pm 0.4\%$  full-scale accuracy), kWh, KVARh, kVAH<sub>net</sub>, true RMS to the 45<sup>th</sup> harmonic, frequency ( $\pm 0.05\%$ ), and power factor ( $\pm 0.4\%$ ). The Powermonitor 3000 includes min./max, event logs, trend log (up to 45,867 data points), and distortion analysis with THD, crest factor (I, V), and distortion power factor. Every Powermonitor 3000 includes RS-485 communications as standard and has options for RS-232, DeviceNet, and Remote I/O. Also included are two form-C relays. The 1404-M5 can be flash upgraded to M6, and M8 PM3000 master modules. See your local Rockwell Automation representative for details.

#### **Powermonitor 3000, Bulletin 1404-M6:**

Same functionality as the Bulletin 1404-M5 except for the addition of harmonic analysis with TIF, Crest Factor, IEEE 519, and % THD and multiple channel and cycle oscillographic recordings. In addition, the same communication platforms are available.

#### **Digital Volt/Ammeter, Bulletin 1405-M610:**

The 1405-M610 measures and displays line-neutral and line-line voltages and the instantaneous, 15 minute averaged peak values of the measured phase currents are displayed sequentially. The features of the M610 include a 3-line display simultaneously showing all 3 phases, peak value storage and display, automatic sequencing of displayed parameters. The M610 also includes 35 pre-programmed standard current transformer ratios. A disconnect and current transformers are included in all 2190 metering units.

Analog Metering Compartments

Meter Type	Description		Line Voltage (Volts)	Space Factor	Catalog Number <sup>[1]</sup> Wiring Type A Only—Class I		Delivery Program
					NEMA Type 1 and Type 1 w/ gasket	NEMA Type 12	
Analog Ammeter	One (1) current transformer and panel type ammeter.	Current transformers shipped loose with hardware and mounting instructions. Metering mounted in door, no disconnect means, no unit insert.	600 Max.	0.5	2190-AKC-__-85AAXX	2190-AJC-__-85AAXX	SC
				1.0	2190-BKC-__-85AAXX	2190-BJC-__-85AAXX	
Analog Ammeter with Ammeter Switch	Two (2) current transformers, panel type ammeter, and ammeter switch. Use on 3-phase, 3-wire systems only.			0.5	2190-AKC-__-85BBXX	2190-AJC-__-85BBXX	
				1.0	2190-BKC-__-85BBXX	2190-BJC-__-85BBXX	
	Three (3) current transformers, panel type ammeter, and ammeter switch. Use on 3-phase, 3-wire systems only.			0.5	2190-AKC-__-85BCXX	2190-AJC-__-85BCXX	
				1.0	2190-BKC-__-85BCXX	2190-BJC-__-85BCXX	
Analog Ammeter and Voltmeter with Switches	Two (2) current transformers, panel type ammeter with ammeter switch, two (2) fused potential transformers, and panel type Voltmeter with Voltmeter switch. Use on 3-phase, 3-wire systems only.	Plug-in metering units with disconnect and fuses. Current transformers shipped loose with hardware and mounting instructions.	208	1.0	2190-BKH-__-85EBBH	2190-BJH-__-85EBBH	
			220/230		2190-BKP-__-85EBBP	2190-BJP-__-85EBBP	
			240		2190-BKA-__-85EBBA	2190-BJA-__-85EBBA	
			380		2190-BKN-__-85EBBN	2190-BJN-__-85EBBN	
			400		2190-BKKN-__-85EBBKN	2190-BJKN-__-85EBBKN	
			415		2190-BKI-__-85EBBI	2190-BJI-__-85EBBI	
			480		2190-BKB-__-85EBBB	2190-BJB-__-85EBBB	
			600		2190-BKC-__-85EBBC	2190-BJC-__-85EBBC	
	Three (3) current transformers, panel type ammeter with ammeter switch, two (2) fused potential transformers, and panel type Voltmeter with Voltmeter switch. Use on 3-phase, 3-wire systems only.		208	1.0	2190-BKH-__-85ECBH	2190-BJH-__-85ECBH	
			220/230		2190-BKP-__-85ECBP	2190-BJP-__-85ECBP	
			240		2190-BKA-__-85ECBA	2190-BJA-__-85ECBA	
			380		2190-BKN-__-85ECBN	2190-BJN-__-85ECBN	
			400		2190-BKKN-__-85ECBKN	2190-BJKN-__-85ECBKN	
			415		2190-BKI-__-85ECBI	2190-BJI-__-85ECBI	
			480		2190-BKB-__-85ECBB	2190-BJB-__-85ECBB	
			600		2190-BKC-__-85ECBC	2190-BJC-__-85ECBC	

5

[1] The catalog numbers listed are not complete. Select the appropriate catalog string number from table on page 60 to identify the ammeter scale and current transformer primary ratio (e.g., 2190-AKC-52M-85AAXX).

## Metering Units

### Bulletin 2190

#### Metering Compartments (METER), continued

#### Digital Metering Compartments

69

5

Meter Type	Description	Space Factor	Catalog Number <sup>[1]</sup> Wiring Type A Only—Class I		Delivery Program
			NEMA Type 1 and Type 1 w/ gasket	NEMA Type 12	
Bulletin 1404-M5 <sup>[2]</sup> Powermonitor 3000 with RS-485 Communications	Plug-in unit with disconnect, fuses, and control circuit transformer. For 3-phase, 3-wire systems, three (3) current transformers are shipped loose with hardware and mounting instructions. For 3-phase, 4-wire systems, four (4) current transformers are shipped loose with hardware and mounting instructions. Fused potential transformers are self-contained in the meter's power module.	1.0	2190-BK__-__-86U__X_	2190-BJ__-__-86U__X_	SC
Bulletin 1404-M6 <sup>[2]</sup> Powermonitor 3000 with RS-485 Communication		1.0	2190-BK__-__-86T__X_	2190-BJ__-__-86T__X_	
Bulletin 1405-M610 Digital Volt/Ammeter	For use on 3-phase, 3-wire systems only. Plug-in metering unit with disconnect and fuses. Current transformers shipped loose with hardware and mounting instructions. Potential transformers are internal to the device.	0.5	2190-AK__-__-86VCX_	2190-AJ__-__-86VCX_	SC

[1] The catalog numbers listed are not complete:

- Select the appropriate voltage code from Line Voltage table to identify the line voltage code. The voltage code must be in two places in the catalog string (e.g., 2190-BKB-54M-86UCCXB).
- Select the appropriate catalog string number from Ammeter Scales table to identify the current transformer primary ratio (e.g., 2190-BKB-54M-86UCCXB).
- For Powermonitor 3000 units, select the appropriate letter from Powermonitor 3000 Communication Options table to identify the communication platform (e.g., 2190-BKB-54M-86UCCXB).
- Select the appropriate letter from System Wiring table to identify the system wiring (e.g., 2190-BKB-54M-86UCCXB).

[2] For 3-wire power systems where L1-N, L1-G, L2-N, L2-G, L3-N, or L3-G may exceed 347V, consult factory.

#### Line Voltage

70

Line Voltage	Voltage Code
208	H
220/230	P
240	A
380	N
400	KN
415	I
480	B
600	C

#### Ammeter Scales

71

Ammeter Scale	Catalog String
300A	48M
400A	50M
600A	52M
800A	54M
1200A	56M
1600A	58M
2000A	60M

#### Powermonitor 3000 Communication Options

72

Platform	Letter Code
RS-485	A
RS-232 <sup>[1]</sup>	B
DeviceNet <sup>[1]</sup>	C
Remote I/O <sup>[1]</sup>	D
Ethernet <sup>[1]</sup>	E

[1] These communication platforms are in addition to the native RS-485.

#### System Wiring

73

System Wiring	Letter Code
3-phase, 3-wire	C
3-phase, 4-wire	D

# Main and Feeder Units

## Bulletin 2191F and 2191M

### Outgoing Feeder Lug Compartment (FLUG) and Incoming Main Lug Compartment (MLUG) ..... 62

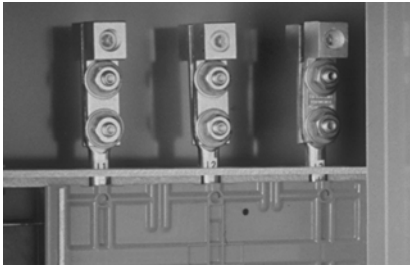

The Bulletin 2191M and 2191F are line lug compartments that provide a lug connection for incoming lines (2191M) to distribute power to the motor control center or for outgoing cables (2191F) to feed power from the MCC to an external load. These line lug compartments are available with ratings from 300 to 2000A. Optional mechanical or crimp lugs can be supplied with the lug compartments.

## Bulletin 2192F and 2192M

### Feeder and Main Fusible Disconnect Switch Units (FDS, MFDS) ..... 69

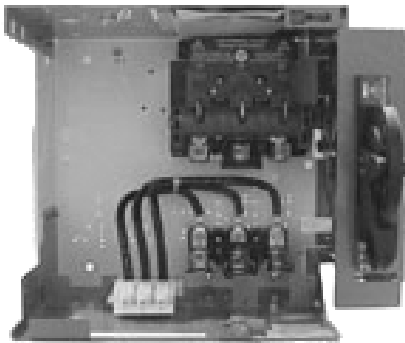

Bulletin 2192M and 2192F are fusible disconnect switches. These switches are available with ratings from 30A to 2000A. The 2192F is a plug-in unit for ratings up to 200A and frame mounted for ratings 400A and above. The 2192M is frame mounted (rigidly mounted and hardwired) in the structure for all ratings. The bolted pressure switch design is used for 2192 units rated 600A through 2000A.

## Bulletin 2193F and 2193M

### Feeder and Main Circuit Breaker Units (FCB, MCB) ..... 73

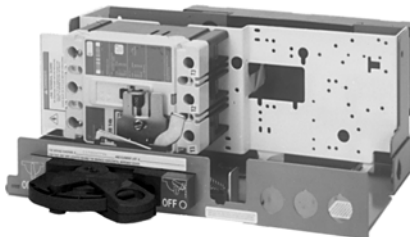

Bulletin 2193M and 2193F are circuit breaker units with trip ratings available from 15A to 2000A. These units are available with thermal magnetic trips up to 400A and electronic trips 600A and above. The 2193F is a plug-in unit for ratings up to 225A and is a frame mounted unit for ratings 400A and above. The 2193M is frame mounted for all ratings.

## Main and Feeder Units

### Catalog Number Explanation - Bulletin 2191F and 2191M Incoming and Outgoing Lug Compartment Units

- Line Lug Compartments
- Rated from 300 - 2000A
- Mechanical or crimp lugs are available

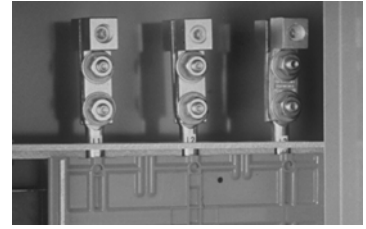

74

6

2191M		T		-		C		K		C		-		54		-		83D500-86UCCXB		-		**	
Bulletin Number		Mounting				Space Factor		Enclosure Type		Line Voltage				Amperes		Lug and Meter Options				Options			
74A						74C				74E						74G							
<b>Code</b>	<b>Type</b>			<b>Code</b>	<b>Space Factor</b>			<b>Code</b>	<b>Line Voltage</b>			<b>Code</b>	<b>Lug and Meter Options</b>					<b>Code</b>	<b>Options</b>				
2191F	Outgoing Feeder Lug Compartment (FLUG)			A	0 (mounted in top horizontal wireway)			C	Up to 600V			See tables on page 64-66.						See Options section beginning on page 107.					
2191M	Incoming Main Lug Compartment (MLUG)			B	1.0							74F											
				C	1.5							<b>Code</b>	<b>Amperes</b>										
				D	2.0							48	300A										
				J	4.5 (71" High Sections)							52	600A										
				M	6.0							54	800A										
				N	6.0 (Corner Section)							56	1200A										
				P	6.0 (10" Wide Section)							58	1600A										
												60	2000A										

Lug Compartments—Provisions for Basic Sections/Incoming Lines (MLUG) and Outgoing Feeders (FLUG)

- See page 61 for product description.
- All lugs compartments are frame mounted and must be located at top or bottom of section.
- Unit includes door, unit support pan, lug pads, and hardware.
- For metering options, refer to page 66.
- For 4-wire applications. Incoming neutral bus (see page 117) or neutral connection plates (see pages 25, 105, 117 and 214) are available for Bulletins 2191MT and 2191MB.
- For 71" high sections, see restrictions on page 24.  
**2191FT**—Top mounted feeder  
**2191FB**—Bottom mounted feeder  
**2191MT**—Top mounted main  
**2191MB**—Bottom mounted main
- Top- and bottom-mounted mains are designed with adequate space to route cables to lugs. Special consideration may need to be given to the mounting of the CT's for a metering device. Addition of a pull box might be considered.
- Refer to Appendix for wire size conversion table.

75

Rating (Amperes)	Cable Provisions Maximum Number Per Phase and Maximum Cable Size <sup>[1]</sup>			Space Factor	Catalog Number <sup>[2]</sup> Wiring Type A Only—Class I		Delivery Program
	Mechanical Type Lugs		Crimp Type Lugs		NEMA Type 1 and Type 1 w/ gasket	NEMA Type 12	
	Single Cable Lug	Multiple Cable Lug					
<b>PROVISIONS FOR BASIC SECTIONS</b>							
300	(2) 400 kcmil	—	(2) 350 kcmil	1.0 <sup>[5],[3]</sup>	2191F_-BKC-48	2191F_-BJC-48	SC-II
				1.0 <sup>[5],[7]</sup>	2191M_-BKC-48	2191M_-BJC-48	
600	(2) 400 kcmil	(4) 250 kcmil	(2) 350 kcmil	1.0 <sup>[4],[5]</sup>	2191F_-BKC-52	2191F_-BJC-52	
				1.0 <sup>[5]</sup>	2191M_-BKC-52	2191M_-BJC-52	
	(1) 500 kcmil	(2) 300 kcmil	(2) 350 kcmil	In top, horizontal wireway <sup>[6],[7]</sup>	2191MT-AKC-52	2191MT-AJC-52	
				(2) 750 kcmil	(4) 500 kcmil	(1) 750 kcmil (2) 500 kcmil	
800 <sup>[10]</sup>	(2) 800 kcmil (4) 600 kcmil	—	(2) 750 kcmil (4) 500 kcmil	6.0 <sup>[8],[9]</sup> , 20" W	2191_-MKC-52	2191_-MJC-52	
				1.0 <sup>[5],[6]</sup>	2191_T-BKC-54	2191_T-BJC-54	
	(1) 750 kcmil (2) 600 kcmil (4) 500 kcmil	—	(3) 500 kcmil (4) 350 kcmil	1.5 <sup>[5]</sup>	2191_-CKC-54	2191_-CJC-54	
800	(1) 800 kcmil (2) 750 kcmil (4) 600 kcmil	—	(2) 750 kcmil (4) 500 kcmil	2.0 <sup>[5]</sup>	2191_-DKC-54	2191_-DJC-54	
				6.0 <sup>[8],[9]</sup> , 20" W	2191_-MKC-54	2191_-MJC-54	
1200 <sup>[10]</sup>	(2) 800 kcmil (4) 600 kcmil	—	(2) 750 kcmil (4) 500 kcmil	1.0 <sup>[5],[6]</sup>	2191_T-BKC-56	2191_T-BJC-56	
				2.0 <sup>[5]</sup>	2191_-DKC-56	2191_-DJC-56	
1200	(4) 800 kcmil	—	(4) 750 kcmil	6.0 <sup>[8],[9]</sup> , 20" W	2191_-MKC-56	2191_-MJC-56	
1600					2191_-MKC-58	2191_-MJC-58	
2000					(6) 800 kcmil	—	(6) 750 kcmil

[1] Using a larger wire/lug size than is listed violates bend radius guidelines as listed in NEC/UL/cUL wire bending tables and voids UL/cUL listing and CSA certification.  
 [2] The catalog numbers listed are not complete:  
 • If required, insert M for main or F for feeder (e.g., 2191M or 2191F).  
 • If required, insert T for top mounted or B for bottom mounted (e.g., 2191MT or 2191MB).  
 • If using optional lugs, select from table on page 65. Then add catalog string number to base catalog number (e.g., 2191MT-CKC-52-82B500).  
 [3] The maximum possible rating of this unit is 300A. The rating of this unit can be determined by subtracting the current requirements of the units in the 3.0 space factors above or below this unit. Review NEC/CEC for further information.  
 [4] The maximum possible rating of this unit is 600A. The rating of this unit can be determined by subtracting the current requirements of the units in the 3.0 space factors above or below this unit. Review NEC/CEC for further information.  
 [5] Cannot be mounted in section containing other frame mounted units (transformer units excluded). Unit compartments 1.0 through 2.0 space factors must be located at top or bottom of section.  
 [6] Pullbox required. Must be mounted at top of vertical section. Cannot be mounted in section containing other frame mounted units (transformer units excluded).  
 [7] Not available with incoming neutral bus.  
 [8] Shipped in single shipping split only. Frame mounted unit, section does not have vertical wireway.  
 [9] Unit is 4.5 space factors in a 71" high section. The catalog number must be changed from 2191\_-M to 2191\_-J (e.g., 2191MT-JKC-52).  
 [10] Main and feeder rating must match horizontal bus rating. Full-rated neutral bus for 1200A, 2191M units requires a 6.0 space factor lug compartment.

## Main and Feeder Units

### Lug Compartments

#### Provisions for Inside Corner, 10" Wide Sections, and Neutrals/Incoming Line and Outgoing Feeders

- See page 24 for section descriptions.
  - Metering options not available.
  - For 71" high sections, see restrictions on page 24.
  - Refer to Appendix for wire size conversion table.
- 2191FT**—Top mounted feeder  
**2191FB**—Bottom mounted feeder  
**2191MT**—Top mounted main  
**2191MB**—Bottom mounted main

76

Rating (Amperes)	Cable Provisions <sup>[1]</sup> Maximum Number Per Phase and Maximum Cable Size		Space Factor	Catalog Number <sup>[2]</sup> Wiring Type A—Class I		Delivery Program
	Mechanical Type Lugs	Crimp Type Lugs		NEMA Type 1 and Type 1 w/ gasket	NEMA Type 12	
	Single Cable Lug					
<b>PROVISIONS FOR INSIDE CORNER SECTION</b>						
600	(4) 800 kcmil	(4) 750 kcmil	6.0 <sup>[3]</sup>	2191__-NKC-52	2191__-NJC-52	PE-II
800				2191__-NKC-54	2191__-NJC-54	
1200				2191__-NKC-56	2191__-NJC-56	
1600				2191__-NKC-58	2191__-NJC-58	
2000				2191__-NKC-60	2191__-NJC-60	
<b>PROVISIONS FOR 10" WIDE SECTION<sup>[4]</sup></b>						
600	Not Applicable	(2) 750 kcmil (4) 500 kcmil	6.0 <sup>[3]</sup>	2191__-PKC-52	2191__-PJC-52	PE-II
800				2191__-PKC-54	2191__-PJC-54	
1200				2191__-PKC-56	2191__-PJC-56	

[1] Using a larger wire/lug size than is listed violates bend radius guidelines as listed in NEC/UL/cUL wire bending tables and voids UL/cUL listing and CSA certification.

[2] The catalog numbers listed are not complete:

- Insert **M** for main or **F** for feeder (e.g., 2191**M** or 2191**F**).
- Insert **T** for top mounted or **B** for bottom mounted (e.g., 2191**MT** or 2191**MB**).
- If optional lugs will be selected, select from Lug Selection table on page 65. Then add catalog string number to base catalog number (e.g., 2191MT-CKC-52-**82B500**).

[3] Not available in 71" high sections, NEMA Type 3R, or Type 4.

[4] This section must be selected as part of a 2-section shipping block and shipped attached to a 20" wide section with standard depth horizontal power bus. It cannot be selected as free standing or attached to a 25" wide section with a 9" vertical wireway or any 6 space factor, frame-mounted unit. It is not available in NEMA Type 3R, Type 4, or back-to-back construction.

#### Lug Dimensions for Bulletin 2191F and 2191M

77

Lug Size	Number of Cables Per Lug	Dimension "A"	Refer to Figure
<b>MECHANICAL TYPE LUGS</b>			
#6-350 kcmil	1	2.13" (54 mm)	1
#4/0-600 kcmil <sup>[1]</sup>	1	2.31" (59 mm)	1
350-800 kcmil <sup>[2]</sup>	1	2.25" (57 mm)	1
#6-350 kcmil <sup>[3]</sup>	2	2.13" (54 mm)	2
#4/0-600 kcmil <sup>[3]</sup>	2	2.13" (54 mm)	2
<b>CRIMP TYPE LUGS (Panduit Type LCC)</b>			
250 kcmil	1	2.94" (75 mm)	3
350 kcmil		3.38" (86 mm)	
500 kcmil		3.78" (96 mm)	
750 kcmil		4.63" (118 mm)	
<b>CRIMP TYPE LUGS (Burdny YA-A Series)</b>			
250 kcmil	1	2.91" (74 mm)	3
350 kcmil		3.69" (94 mm)	
500 kcmil		4.44" (113 mm)	
750 kcmil		4.94" (125 mm)	

[1] Recommended lug for 1600A and 2000A lug compartments.

[2] Two (2) lugs per phase only when used on 1200A lug compartment.

[3] Used in a wireway when more than 2 cables per phase are specified in a 1.0 or 1.5 space factor 600A lug compartment.

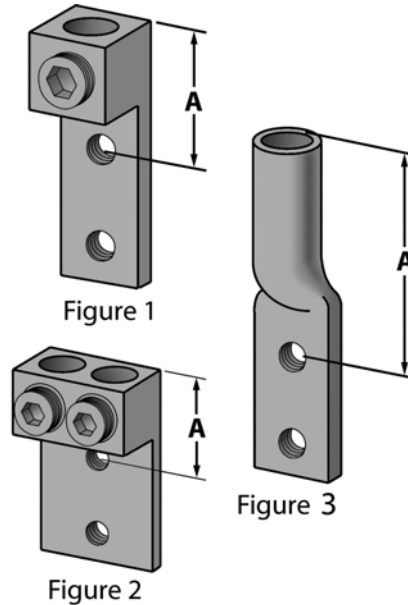

Lugs shown are drilled for 2-hole NEMA 1.75" spacing.

## Lug Compartments, continued

- CENTERLINE 2100 motor control centers are rated for use with 75°C wire. Wire must be sized using the 75°C column in NEC/UL/cUL. The actual temperature rating of the lug is not relevant.
- Refer to the Appendix for a wire size conversion table.

## Lug Selection

78

Wire/Cable Size	Catalog String No. [1]	Wire Range
<b>MECHANICAL TYPE LUGS FOR ALUMINUM/COPPER WIRE [2]</b>		
#6 AWG	-80_006	#6-350 kcmil
#4 AWG	-80_004	
#2 AWG	-80_002	
#1 AWG	-80_001	
#1/0 AWG	-80_1X0	
#2/0 AWG	-80_2X0	
#3/0 AWG	-80_3X0	
#4/0 AWG	-80_4X0	
250 kcmil	-80_250	
300 kcmil	-80_300	
350 kcmil	-80_350	#4/0-600 kcmil
400 kcmil	-80_400	
500 kcmil	-80_500	
600 kcmil	-80_600	350-800 kcmil
700 kcmil	-80_700	
750 kcmil	-80_750	
800 kcmil	-80_800	
<b>CRIMP TYPE LUGS (Panduit Type LCC) FOR COPPER WIRE</b>		
250 kcmil	-82_250	—
350 kcmil	-82_350	
500 kcmil	-82_500	
750 kcmil	-82_750	
<b>CRIMP TYPE LUGS (Burdyn YA-A Series) FOR ALUMINUM or COPPER WIRE</b>		
250 kcmil	-83_250	—
350 kcmil	-83_350	
500 kcmil	-83_500	
750 kcmil	-83_750	

- [1] Catalog string numbers listed are not complete. Select the appropriate letter from Lug Quantity table to identify the number of cables per phase desired (e.g., 2191MT-AAC-52-80B4X0). When optional neutral incoming bus is desired, optional neutral lugs will be the same type as those for 3-phase cable. Only one option code is needed.
- [2] Mechanical lugs are available for use with 42kA bus bracing. For applications requiring over 42kA bus bracing, use crimp type lugs only.

## Lug Quantity

79

Letter	Number of Cables per Phase [1]
A	1
B	2
C	3
D	4
E	5
F	6

- [1] If optional full-rated incoming neutral bus (see page 117) is specified, the quantity and size/type of the lug(s) on neutral lug pad will be the same as the 3-phase lugs. When optional half-rated incoming neutral bus (see page 117) is specified and (1) or (2) lugs per phase are specified, (1) lug will be provided on the half-rated neutral riser. When (3) or (4) lugs are specified, (2) lugs will be provided. When (5) or (6) lugs are specified, (3) lugs will be provided on half-rated neutral riser.

## Main and Feeder Units

### Bulletin 2191M

#### Lug Compartments/Incoming Lines Metering Options

- Metering options may not be used on units specified with ground detection lights. See page 116.
- Metering options on 6.0 space factor bottom entry units will be mounted 22" (554 mm) from the floor. A separate metering unit may be preferred.
- Top- and bottom-mounted mains are designed with adequate space to route cables to lugs. Special consideration may need to be given to the mounting of the CT's for a metering device. Addition of a pull box might be considered.
- See page 57 for meter specifications.

80

Meter Type <sup>[1]</sup>	Description	Catalog String Number for Metering Option Line Voltage <sup>[2]</sup>								Delivery Program
		208V	220/230V	240V	380V	400V	415V	480V	600V	
Analog Ammeter	Includes one (1) current transformer and panel type ammeter	--85AAXX	--85AAXX	--85AAXX	--85AAXX	--85AAXX	--85AAXX	--85AAXX	--85AAXX	SC-II
Analog Ammeter with Ammeter Switch	Includes two (2) current transformers, panel type ammeter, and ammeter switch. Use on 3-phase, 3-wire systems only.	--85BBXX	--85BBXX	--85BBXX	--85BBXX	--85BBXX	--85BBXX	--85BBXX	--85BBXX	
	Includes three (3) current transformers, panel type ammeter, and ammeter switch. Use on 3-phase, 3-wire systems only.	--85BCXX	--85BCXX	--85BCXX	--85BCXX	--85BCXX	--85BCXX	--85BCXX	--85BCXX	
Analog Voltmeter	Includes one (1) fused potential transformer (mounted in compartment) and panel type Voltmeter	--85CXAH	--85CXAP	--85CXAA	--85CXAN	--85CXAKN	--85CXAI	--85CXAB	--85CXAC	
Analog Voltmeter with Voltmeter Switch	Includes two (2) fused potential transformers (mounted in compartment), panel type Voltmeter, and Voltmeter switch. For 3-phase, 3-wire systems only.	--85HXBH	--85HXBP	--85HXBA	--85HXBN	--85HXBKN	--85HXBI	--85HXBB	--85HXBC	
Analog Ammeter and Voltmeter with Switches	Two (2) current transformers, panel type ammeter with ammeter switch, two (2) fused potential transformers, and panel type Voltmeter with Voltmeter switch	--85EBBH	--85EBBP	--85EBBA	--85EBBN	--85EBBKN	--85EBBI	--85EBBB	--85EBBC	
	Three (3) current transformers, panel type ammeter with ammeter switch, two (2) fused potential transformers, and panel type Voltmeter with Voltmeter switch	--85ECBH	--85ECBP	--85ECBA	--85ECBN	--85ECBKN	--85ECBI	--85ECBB	--85ECBC	
Bul. 1404-M5 Powermonitor 3000 with RS-485 Communication <sup>[3]</sup>	Display module mounted on door. Includes control circuit transformer. For 3-phase, 3-wire systems, three (3) current transformers ship loose with hardware and mounting instructions. For 3-phase, 4-wire systems, four (4) current transformers ship loose with hardware and mounting instructions. Disconnect switch is not included.	--86U__XH	--86U__XP	--86U__XA	--86U__XN	--86U__XKN	--86U__XI	--86U__XB	--86U__XC	SC-II
Bul. 1404-M6 <sup>[3]</sup> Powermonitor 3000 with RS-485 Communication		--86T__XH	--86T__XP	--86T__XA	--86T__XN	--86T__XKN	--86T__XI	--86T__XB	--86T__XC	
Bulletin 1405-M610 Digital Volt/Ammeter	For use on 3-phase, 3-wire systems only. Plug-in metering unit with disconnect and fuses. Current transformers shipped loose with hardware and mounting instructions. Potential transformers are internal to the device.	--86VCXH	--86VCXP	--86VCXA	--86VCXN	--86VCXKN	--86VCXI	--86VCXB	--86VCXC	SC-II

[1] Metering not available in 2191M 600A main lugs in horizontal wireway.

[2] The option numbers listed are not complete:

- Select the appropriate catalog string number from Ammeter Scale and Current Transformer Primary Ratio table to identify the current transformer primary ratio (e.g., -54M-86UCCXB).
- Select the appropriate letter from the Powermonitor 3000 Communication Options table to identify the communication platform for Powermonitor 3000 units (e.g., -54M-86UCCXB).
- Where applicable, select the appropriate letter from System Wiring table to identify the system wiring (e.g., -54M-86UCCXB).

[3] For 3-wire power systems where L1-N, L1-G, L2-N, L2-G, L3-N, or L3-G may exceed 347V, consult factory.

#### Ammeter Scale and Current Transformer Primary Ratio 81

Amperes	Catalog String Number
300A	48M
600A	52M
800A	54M
1200A	56M
1600A	58M
2000	60M

#### System Wiring 82

System	Cat. String
3-phase, 3-wire	C
3 phase, 4 wire	D

#### Powermonitor 3000 Communication Options 83

Platform	Letter Code
RS-485	A
RS-232 <sup>[1]</sup>	B
DeviceNet <sup>[1]</sup>	C
Remote I/O <sup>[1]</sup>	D
Ethernet <sup>[1]</sup>	E

[1] These communication platforms are in addition to the native RS-485.

- Lug pads shown on page 68 are drilled for 2-hole NEMA 1.75" spacing.
- Top- and bottom-mounted mains are designed with adequate space to route cables to lugs. Special consideration may need to be given to the mounting of the CT's for a metering device. Addition of a pull box might be considered.

84

	Compartment Size (Space Factor)	Ratings (Amperes)	Refer to Figure [1]	Dimensions A			Dimension B Total Available Space with Pullbox	Maximum No. of Cables per Phase	Maximum Number of Lugs per Phase	
				L1	L2	L3			Single Cable	Double Cable
Top Entry [2]	In horiz. WW (pullbox required)	600	1	—	—	—	13.19" (335 mm)	2	1	1
	1.0	300	2	12.81" (325 mm)	12.81" (325 mm)	12.81" (325 mm)	24.81" (630 mm)	2	2	—
	1.0	600	2	12.81" (325 mm)	12.81" (325 mm)	12.81" (325 mm)	24.81" (630 mm)	4	2	2
	1.0 (pullbox required)	800 1200	3	—	—	—	21.56" (548 mm)	4	4	N/A
	1.5	600 800	2 3	19.31" (490 mm)	19.31" (490 mm)	19.31" (490 mm)	31.31" (795 mm)	4	2	2
				15.75" (400 mm)	15.75" (400 mm)	15.75" (400 mm)	27.75" (705 mm)	4	4	
	2.0	800 1200	3	16.63" (422 mm) <sup>[3]</sup>	16.63" (422 mm) <sup>[3]</sup>	16.63" (422 mm) <sup>[3]</sup>	28.63" (727 mm)	2	2	
				20.00" (508 mm)	20.00" (508 mm)	20.00" (508 mm)	32.00" (813 mm)	4	4	
	2.0	800 1200	3	20.88" (530 mm) <sup>[3]</sup>	20.88" (530 mm) <sup>[3]</sup>	20.88" (530 mm) <sup>[3]</sup>	32.88" (835 mm)	2	2	
				20.88" (530 mm) <sup>[3]</sup>	20.88" (530 mm) <sup>[3]</sup>	20.88" (530 mm) <sup>[3]</sup>	32.88" (835 mm)	2	2	
6.0 (20" wide)	600 800 1200 1600	4	37.63" (956 mm)	44.13" (1121 mm)	50.63" (1286 mm)	—	4	4	N/A	
			2000	4	37.63" (956 mm)	44.13" (1121 mm)	50.63" (1286 mm)	—		6
6.0 (corner section)	600 800 1200 1600 2000	5	37.63" (956 mm)	44.13" (1121 mm)	50.63" (1286 mm)	—	4	4		
6.0 (10" wide)	600 800 1200	6	35.88" (911 mm)	42.38" (1076 mm)	48.88" (1242 mm)	—	4	4		

6

[1] See page 68 for figures.

[2] Depending on wire size and wires per phase, pullbox may be required to meet wire bending radius as specified by NEC/UL/cUL.

[3] When cable size selected limits the user to two (2) single lugs per phase, Dimension A is measured from center set of holes in lug pad. See Figure 3 on page 68.

85

	Compartment Size (Space Factor)	Ratings (Amperes)	Refer to Figure [1]	Dimensions A			Maximum No. of Cables per Phase	Maximum Number of Lugs per Phase	
				L1	L2	L3		Single Cable	Double Cable
Bottom Entry	1.0	300	2	12.81" (325 mm)	12.81" (325 mm)	12.81" (325 mm)	2	2	N/A
	1.0	600	2	12.81" (325 mm)	12.81" (325 mm)	12.81" (325 mm)	4	2	2
	1.5	600 800	2 3	19.31" (490 mm)	19.31" (490 mm)	19.31" (490 mm)	4	2	2
				15.75" (400 mm)	15.75" (400 mm)	15.75" (400 mm)	4	4	
	2.0	800 1200	3	16.63" (422 mm) <sup>[2]</sup>	16.63" (422 mm) <sup>[2]</sup>	16.63" (422 mm) <sup>[2]</sup>	2	2	
				20.00" (508 mm)	20.00" (508 mm)	20.00" (508 mm)	4	4	
	2.0	800 1200	3	20.88" (530 mm) <sup>[2]</sup>	20.88" (530 mm) <sup>[2]</sup>	20.88" (530 mm) <sup>[2]</sup>	2	2	
				20.88" (530 mm) <sup>[2]</sup>	20.88" (530 mm) <sup>[2]</sup>	20.88" (530 mm) <sup>[2]</sup>	2	2	
	6.0 (20" wide)	600 800 1200 1600	4	50.63" (1286 mm)	44.13" (1121 mm)	37.63" (956 mm)	4	4	N/A
				2000	4	50.63" (1286 mm)	44.13" (1121 mm)	37.63" (956 mm)	
6.0 (corner section)	600 800 1200 1600 2000	5	50.63" (1286 mm)	44.13" (1121 mm)	37.63" (956 mm)	4	4		
6.0 (10" wide)	600 800 1200	6	48.88" (1242 mm)	42.38" (1076 mm)	35.88" (911 mm)	4	4		

[1] See page 68 for figures.

[2] When cable size selected limits the user to two (2) single lugs per phase, Dimension A is measured from center set of holes in lug pad. See Figure 3 on page 68.

Bulletin 2191M

Lug Compartments/Incoming Line—Dimensions

Dimensions for drawings are provided on page 67.

6

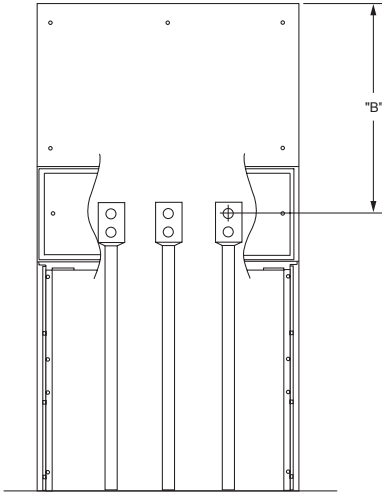

FIGURE 1

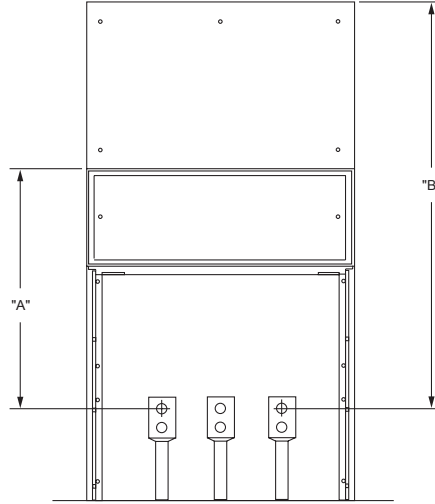

FIGURE 2

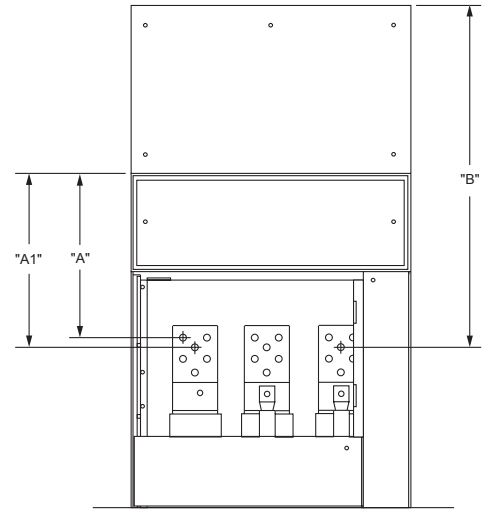

FIGURE 3

Phase A vertical bus on top incoming 2.0 space factors and Phase C vertical bus on bottom incoming 2.0 space factors are not required or supplied

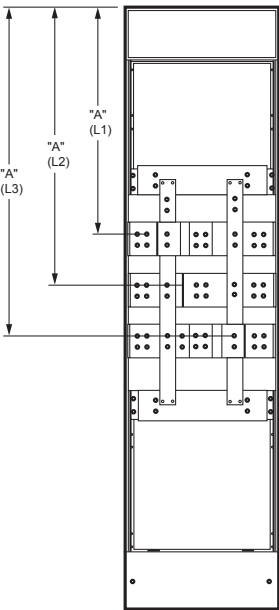

FIGURE 4

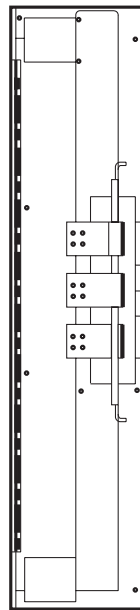

FIGURE 5

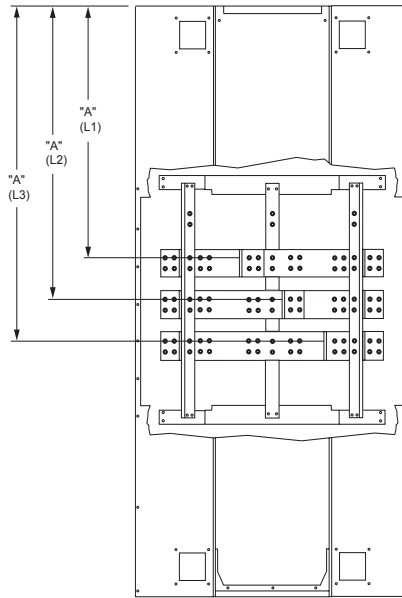

FIGURE 6

**NOTE:** All lug pads shown accept NEMA standard 2-hole lugs 1.75" on center using .5" hardware.



## Main and Feeder Units

### Bulletin 2192F

#### Fusible Disconnect Switch—Feeders (FDS)

- See page 61 for product description.
- Select disconnect switch rating based upon 125% of actual load amperes. Refer to NEC/CEC.
  - 2192FZ**—Plug-in unit, 0.5 space factor, 30A only.
  - 2192F**—Plug-in unit, 30A-200A.
  - 2192FT**—Top-mounted feeder, 400A are top-fed, connect load to bottom of switch.
  - 2192FT**—Top-mounted feeder, 600A-1200A are reverse-fed, connect load to top of switch.
  - 2192FB**—Bottom-mounted feeder, 400A-1200A are top-fed, connect load to bottom of switch.
- Refer to Appendix for horsepower ratings.
- Refer to Appendix for wire size conversion table.

87

6

Switch Rating (Amperes)	Fuse Clip Rating (Amperes)	Fuse Clip Class	Load Lugs Provided			Space Factor	Catalog Number <sup>[1]</sup> Wiring Type A Only—Class I		Delivery Program
			Cables/Phase	Cable/Wire Size Range	Wire Type		NEMA Type 1 or Type 1 w/ gasket	NEMA Type 12	
30	30	CC, J	1	#14-#8 AWG	CU	0.5	2192FZ-BKC-__	2192FZ-BJC-__	SC
30	30	CC, J, R, H	1	#14-#4 AWG	CU	1.0	2192F-BK_-__	2192F-BJ_-__	
60	60	J, R, H	1			1.0	2192F-CK_-__	2192F-CJ_-__	
Dual 30 <sup>[2]</sup>	30						2192F-BK_-2424__	2192F-BJ_-2424__	
Dual 60/30 <sup>[2]</sup>	60/30	J, R, H	1	1.5	2192F-CK_-2524__	2192F-CJ_-2524__			
Dual 60 <sup>[2]</sup>	60				2192F-CK_-2525__	2192F-CJ_-2525__			
Dual 100/30 <sup>[2]</sup>	100/30	J, R, H	1	1.5	2192F-DK_-2624__	2192F-DJ_-2624__			
Dual 100/60 <sup>[2]</sup>	100/60				2192F-DK_-2625__	2192F-DJ_-2625__			
Dual 100 <sup>[2]</sup>	100	J, R, H	1	2.0	2192F-DK_-2626__	2192F-DJ_-2626__			
100	100				2192F-DK_-__	2192F-DJ_-__			
200	200	J, R, H, L	1	2.5 <sup>[3]</sup>	2192F-EK_-__	2192F-EJ_-__			
400	400				2192F_-FK_-__	2192F_-FJ_-__			
600	600	J, R, H, L	2	3.5 <sup>[4]</sup>	2192F_-GK_-__	2192F_-GJ_-__			
800	800				2192F_-HKC_-__	2192F_-HJC_-__			
1200	1200	L	4	3.5 <sup>[4]</sup>	2192F_-JKC_-__	2192F_-JJC_-__	SC-II		

[1] The catalog numbers listed are not complete:

- For 400-1200 Amperes, insert **T** for Top mounted or **B** for Bottom mounted (e.g., 2192FT- or 2192FB-).
- Unless already selected, select the voltage from Fuse Clip Voltage table (e.g., 2192F-BKC).
- Select the fuse clip designator from Fuse Clip Sizes/Types table (e.g., 2192F-BKC-**24J**). For duals, add letter suffix only—numbers are already supplied in catalog number (e.g., 2192F-CKA-**2525J**).
- If power fuse will be selected, select from table on page 208 (e.g., 2192F-BKC-24J-**603G**). Double code number for duals (e.g., 603603G).
- For fuse rating, based on disconnect rating, see publication 2100-TD003x-EN-P.
- If optional load lugs will be selected, select from table on page 72. Add option number to base catalog number (e.g., 2192F-GKC-29R-603G-**82B500**).

[2] Not available with DSA (options 11DSA2 and 11DSA3).

[3] Frame mounted unit. Must be located at top or bottom of section.

[4] Frame mounted unit, section does not have vertical wireway next to this unit. Must be located at top or bottom of section. May not be mounted in section containing other frame mounted units.

88

#### Fuse Clip Voltage

Fuse Clip Voltage	Voltage Code
220-230	P <sup>[2]</sup>
240	A <sup>[2]</sup>
250	A <sup>[1]</sup>
380	N <sup>[2]</sup>
400	KN <sup>[2]</sup>
415	I <sup>[2]</sup>
480	B <sup>[2]</sup>
600	C

#### Fuse Clip Sizes/Types and UL Listed Short Circuit Withstand Ratings for Fusible Disconnect Switch Units (2192FT, 2192FB, 2192MT, 2192MB)

Fuse Clip Type	Fuse Clip Designator (Amperes)										Available Short Circuit Amperes (rms symmetrical) through 600V
	30A	60A	100A	200A	400A	600A	800A	1200A	1600A	2000A	
J	24J	25J	26J	27J	28J	29J	—	—	—	—	100kA
R	24R	25R	26R	27R	28R	29R	—	—	—	—	100kA
H	24	25	26	27	28	29	—	—	—	—	10kA
L	—	—	—	—	—	23L <sup>[3]</sup>	24L	25L	26L	27L	100kA
CC	24C	—	—	—	—	—	—	—	—	—	100kA
Non-Fused <sup>[4]</sup>	—	—	—	—	—	00N	00N	00N	00N	00N	100kA <sup>[5]</sup>

[1] Not available for 1600A or 2000A 2192M.

[2] These voltage codes are to be used only when ground fault protection (option 88GF) is selected on 1600A-2000A 2192M units.

[3] For 600A, 100% rated, Class L fuses are the only valid option. 23L indicates provision for a 601A, Class L.

[4] Available on mains (2192MT, 2192MB) only. This is 100% rated and can be supplied in NEMA 1, 1 with gasket, and 12. Not available as standard with 100kA series coordinated bus bracing, consult factory.

[5] Short circuit withstand is 100kA only when protected upstream with Class L fuses that are sized in accordance with particular switch (e.g., 800A upstream fuses are to be used with 800A switch or 2000A upstream fuses are to be used with 2000A switch).

- See page 61 for product description.
- Select disconnect switch rating based upon 125% of actual load amperes. Refer to NEC/UL/cUL.
- Mains are suitable for use as service entrance per NEC (UL) and CEC (CSA). If application is a four-wire system, a neutral connection plate rated for 280A is available. Select on pages 25, 105, 117 and 214. If a Neutral connection greater than 280A is required, refer to page 25 and page 117 or contact your local Rockwell Automation Sales Office.
- Mains rated 1000A and above may require ground fault protection. For 1000-1200A applications that require ground fault protection, contact your local Rockwell Automation Sales Office. For 1600-2000A applications that require ground fault protection, see option 88GF on page 116.
- Non-fused mains are available in 600A through 2000A. See Fuse Clip Sizes/Types table on page 70.  
**2192MT**—Top-mounted main, 30A-2000A are top-fed.  
**2192MB**—Bottom-mounted main, 30A-400A are top-fed.  
**2192MB**—Bottom-mounted main, 600A-2000A are reverse-fed.
- Top- and bottom-mounted mains are designed with adequate space to route cables to lugs. Special consideration may need to be given to the mounting of the CT's for a metering device. Addition of a pull box might be considered.
- Refer to Appendix for wire size conversion table.
- Includes line terminal guard.

Switch Rating (Amperes)	Fuse Clip		Line Lugs Provided			Space Factor	Catalog Number <sup>[1]</sup> Wiring Type A Only—Class I		Delivery Program
	Rating (Amperes)	Class	Cables/Phase	Cable/Wire Size Range <sup>[2]</sup>	Wire Type		NEMA Type 1 and Type 1 w/ gasket	NEMA Type 12	
30	30	J, R, H	1	#14-#8 AWG	CU	1.5 <sup>[3]</sup>	2192M_-BK_-__	2192M_-BJ_-__	SC-II
60	60		1	#14-#6 AWG	CU		2192M_-CK_-__	2192M_-CJ_-__	
100	100		1	#8-1/0 AWG	CU		2192M_-DK_-__	2192M_-DJ_-__	
200	200		1	#6-4/0 AWG	CU	2.0 <sup>[3]</sup>	2192M_-EK_-__	2192M_-EJ_-__	
400	400		2	1/0-250 kcmil	CU		2.5 <sup>[3]</sup>	2192M_-FK_-__	
600 <sup>[5],[6]</sup>	600	J, R, H, L	2	#2-600 kcmil	CU/AL	3.5 <sup>[4]</sup>	2192M_-GK_-__	2192M_-GJ_-__	
800 <sup>[5],[6]</sup>	800	L	3	#6-350 kcmil	CU/AL		2192M_-HK_-__	2192M_-HJ_-__	
1200 <sup>[5],[6]</sup>	1200		4	#6-350 kcmil	CU/AL		2192M_-JK_-__	2192M_-JJ_-__	
1600 <sup>[5],[6],[7]</sup>	1600		4	#2-600 kcmil	CU/AL	6.0	2192M_-KK_-__	2192M_-KJ_-__	
2000 <sup>[5],[6],[7]</sup>	2000		6	#2-600 kcmil	CU/AL		20" D 35" W <sup>[8]</sup>	2192M_-LK_-__	

[1] The catalog numbers listed are not complete:

- Insert **T** for Top mounted or **B** for Bottom mounted (e.g., 2192MT- or 2192MB-).
- Unless already selected, select the voltage code from table on page 70 (e.g., 2192MT-GKC).
- Then select the appropriate fuse clip designator from Fuse Clip Sizes/Types on page 70 (e.g., 2192MT-GKC-29J).
- If power fuse will be selected, select from table on page 208 (e.g., 2192MT-GKC-29J-629G).
- For fuse rating, based on disconnect rating, see publication 2100-TD003x-EN-P.
- If optional line lugs will be selected, select from Optional Crimp Lugs for Bulletins 2192FT, 2192FB, 2192MT and 2192MB table below (e.g., 2192MT-GKC-29J-629G-82B500).

[2] If optional full-rated incoming neutral bus (see page 117) is specified, the quantity and size/type of the lug(s) on neutral lug pad will be the same as the 3-phase lugs. When optional half-rated incoming neutral bus (see page 117) is specified and (1) or (2) lugs per phase are specified, (1) lug will be provided on the half-rated neutral riser. When (3) or (4) lugs are specified, (2) lugs will be provided. When (5) or (6) lugs are specified, (3) lugs will be provided on half-rated neutral riser.

[3] Frame mounted unit. Must be located at top or bottom of section.

[4] Frame mounted unit, section does not have vertical wireway next to this unit. Must be located at top or bottom of section. May not be mounted in section containing other frame mounted units.

[5] Fusible disconnect switch is a bolted pressure switch. No vertical wireway. Not available in NEMA Type 3R or Type 4 for 1600A and 2000A. 600A through 1200A units have viewing window on door for visual verification of disconnect blades.

[6] Units having 100% ratings are available for these fusible disconnect switches for NEMA Type 1 and Type 1 with gasket only. Non-fused switches are 100% rated and available in NEMA 1, 1 with gasket, and 12. See options on page 122 to select. For 100% rated 1600A and 2000A units, no top or bottom wireway is present above or below the unit and the unit must be located at either end of the motor control center lineup.

[7] When used with a 3-phase, 4-wire power system, horizontal neutral bus and incoming neutral bus is required.

[8] Frame mounted unit, section does not have vertical wireway. Horizontal bus is 5" deeper than standard. A special bus splice kit is provided when this unit is supplied adjacent to a section with standard depth bus.

## Main and Feeder Units

### Optional Crimp Lugs for Bulletins 2192FT, 2192FB, 2192MT and 2192MB

90

Switch Size	Type of Lug	Cables/ Phase	Cable/Wire Size or Range	Wire Type	Option Number <sup>[1]</sup>	2192FT 2192FB	2192MT 2192MB
200A	Mechanical Only	1	#6-250 kcmil	CU	81A250	✓	✓
400A	Panduit Type LCC	2	250 kcmil	CU	82B250		✓ <sup>[2],[3]</sup>
		1	500 kcmil	CU	82A500		✓ <sup>[2],[3],[4]</sup>
	Burndy YA-A Series	2	250 kcmil	CU/AL	83B250		✓ <sup>[2],[3]</sup>
		1	500 kcmil	CU/AL	83A500		✓ <sup>[2],[3],[4]</sup>
600A	Panduit Type LCC	2	500 kcmil	CU	82B500	✓ <sup>[3]</sup>	✓ <sup>[3]</sup>
	Burndy YA-A Series	2		CU/AL	83B500	✓ <sup>[3]</sup>	✓ <sup>[3]</sup>
800A	Panduit Type LCC	3		CU	82C500	✓ <sup>[3]</sup>	✓ <sup>[3]</sup>
	Burndy YA-A Series	3		CU/AL	83C500	✓ <sup>[3]</sup>	✓ <sup>[3]</sup>
1200A	Panduit Type LCC	4		CU	82D500	✓ <sup>[3]</sup>	✓ <sup>[3]</sup>
	Burndy YA-A Series	4		CU/AL	83D500	✓ <sup>[3]</sup>	✓ <sup>[3]</sup>
1600A	Panduit Type LCC	5		CU	82E500		✓ <sup>[3]</sup>
	Burndy YA-A Series	5		CU/AL	83E500		✓ <sup>[3]</sup>
2000A	Panduit Type LCC	6		CU	82F500		✓ <sup>[3]</sup>
	Burndy YA-A Series	6		CU/AL	83F500		✓ <sup>[3]</sup>

[1] If optional full-rated incoming neutral bus (see page 117) is specified, the quantity and size/type of the lug(s) on neutral lug pad will be the same as the 3-phase lugs. When optional half-rated incoming neutral bus (see page 117) is specified and (1) or (2) lugs per phase are specified, (1) lug will be provided on the half-rated neutral riser. When (3) or (4) lugs are specified, (2) lugs will be provided. When (5) or (6) lugs are specified, (3) lugs will be provided on half-rated neutral riser.

[2] For top entry of incoming cables only.

[3] Disconnect supplied with lug pad assembly, reference page 215 for additional lugs.

[4] Requires pullbox. Select on page 28.

## Catalog Number Explanation - Bulletin 2193F and 2193M Circuit Breaker Feeders and Mains

- 150A and 250A Frame Feeders through 225A Trip are Plug-In Units
- 400-2000A Frame Feeders and all Mains are Frame Mounted
- Mains 600-2000A available with Built in Ground Fault Protection

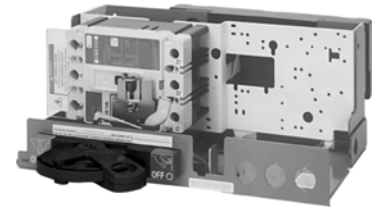

91

<b>2193F</b>	<b>T</b>	<b>B</b>	<b>K</b>	<b>C</b>	<b>30CB</b>	<b>**</b>	<b>6</b>
<i>Bulletin Number</i>	<i>Mounting</i>	<i>Max Trip Rating</i>	<i>NEMA Enclosure Type</i>	<i>Line Voltage</i>	<i>Circuit Breaker Trip Size and Type</i>	<i>Options</i>	
91A		91C		91E	91F		
<b>Code</b>	<b>Type</b>	<b>Code</b>	<b>Trip Rating</b>	<b>Code</b>	<b>Line Voltage</b>	<b>Code</b>	<b>Circuit Breaker Trip Size and Type</b>
2193F	Circuit Breaker Feeder (FCB)	A	100A	C	Up to 600V		See table on page 76.
2193M	Main Circuit Breaker (MCB)	B	150A				
		C	225A	91D			
		D	400A	<b>Code</b>	<b>NEMA Enclosure Type</b>	91G	<b>Code</b>   <b>Options</b>
		E	600A	K	NEMA Type 1 or Type 1 with gasket		See Options section beginning on page 107.
		F	800A	J	NEMA Type 12		
		G	1200A				
		H	1600A				
		J	2000A				
91B							
<b>Code</b>	<b>Mounting</b>						
T <sup>[1]</sup>	Top						
B <sup>[1]</sup>	Bottom						
Z	0.5 Space Factor						

[1] A "T" or "B" is required for all 2193M units and all 400A frame and larger Bulletin 2193F units.

**Bulletin 2193F**

*3-Pole Feeder Circuit Breaker (FCB)*

- See page 61 for product description.
  - See Appendix for circuit breaker characteristics.
  - Continuous current rating based on 40°C ambient.
  - Select circuit breaker frame and trip size based upon 125% of actual load amperes. Refer to NEC/CEC. Contact your local Rockwell Automation Sales Office if 100% rated circuit breakers are required.
  - Two (2) circuit breakers with trip current up to 150 A can be dual mounted in one plug-in unit for I3C, I6C, and I0C 150A frames. I3C frame circuit breakers with current limiters also can be dual mounted but are limited to a 100A trip maximum on each circuit breaker. To specify dual mounted units, add two numbers from table on page 76 to base catalog number (e.g., 2193F-AJC-**3031CB**). Half space factor units cannot be dual-mounted.
- 2193F**—Plug-in unit, 15A-225A.  
**2193FZ**—Plug-in unit, 0.5 space factor, 15A-225A.  
**2193FT**—Top-mounted feeder, 400A are top-fed, connect load to bottom of switch.  
**2193FT**—Top-mounted feeder, 600A-1200A are reverse-fed, connect load to top of switch.  
**2193FB**—Bottom-mounted feeder, 400A-1200A are top-fed, connect load to bottom of switch.

6

92

Frame		Range of Available Trips (Amperes)	Interrupting Capacity Ratings (rms symmetrical amperes)			Space Factor	Catalog Number <sup>[1]</sup> Wiring Type A Only—Class I		Delivery Program
Rating (Amperes)	Type		208V 240V	380V 400V 415V 480V	600V		NEMA Type 1 and Type 1 w/ gasket	NEMA Type 12	
150 <sup>[2]</sup>	I3C	15-100	65k	35k	18k	0.5 <sup>[3]</sup>	2193FZ-AKC-_CB	2193FZ-AJC-_CB	SC
	I6C		100k	65k	25k		2193FZ-AKC-_CM	2193FZ-AJC-_CM	
	I0C	15-50	100k	100k	35k		2193FZ-AKC-_CX	2193FZ-AJC-_CX	
		60-100							
	I3C-CL	15-50	100k	100k	100k		2193FZ-AKC-_CD	2193FZ-AJC-_CD	
		60-100							
	I3C	125-150	65k	35k	18k		2193FZ-BKC-_CB	2193FZ-BJC-_CB	
	I6C		100k	65k	25k		2193FZ-BKC-_CM	2193FZ-BJC-_CM	
	I0C		100k	100k	35k	2193FZ-BKC-_CX	2193FZ-BJC-_CX		
	I3C-CL		100k	100k	100k	2193FZ-BKC-_CD	2193FZ-BJC-_CD		
	I3C	15-100	65k	35k	18k	1.0	2193F-AKC-_CB	2193F-AJC-_CB	
	I6C		100k	65k	25k		2193F-AKC-_CM	2193F-AJC-_CM	
	I0C	15-50	100k	100k	35k		2193F-AKC-_CX	2193F-AJC-_CX	
		60-100							
	I3C-CL	15-50	100k	100k	100k	1.0 <sup>[4]</sup>	2193F-AKC-_CD	2193F-AJC-_CD	
		60-100				1.5			
I3C	125-150 <sup>[5]</sup>	65k	35k	18k	1.0	2193F-BKC-_CB	2193F-BJC-_CB		
I6C		100k	65k	25k		2193F-BKC-_CM	2193F-BJC-_CM		
I0C		100k	100k	35k		2193F-BKC-_CX	2193F-BJC-_CX		
I3C-CL		100k	100k	100k		2193F-BKC-_CD	2193F-BJC-_CD		

[1] The catalog numbers listed are not complete:  
 • Select the trip current from table on page 76 (e.g., 2193F-AKC-**40CB**).  
 • If optional load lugs will be selected, select from table on page 76 (e.g., 2193F-AKC-40CB-**80A350**).

[2] Non-interchangeable trip breakers.  
 [3] These units have horizontal operating handles.  
 [4] When supplied with DSA (options 11DSA2 and 11DSA3), requires 1.5 space factor.  
 [5] When selecting a dual circuit breaker unit with one circuit breaker with 125A or 150A trip and the other circuit breaker with 15-100 A trip, use catalog number configuration 2193F-**B\_C**-\_\_\_\_ (e.g., 2193F-BKC-4130CB).

- See Appendix for circuit breaker characteristics.
- Continuous current rating based on 40°C ambient.
- For circuit breaker sizing, select circuit breaker frame and trip size based upon 125% of actual load amperes. Refer to NEC/CEC. Contact your local Rockwell Automation Sales Office if 100% rated circuit breakers are required.

93

Frame		Range of Available Trips (Amperes)	Interrupting Capacity Ratings (rms symmetrical amperes)			Space Factor	Catalog Number Wiring Type A Only—Class I		Delivery Program
Rating (Amperes)	Type		208V 240V	380V 400V 415V 480V	600V		NEMA Type 1 and Type 1 w/ gasket	NEMA Type 12	
225A [1]	JD3D [2]	70	65k	35k	18k	0.5 [3]	2193FZ-CKC-CT	2193FZ-CJC-CT	SC
	JD6D		100k	65k	25k		2193FZ-CKC-CM	2193FZ-CJC-CM	
	JD0D		100k	100k	35k		2193FZ-CKC-CX	2193FZ-CJC-CX	
	JD3D [2]	90-225	65k	35k	18k	1.5	2193F-CKC-CT	2193F-CJC-CT	
	JD6D		100k	65k	25k		2193F-CKC-CM	2193F-CJC-CM	
	JD0D		100k	100k	35k		2193F-CKC-CX	2193F-CJC-CX	
400 [4],[5]	K3D	125-400	65k	35k	25k	2.0	2193F-DKC-CT	2193F-DJC-CT	SC-II
	K6D		100k	65k	35k		2193F-DKC-CM	2193F-DJC-CM	
	K0D		100k	100k	65k		2193F-DKC-CX	2193F-DJC-CX	
600 [4],[5],[6]	LD	300-600	65k	35k	25k	2.0	2193F-EKC-CT	2193F-EJC-CT	
	HLD		100k	65k	35k		2193F-EKC-CM	2193F-EJC-CM	
	LDC		100k	100k	50k		2193F-EKC-CX	2193F-EJC-CX	
800 [4],[5],[6]	MDL	400-800	65k	50k	25k	2.5	2193F-FKC-CT	2193F-FJC-CT	
	HMDL		100k	65k	35k		2193F-FKC-CM	2193F-FJC-CM	
	NDC		100k	100k	65k		2193F-FKC-CX	2193F-FJC-CX	
1200 [4],[6],[7]	ND	600-1200	65k	50k	25k	3.5	2193F-GKC-CT	2193F-GJC-CT	
	HND		100k	65k	35k		2193F-GKC-CM	2193F-GJC-CM	
	NDC		100k	100k	65k		2193F-GKC-CX	2193F-GJC-CX	

6

- [1] The catalog numbers listed are not complete:
- Select the trip current from table on page 76 (e.g., 2193F-CKC-44CT).
  - If optional load lugs will be selected, select from table on page 76.
  - Then add option number to the base catalog number (e.g., 2193F-CKC-44CT-80A350).
- [2] Non-interchangeable trip breakers.
- [3] These units have horizontal operating handles.
- [4] The catalog numbers listed are not complete:
- Insert **T** for Top mounted or **B** for Bottom mounted (e.g., 2193FT- or 2193FB-).
  - Select the trip current from table on page 76 (e.g., 2193FT-DKC-50CT).
  - If optional load lugs will be selected, select from table on page 76.
  - Then add option number to the base catalog number (e.g. 2193FT-EKC-44CT-80A350).
- [5] Frame mounted unit. Must be located at top or bottom of section.
- [6] Sealed breaker and Digitrip RMS 310 electronic trip with interchangeable trip plugs.
- [7] Frame mounted unit, section does not have vertical wireway next to this unit. Must be located at top or bottom of section. May not be mounted in section containing other frame mounted units.

## Main and Feeder Units

### Bulletin 2193F

#### 3-Pole Feeder Circuit Breaker (FCB), continued

- CENTERLINE 2100 motor control centers are rated for use with 75°C wires. Wire must be sized using the 75°C column in NEC Table 310-16. The actual temperature rating of the lug is not relevant.
- Refer to Appendix for wire size conversion table.

#### Trip Current

94

Trip Current (Amperes)	Number	Trip Current (Amperes)	Number
(No breaker)	00 <sup>[1]</sup>	175	43
15	30	200	44
20	31	225	45
30	32	250	46
40	34	300	48
50	35	350	49
60	36	400	50
70	37	500	51
80	38	600	52
90	39	700	53
100	40	800	54
125	41	1000	55
150	42	1200	56

#### [1] Provision for Field Mounting

Single or dual mounted plug-in feeder units may be selected without the circuit breaker in the 150A frame size only. Add the number 00 from Trip Current table above to the base catalog number (e.g., 2193F-AKC-3500CB or 2193F-BKC-4100CB). Mounting hardware, space, and operating mechanism will be provided for future mounting of circuit breaker(s). For a single mounted feeder without circuit breaker but field mounting selected instead, the unit cost is \$310. For dual mounted units, add the \$310 for any field mounting provisions selected (e.g., 2193F-AKC-00CM is \$310; 2193F-AKC-3900CM is \$1380; \$310 + 1070 = \$1380).

#### Standard Mechanical Lugs Supplied<sup>[1]</sup>

95

Frame Type	Rating	Trip Current (Amperes)	Cables/Phase	Cable/Wire Size Range	Wire Type
I3C, I6C, I0C	150A	15-100	1	#14-#1/0 AWG	CU/AL
		125-150	1	#4-#4/0 AWG	CU
I3C-CL <sup>[2]</sup>	150A	15-70	1	#14-#2 AWG	CU/AL
		80-150	1	#1-#4/0 AWG	CU/AL
JD3D, JD6D, JD0D	225A	70-225	1	#4-350 kcmil	CU/AL
K3D, K6D, K0D	400A	125-225	1	#3-350 kcmil	CU
		250-350	1	250-500 kcmil	CU
		400	2	#3/0-250 kcmil	CU
LD, HLD, LDC	600A	300-600	2	250-350 kcmil	CU
MDL	800A	400-600	2	#2/0-500 kcmil	CU
HMDL		700-800	3	#3/0-300 kcmil	CU
NDC	800A	400-700	2	#2-500 kcmil	CU
		800	3	#3/0-500 kcmil	CU
ND, HND, NDC	1200A	600-700	2	#2/0-500 kcmil	CU
		800-1000	3	#3/0-500 kcmil	CU
		1100-1200	4	#4/0-400 kcmil	CU

[1] Lugs are designed for use with breaker frame. Standard crimp or mechanical lugs cannot be used without special lug pad assembly.

[2] No optional lugs available for I3C frame with current limiters.

#### Optional Mechanical Lugs<sup>[1]</sup>

96

Frame Type	Rating	Trip Current (Amperes)	Cables/Phase	Cable/Wire Size Range	Wire Type	Option Number
I3C, I6C, I0C	150A	15-100	1	#4-#4/0 AWG	CU/AL	-80A4X0
JD3D, JD6D, JD0D	225A	70-225	1	#4-350 kcmil	CU/AL	-80A350
K3D, K6D, K0D	400A	125-225, 400	1	250-500 kcmil	CU	-81A500
		125-225	1	#3-350 kcmil	CU/AL	-80A350
		125-350	2	#3/0-250 kcmil	CU	-81B250
		125-400	1	250-500 kcmil	CU/AL	-80A500
			2	#3/0-250 kcmil		-80B250
LD, HLD, LDC	600A	300-600	2	#3/0-350 kcmil	CU/AL	-80B350
			2	400-500 kcmil		-80B500
			2	#1-500 kcmil		CU/AL
MDL HMDL	800A	400-600	3	#3/0-300 kcmil	CU	-81C300
			400-800	2 <sup>[2]</sup>	500-750 kcmil	CU/AL
		3		#3/0-400 kcmil	-80C400	
NDC	800A	400-700	2	#1-500 kcmil	CU/AL	-80B500
		400-800	3	#3/0-400 kcmil		-80C400
ND, HND, NDC	1200A	600-700	2	#1-500 kcmil	CU/AL	-80B500
		600-1000	3	#3/0-400 kcmil		-80C400
		600-1200	4	#4/0-500 kcmil		-80D500
			3	500-750 kcmil		-80C750

[1] Lugs are designed for use with breaker frame. Standard crimp or mechanical lugs cannot be used without special lug pad assembly.

[2] Requires top entry and pullbox for 600-750 kcmil cables in order to meet UL and NEC/UL/cUL wire bending requirements. Select pullbox on page 28.

- See page 61 for product description.
- See Appendix for circuit breaker characteristics.
- Select circuit breaker frame and trip size based upon 125% of actual load amperes. Continuous current rating based on 40° C ambient. Refer to NEC/CEC.
- Mains are suitable for use as service entrance per NEC (UL) and CEC (CSA). If application is a four-wire system, a neutral plate rated for 280A is available, refer to page 25, 105, 117 and 214. If a neutral greater than 280A is required, see page 25 or 117 or contact your local Rockwell Automation Sales Office. Mains rated 1000A and above may require ground fault protection. Refer to NEC/UL/cUL.
- Main Breakers supplied with internal ground fault protection (Breaker Code CTG, CMG or CXG) are supplied with a neutral CT for use on a 3 Phase, 4 Wire, Solidly Grounded “WYE” System. Circuit breakers with internal ground fault protection are not designed for use on a Delta System, Ungrounded “WYE” System or Impedance Grounded “WYE” System.
- Mains units are frame mounted. They must be located at the top or bottom of the section.  
**2193MT**—Top-mounted main, 150A-2000A are top-fed.  
**2193MB**—Bottom-mounted main, 150A-400A are top-fed.  
**2193MB**—Bottom-mounted main, 600A-2000A are reverse-fed.
- Top- and bottom-mounted mains are designed with adequate space to route cables to lugs. Special consideration may need to be given to the mounting of the CT’s for a metering device. Addition of a pull box might be considered.
- Includes line terminal guard for JD, K, L, M, N, and R frame circuit breaker units.

97

Frame		Range of Available Trips (Amperes)	Interrupting Capacity Ratings (rms symmetrical amperes)			Space Factor	Catalog Number <sup>[1]</sup> Wiring Type A Only—Class I		Delivery Program
Rating (Ampere)	Type		208V/240V	380V/400V 415V/480V	600V		NEMA Type 1 and Type 1 w/ gasket	NEMA Type 12	
150A <sup>[2]</sup>	I3C	15-100	65k	35k	18k	1.5	2193M_-AKC_-CB	2193M_-AJC_-CB	SC-II
	I6C		100k	65k	25k		2193M_-AKC_-CM	2193M_-AJC_-CM	
	I0C	15-50	100k	100k	35k		2193M_-AKC_-CX	2193M_-AJC_-CX	
		60-100							
	I3C-CL	15-50	100k	100k	100k		2193M_-AKC_-CD	2193M_-AJC_-CD	
		60-100							
	I3C	125-150	65k	35k	18k		2193M_-BKC_-CB	2193M_-BJC_-CB	
	I6C		100k	65k	25k		2193M_-BKC_-CM	2193M_-BJC_-CM	
	I0C		100k	100k	35k		2193M_-BKC_-CX	2193M_-BJC_-CX	
	I3C-CL		100k	100k	100k		2193M_-BKC_-CD	2193M_-BJC_-CD	
100k			100k	100k					
225A	JD3D <sup>[2]</sup>	70, 90-225	65k	35k	18k	2193M_-CKC_-CT	2193M_-CJC_-CT		
	JD6D		100k	65k	25k	2193M_-CKC_-CM	2193M_-CJC_-CM		
	JD0D		100k	100k	35k	2193M_-CKC_-CX	2193M_-CJC_-CX		
400A	K3D	125- 400	65k	35k	25k	2193M_-DKC_-CT	2193M_-DJC_-CT		
	K6D		100k	65k	35k	2193M_-DKC_-CM	2193M_-DJC_-CM		
	K0D		100k	100k	65k	2193M_-DKC_-CX	2193M_-DJC_-CX		
600A	LD <sup>[3]</sup>	300-600 <sup>[4]</sup>	65k	35k	25k	2193M_-EKC_-CT	2193M_-EJC_-CT		
	LDG <sup>[3],[5]</sup>		65k	35k	25k	2193M_-EKC_-CTG	2193M_-EJC_-CTG		
	HLD <sup>[3]</sup>		100k	65k	35k	2193M_-EKC_-CM	2193M_-EJC_-CM		
	HLDG <sup>[3],[5]</sup>		100k	65k	35k	2193M_-EKC_-CMG	2193M_-EJC_-CMG		
	LDC <sup>[3]</sup>		100k	100k	50k	2193M_-EKC_-CX	2193M_-EJC_-CX		
	LDCG <sup>[3],[5]</sup>		100k	100k	50k	2193M_-EKC_-CXG	2193M_-EJC_-CXG		
	LD HI-MAG <sup>[6]</sup>		600	65k	35k	25k	2193M_-EKC-52CN	2193M_-EJC-52CN	

[1] The catalog numbers listed are not complete:

- Insert **T** for top mounted or **B** for bottom mounted (e.g., 2193MT- or 2193MB-).
- Select trip current from table on page 79 (e.g., 2193MB-AKC-**40CB**).
- If optional line lugs will be selected, select from Optional Mechanical and Crimp Lugs tables on page 80.
- Then add option number to base catalog number (e.g., 2193MB-AKC-40CB-**80A4X0**).

[2] Non-interchangeable trip breakers.

[3] Units having 100% rating are available for these circuit breakers for NEMA Type 1 and Type 1 with gasket only. See options on page 122 to select.

[4] Sealed breaker and Digitrip RMS 310 electronic trip with interchangeable trip plugs.

[5] Ground fault protection system is suited for solidly grounded system. Ground fault trip range is adjustable from 0.2 to 1 times the trip current rating of the circuit breaker rating plug. Time delay setting can be adjusted from 0.05 to 0.5 seconds. Neutral current transformer shipped loose except when option 88HN or 88FN is specified.

[6] NOT UL listed. Internal auxiliary contacts (98X, 99X) are not available on this breaker. Unit supplied with molded case switch with fixed high magnetic trip. Requires upstream current limiting branch protection. See molded case switch markings for proper selection of this protection. **Ratings listed are the maximum fault currents that can be applied to the devices.**

Bulletin 2193M

3-Pole Main Circuit Breaker (MCB), continued

6

- See page 61 for product description.
- See Appendix for circuit breaker characteristics.
- Select circuit breaker frame and trip size based upon 125% of actual load amperes. Continuous current rating based on 40° C ambient. Refer to NEC/CEC.
- Mains are suitable for use as service entrance per NEC (UL) and CEC (CSA). If application is a four-wire system, a neutral plate rated for 280A is available, refer to page 25, 105, 117 and 214. If a neutral greater than 280A is required, see page 25 or 117 or contact your local Rockwell Automation Sales Office. Mains rated 1000A and above may require ground fault protection. Refer to NEC/UL/cUL.
- Main Breakers supplied with internal ground fault protection (Breaker Code CTG, CMG or CXG) are supplied with a neutral CT for use on a 3 Phase, 4 Wire, Solidly Grounded “WYE” System. Circuit breakers with internal ground fault protection are not designed for use on a Delta System, Ungrounded “WYE” System or Impedance Grounded “WYE” System.
- Mains units are frame mounted. They must be located at the top or bottom of the section.  
**2193MT**—Top-mounted main, 150A-2000A are top-fed.  
**2193MB**—Bottom-mounted main, 150A-400A are top-fed.  
**2193MB**—Bottom-mounted main, 600A-2000A are reverse-fed.
- Top- and bottom-mounted mains are designed with adequate space to route cables to lugs. Special consideration may need to be given to the mounting of the CT’s for a metering device. Addition of a pull box might be considered.
- Includes line terminal guard for M, N, and R frame circuit breaker units.

98

Frame		Range of Available Trips (Amperes)	Interrupting Capacity Ratings (rms symmetrical amperes)			Space Factor	Catalog Number <sup>[1]</sup> Wiring Type A—Class I		Delivery Program
Rating (Amperes)	Type		208V 240V	380V, 400V, 415V, 480V	600V		NEMA Type 1 and Type 1 w/ gasket	NEMA Type 12	
800A	MDL <sup>[2]</sup>	400-800 <sup>[3]</sup>	65k	50k	25k	2.5	2193M_-FKC-_CT	2193M_-FJC-_CT	SC-II
	MDLG <sup>[2],[4]</sup>		65k	50k	25k		2193M_-FKC-_CTG	2193M_-FJC-_CTG	
	HMDL <sup>[2]</sup>		100k	65k	35k		2193M_-FKC-_CM	2193M_-FJC-_CM	
	HMDLG <sup>[2],[4]</sup>		100k	65k	35k		2193M_-FKC-_CMG	2193M_-FJC-_CMG	
	NDC <sup>[2]</sup>		100k	100k	65k		2193M_-FKC-_CX	2193M_-FJC-_CX	
	NDCG <sup>[2],[4],[5]</sup>		100k	100k	65k		2193M_-FKC-_CXG	2193M_-FJC-_CXG	
	MDL HI-MAG <sup>[6]</sup>	800	42k	35k	22k		2193M_-FKC-54CN	2193M_-FJC-54CN	
1200A	ND <sup>[2]</sup>	600-1200 <sup>[3]</sup>	65k	50k	25k	3.5 <sup>[7]</sup>	2193M_-GKC-_CT	2193M_-GJC-_CT	
	NDG <sup>[2],[4],[5]</sup>		65k	50k	25k		2193M_-GKC-_CTG	2193M_-GJC-_CTG	
	HND <sup>[2]</sup>		100k	65k	35k		2193M_-GKC-_CM	2193M_-GJC-_CM	
	HNDG <sup>[2],[4],[5]</sup>		100k	65k	35k		2193M_-GKC-_CMG	2193M_-GJC-_CMG	
	NDC <sup>[2]</sup>		100k	100k	65k		2193M_-GKC-_CX	2193M_-GJC-_CX	
	NDCG <sup>[2],[4],[5]</sup>		100k	100k	65k		2193M_-GKC-_CXG	2193M_-GJC-_CXG	
	ND HI-MAG <sup>[6]</sup>	1200	65k	50k	25k		2193M_-GKC-56CN	2193M_-GJC-56CN	
2000A	RD <sup>[2]</sup>	1200-2000 <sup>[3]</sup>	100k	65k	50k	6.0 30" W 20" D <sup>[8]</sup>	2193M_-JKC-_CM	2193M_-JJC-_CM	
	RDG <sup>[2],[4]</sup>		100k	65k	50k		2193M_-JKC-_CMG	2193M_-JJC-_CMG	

[1] The catalog numbers listed are not complete:  
 • Insert **T** for top mounted or **B** for bottom mounted (e.g., 2193MT or 2193MB).  
 • Select trip current from table on page 79 (e.g., 2193MT-AKC-40CB).  
 • If optional line lugs will be selected, select from Optional Mechanical and Crimp Lugs tables on page 80. Then add option number to the base catalog number (e.g., 2193MB-AKC-40CB-80A4X0).

[2] Units having 100% rating are available for these circuit breakers for NEMA Type 1 and Type 1 with gasket only. See options on page 122 to select.

[3] Sealed breaker and Digitrip RMS 310 electronic trip with interchangeable trip plugs.

[4] The ground fault protection system is suited for solidly grounded system. Ground fault trip range is adjustable from 0.2 to 1 times the trip current rating of the circuit breaker rating plug. The time delay setting can be adjusted from 0.05 to 0.5 seconds. Neutral current transformer supplied loose except when option 88HN or 88FN is supplied.

[5] Circuit breaker is supplied with one (1) N.O. and one (1) N.C. internal auxiliary contact, option code 98X9X must be selected to represent these auxiliary contacts.

[6] NOT UL listed. Internal auxiliary contacts (98X, 99X) are not available on this breaker. Unit supplied with molded case switch with fixed high magnetic trip. Requires upstream current limiting branch protection. See molded case switch markings for proper selection of this protection. Unfused withstand rating is 35,000A.

[7] Section does not have vertical wireway next to this unit.

[8] Section does not have vertical wireway.

- CENTERLINE 2100 motor control centers are rated for use with 75°C wire. Wire must be sized using the 75°C column in NEC/UL/cUL. The actual temperature rating of the lug is not relevant.
- Top- and bottom-mounted mains are designed with adequate space to route cables to lugs. Special consideration may need to be given to the mounting of the CT's for a metering device. Addition of a pull box might be considered.
- Refer to Appendix for wire size conversion table.

**Trip Current**

99

Trip Current (Amperes)	Number	Trip Current (Amperes)	Number
15	30	225	45
20	31	250	46
30	32	300	48
40	34	350	49
50	35	400	50
60	36	500	51
70	37	600	52
80	38	700	53
90	39	800	54
100	40	1000	55
125	41	1200	56
150	42	1600	58
175	43	2000	60
200	44	—	—

**Standard Mechanical Lugs Supplied <sup>[1]</sup>**

100

Frame Type	Rating (Amperes)	Trip Current (Amperes)	Cables/Phase <sup>[2]</sup>	Cable/Wire Size Range	Wire Type
I3C, I6C, I0C, I3C-CL	150 A	15-100 125-150	1 1	#14-#1/0 AWG #4- #4/0 AWG	CU/AL CU
JD3D, JD6D, JD0D	225 A	70-225	1	#4-350 kcmil	CU
K3D, K6D, K0D	400 A	125-225	1	#3-350 kcmil	CU
		250-350	1	250-500 kcmil	CU
		400	2	#3/0-250 kcmil	CU
LD, HLD, LDC, LDG, HLDG, LDCG	600 A	300-600	2	250-350 kcmil	CU
LD HI-MAG	600 A	600	2	250-350 kcmil	CU
MDL, MDLG HMDL, HMDLG	800 A	400-600	2	#2/0-500 kcmil	CU
		700-800	3	#3/0-300 kcmil	CU
MDL HI-MAG	800 A	800	3	#3/0-300 kcmil	CU
NDC, NDCG	800 A	400-700	2	#2/0-500 kcmil	CU
		800	3	#3/0-500 kcmil	CU
ND HI-MAG	1200 A	1200	4	#3/0-400 kcmil	CU
ND, HND, NDC, NDG, HNDG, NDCG	1200 A	600-700	2	#2/0-500 kcmil	CU
		800-1000	3	#3/0-500 kcmil	CU
		1200	4	#3/0-400 kcmil	CU
ND, HND, NDC, NDG, HNDG, NDCG—100% rated	1200 A	600-1200	4	#4/0-600 kcmil	CU/AL
RD, RDG	2000 A	1200-1600	4	#1-600 kcmil	CU
		2000	6	#2-600 kcmil	CU/AL
RD, RDG—100% rated	2000 A	1200-1600 2000	4 6	#2-600 kcmil #2-600 kcmil	CU/AL CU/AL

[1] Lugs are designed for use with breaker frame. See page 80 for additional lugs.

[2] If optional full-rated incoming neutral bus (see page 117) is specified, the quantity and size/type of the lug(s) on neutral lug pad will be the same as the 3-phase lugs. When optional half-rated incoming neutral bus (see page 117) is specified and (1) or (2) lugs per phase are specified, (1) lug will be provided on the half-rated neutral riser. When (3) or (4) lugs are specified, (2) lugs will be provided. When (5) or (6) lugs are specified, (3) lugs will be provided on half-rated neutral riser.

## Main and Feeder Units

### Bulletin 2193M

3-Pole Main Circuit Breaker (MCB), continued

#### Optional Mechanical and Crimp Lugs

101

6

MECHANICAL LUGS <sup>[1]</sup>						
Frame Type	Rating (Amperes)	Trip Current (Amperes)	Cables/Phase	Cable/Wire Size Range	Wire Type	Option Number <sup>[2]</sup>
I3C, I6C, I0C	150A	15-100	1	#4-#4/0 AWG	CU/AL	80A4X0
JD3D, JD6D, JD0D	225A	70-225	1	#4-350 kcmil	CU/AL	80A350
K3D, K6D, K0D	400A	125-225, 400	1	250-500 kcmil	CU	81A500
		125-225	1	#3-350 kcmil	CU/AL	80A350
		125-350	2	#3-250 kcmil	CU	81B250
		125-400	1	250-500 kcmil	CU/AL	80A500
			2	#3/0-250 kcmil		80B250
LD, HLD, LDC LDG, HLDG, LDCCG	600A	300-600	2	#3/0-350 kcmil 400-500 kcmil	CU/AL	80B350 80B500
MDL, MDLG HMDL, HMDLG	800A	400-600	2 <sup>[3]</sup>	#1-500 kcmil		CU/AL
		400-800 <sup>[4]</sup>	3 <sup>[3]</sup>	#3/0-300 kcmil	CU	81C300
			2	500-750 kcmil	CU/AL	80B750
NDC, NDCG	800A	400-800	3	#3/0-400 kcmil		CU/AL
		400-700	2	#1-500 kcmil	80B500	
ND, HND, NDC, NDG, HNDG, NDCG	1200A	600-700	2 <sup>[3]</sup>	#1-500 kcmil	CU/AL	80B500 <sup>[5]</sup>
		600-1000	3 <sup>[3]</sup>	#3/0-400 kcmil		80C400 <sup>[5]</sup>
		600-1200	4	#4/0-500 kcmil		80D500 <sup>[5]</sup>
			3	500-750 kcmil		80C750 <sup>[5]</sup>
ND, HND, NDC, NDG, HNDG, NDCG—(with option -755, 100% rated only)	1200A	600-1200	3 <sup>[6]</sup>	350-800 kcmil	CU/AL	80C800
RD, RDG	2000A	1200-1600	4	500-1000 kcmil	CU/AL	80D01K <sup>[5]</sup>
			6	#2-600 kcmil		80F600
CRIMP LUGS <sup>[7]</sup>						
K3D, K6D, K0D <sup>[8]</sup>	400A	125-400	2	250 kcmil	CU <sup>[9]</sup>	82B250
		125-400	1	500 kcmil	CU <sup>[9]</sup>	82A500
		125-400	2	250 kcmil	CU/AL <sup>[9]</sup>	83B250
		125-400	1	500 kcmil	CU/AL <sup>[9]</sup>	83A500
LD, HLD, LDC LDG, HLDG, LDCCG <sup>[8]</sup>	600A	300-600	2	500 kcmil	CU <sup>[9]</sup>	82B500
			2		CU/AL <sup>[9]</sup>	83B500
MDL, MDLG HMDL, HMDLG <sup>[8]</sup>	800A	400-800	3		CU <sup>[9]</sup>	82C500
			3		CU/AL <sup>[9]</sup>	83C500
NDC, NDCG <sup>[8]</sup>	800A	400-800	3		CU <sup>[9]</sup>	82C500
			3		CU/AL <sup>[9]</sup>	83C500
ND, HND, NDC, NDG, HNDG, NDCG	1200A	600-1200	4		CU <sup>[9]</sup>	82D500
			4		CU/AL <sup>[9]</sup>	83D500
RD, RDG	2000A	1200-2000	6		CU <sup>[9]</sup>	82F500
			6		CU/AL <sup>[9]</sup>	83F500

[1] Lugs are designed for use with breaker frame. Standard crimp or mechanical lugs cannot be used without optional lug pad assembly.

[2] If optional full-rated incoming neutral bus (see page 117) is specified, the quantity and size/type of the lug(s) on neutral lug pad will be the same as the 3-phase lugs. When optional half-rated incoming neutral bus (see page 117) is specified and (1) or (2) lugs per phase are specified, (1) lug will be provided on the half-rated neutral riser. When (3) or (4) lugs are specified, (2) lugs will be provided. When (5) or (6) lugs are specified, (3) lugs will be provided on half-rated neutral riser.

[3] Cannot be used on the HI-MAG frames.

[4] Requires top entry and pullbox for 600-750 kcmil cables in order to meet UL and NEC/UL/cUL wire bending requirements. Select on page 28.

[5] Not available with 2193M units with option -755 (100% rated)

[6] For top entry of incoming cables only. Requires pullbox for 750-800 kcmil cables in order to meet UL and NEC/UL/cUL cable bending requirements. Select on page 28.

[7] Breaker supplied with a lug pad assembly, reference page 215 for additional lugs.

[8] For top entry of incoming cables only. Requires pullbox. Select on page 28.

[9] CU crimp lugs are Panduit type LCC Series. CU/AL crimp lugs are Burndy YA-A Series.

# Lighting and Power Panel Units



## Bulletin 2193LE

### Lighting Panel (LPAN) ..... 82

Bulletin 2193LE is a frame mounted lighting panel with either a main lug or main circuit breaker. The lighting panels are rated for 100A or 225A with up to 42 branch circuits. One, two, and three pole bolt-on branch circuit breakers are available with ratings from 15A to 100A.

## Bulletin 2193PP

### Panel Board with Main Circuit Breaker (PPAN) ..... 84

Bulletin 2193PP is a plug-in unit panel board with main circuit breaker. The panel boards are rated for 100A, 150A, or 225A with up to 42 branch circuits. One, two, and three pole bolt-on branch circuit breakers are available with ratings from 15A to 100A.

## Lighting and Power Panel Units

### Catalog Number Explanation - Bulletin 2193LE

#### Lighting Panel (LPAN)

- Frame mounted lighting panel that is designed for field installation
- When ordered as a SC-I Unit, supplied with lighting panel, door, hardware and instructions
- Rated for 100A or 225A with a maximum 42 branch circuits
- 1, 2 or 3 pole bolt-on branch circuit breakers are available with ratings from 15 - 100A
- Reference page 219 for additional bolt-on breakers



102

7

2193LE		-	A	K	L	1	18	-	00WT	-	30A18	
Bulletin Number			Maximum Rating of Main Bus	NEMA Enclosure Type	Type of Main	System Phases	1-Pole Branch Breakers Positions		Main Breaker Trip Rating and Type Rating		Branch Breakers	
102A	<b>Code</b>	<b>Type</b>				102E	<b>Code</b>	<b>System Phases</b>	102G	<b>Code</b>	<b>Main Breaker Trip Rating and Type Rating</b>	
	2193LE	Lightning Panels with Bolt-on Branch Breakers (LPAN)					1	Single Phase		00WT	Lug Only	
				102D	<b>Code</b>	<b>Type of Main</b>		3	Three Phase	40WT	100A	
					L	Main Lug Only	102F			45WT	225A	
					B	Main Circuit Breaker		<b>Code</b>	<b>1-Pole Branch Breakers Positions</b>			
102B	<b>Code</b>	<b>Max. Rating of Main Bus</b>						15	15	102H	<b>Code</b>	<b>Branch Breakers</b>
	A	100A		102C	<b>Code</b>	<b>NEMA Enclosure Type</b>		16	16		See Factory - Installed Bolt-On Branch Breaker table on Page 83	
	C	225A			K	NEMA Type 1 or Type 1 with gasket		18	18			
					J	NEMA Type 12		27	27			
								30	30			
								42	42			

Frame Mounted Lighting Panel for Bolt-on Branch Circuit Breakers (LPAN)

- See page 81 for product description.
- Units are NOT wired. Units have NO plug-in stabs.
- Load terminal blocks are NOT furnished.
- Lighting panel bus is aluminum with tin plating. Directory card is supplied.

103

7

Type	Panel Bus and Main Lug Ampere Rating	Max. Number of 1-pole Circuit Breakers	Space Factor	Catalog Number Wiring Type A—Class I (Catalog numbers do not include branch breakers. Refer to Factory-Installed Bolt-On Branch Circuit Breakers table below for catalog string numbers.)		Delivery Program
				NEMA Type 1 and Type 1 w/ gasket	NEMA Type 12	
<b>WITH MAIN LUG ONLY (MLO)</b>						
Single Phase 3-Wire 120/240 Volts AC 10kA IC rms Sym.	100	18	2.0	2193LE-AKL118-00WT	2193LE-AJL118-00WT	SC
	225	30	2.5	2193LE-CKL130-00WT	2193LE-CJL130-00WT	
		42	3.0	2193LE-CKL142-00WT	2193LE-CJL142-00WT	
Three Phase 4-Wire 120/208 Volts AC 10kA IC rms Sym.	100	18	2.0	2193LE-AKL318-00WT	2193LE-AJL318-00WT	
		30	2.5	2193LE-AKL330-00WT	2193LE-AJL330-00WT	
	225	42	3.0	2193LE-CKL342-00WT	2193LE-CJL342-00WT	
<b>WITH MAIN CIRCUIT BREAKER (MCB) <sup>[1]</sup></b> 100A Main Circuit Breaker is Cutler-Hammer BAB type series rating 10kA. 225A Main Circuit Breaker is Cutler-Hammer ED type series rating 65kA.						
Single Phase 3-Wire 120/240 Volts AC.	100 <sup>[1]</sup>	16	2.0	2193LE-AKB116-40WT	2193LE-AJB116-40WT	SC
	225	30	3.5	2193LE-CKB130-45WT	2193LE-CJB130-45WT	
		42	4.0	2193LE-CKB142-45WT	2193LE-CJB142-45WT	
Three Phase 4-Wire 120/208 Volts AC.	100 <sup>[1]</sup>	15	2.0	2193LE-AKB315-40WT	2193LE-AJB315-40WT	
		27	2.5	2193LE-AKB327-40WT	2193LE-AJB327-40WT	
	225	42	4.0	2193LE-CKB342-45WT	2193LE-CJB342-45WT	

[1] The 100A main circuit breaker in a 100A lighting panel is a reverse-fed branch lighting panel circuit breaker.

**Factory-Installed Bolt-On Branch Circuit Breakers \***

104

1-Pole Thermal Magnetic 120V AC Circuit Breaker 10kA IC Sym		2-Pole Thermal Magnetic 120/240V AC Circuit Breaker 10kA IC Sym		3-Pole Thermal Magnetic 120/240V AC Circuit Breaker 10kA IC Sym (for use on three phase lighting panels only)	
Trip Rating @ 40° C (Amperes)	Catalog String Number <sup>[1]</sup>	Trip Rating @ 40° C (Amperes)	Catalog String Number <sup>[1]</sup>	Trip Rating @ 40° C (Amperes)	Catalog String Number <sup>[1]</sup>
15A	30A__	15A	30B__	15A	30C__
20A	31A__	20A	31B__	20A	31C__
30A	32A__	30A	32B__	30A	32C__
15A w/ grd flt <sup>[2]</sup>	30D__	50A	35B__	50A	35C__
20A w/ grd flt <sup>[2]</sup>	31D__	100A	40B__	100A	40C__
Filler Plate	00A__	—	—	—	—

- [1] The catalog numbers listed are not complete:
- Select the number of branch breakers (e.g., 32A18).
  - Add two digits to specify the number of branch breakers desired. Two digits are required for quantities less than ten (e.g., 03 for quantity three).
  - When selecting multiple branch breakers with different trip ratings, add additional string numbers to the end of the catalog number (e.g., 2193LE-AKL318-00WT-30A08-31B02-30C02).
  - Locations of the branch breakers are determined by the factory.
  - The maximum amperes connected to any one connector cannot exceed 200A on bolt-on branch breakers. All branch breakers are Type BAB.
- [2] Ground fault interrupting circuit breakers provide 5mA personnel protection.

\* Refer to page 219 for catalog numbers for field installed branch breakers. When breakers are to be factory-installed, specify filler plates for all remaining blank spaces in panel.

## Lighting and Power Panel Units

### Catalog Number Explanation - Bulletin 2193PP Panel Board with Main Circuit Breaker (PPAN)

- Plug-in unit panel board
- Rated for 100A, 150A, or 225A with up to 42 branch circuits
- 1, 2 or 3 pole bolt-on branch circuit breakers available with ratings from 15A - 100A
- Reference page 219 for additional bolt-on breakers

105

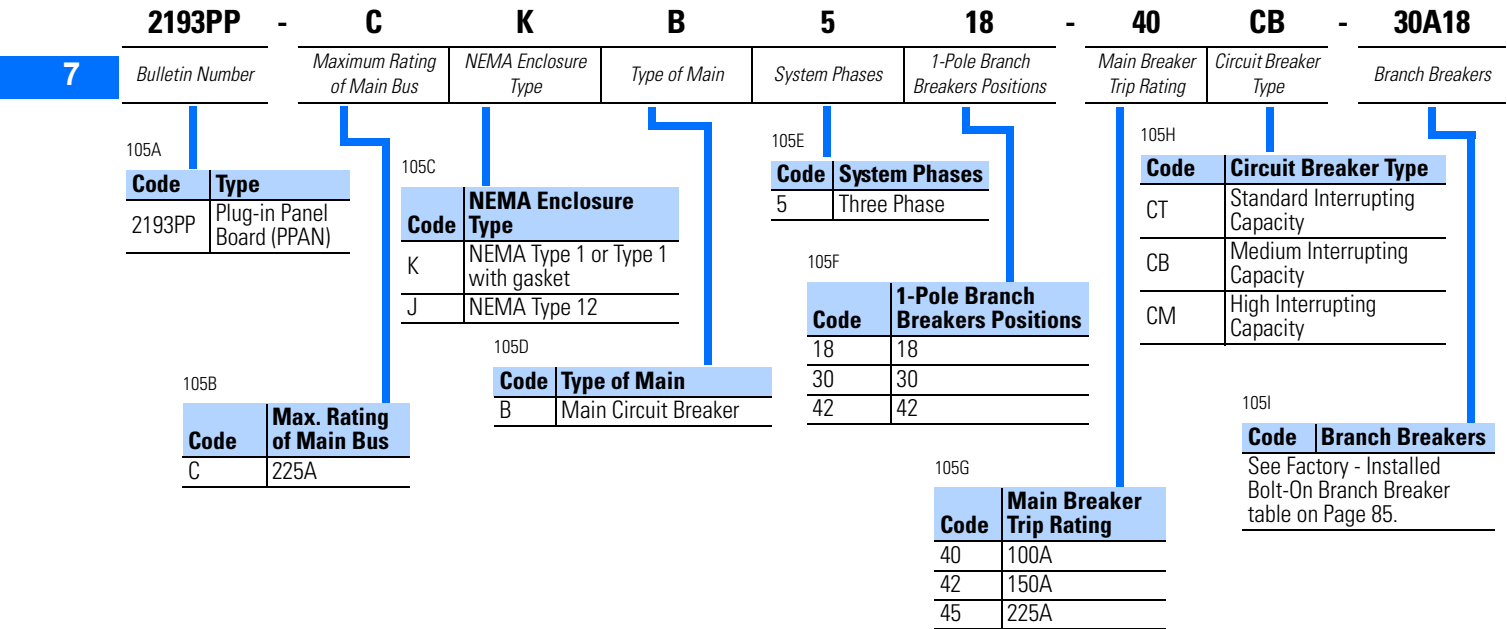

- See page 81 for product description.
  - Unit plugs into the MCC vertical bus.
  - The panel board bus is aluminum with tin plating.
  - **The panel board is series rated.** The interrupting capacity rating shown can be applied to all branch circuit breakers.
  - Bulletin 2193PP panel board is suitable for use with 3-phase, 4-wire, solidly grounded, Wye systems rated 480Y/277V or less. May also be used on solidly grounded 3-wire power systems, however, only 2-pole and 3-pole branch circuit breakers can be used.
- NOTE:** Neutral and ground bar in Bulletin 2193PP will not be factory connected to any neutral bus, neutral plate or ground bus.

106

7

Main Breaker Trip Rating (Amperes)	Max. Number of 1-pole Circuit Breakers	Main Circuit Breaker Type	Space Factor	IC Rating at 480Y/277V (rms Sym.) (This rating can be applied to all branch circuit breakers.)	Catalog Number <sup>[1]</sup> Wiring Type A—Class I		Delivery Program
					NEMA Type 1 and Type 1 w/ gasket	NEMA Type 12	
<b>WITH MAIN CIRCUIT BREAKER (MCB)</b>							
100	18	I3C	2.5	25kA	2193PP-CKB518-40CB-__	2193PP-CJB518-40CB-__	PE
		I6C		65kA	2193PP-CKB518-40CM-__	2193PP-CJB518-40CM-__	
		IOC <sup>[2]</sup>		100kA	2193PP-CKB518-40CX-__	2193PP-CJB518-40CX-__	
150	30	I3C	3.0	25kA	2193PP-CKB530-42CB-__	2193PP-CJB530-42CB-__	
		I6C		65kA	2193PP-CKB530-42CM-__	2193PP-CJB530-42CM-__	
		IOC <sup>[2]</sup>		100kA	2193PP-CKB530-42CX-__	2193PP-CJB530-42CX-__	
150	42	I3C	3.5	25kA	2193PP-CKB542-42CB-__	2193PP-CJB542-42CB-__	
		I6C		65kA	2193PP-CKB542-42CM-__	2193PP-CJB542-42CM-__	
		IOC <sup>[2]</sup>		100kA	2193PP-CKB542-42CX-__	2193PP-CJB542-42CX-__	
225	18	JD3D <sup>[3]</sup>	3.5	35kA <sup>[4]</sup>	2193PP-CKB518-45CT-__	2193PP-CJB518-45CT-__	
	30		3.5	35kA <sup>[4]</sup>	2193PP-CKB530-45CT-__	2193PP-CJB530-45CT-__	
	42		4.0	35kA <sup>[4]</sup>	2193PP-CKB542-45CT-__	2193PP-CJB542-45CT-__	

- [1] The catalog numbers listed are not complete:
- Select the appropriate catalog string number from Factory-Installed Bolt-On Branch Breaker table below to identify the branch breaker trip rating.
  - Add two digits to specify the number of branch breakers desired. Two digits are also required for quantities less than ten (e.g., 03 for quantity three—2193PP-CKB530-42CX-32A03).
  - When selecting multiple branch breakers with different trip ratings, add additional string numbers to the end of the catalog number (e.g., 2193PP-CKB518-40CB-30A08-31B02-30C02).
  - Locations of the branch breakers are determined by the factory.
- [2] PE delivery program in Canada, Engineered delivery program in U.S. Contact your local Rockwell Automation Sales Office for availability.
- [3] Non-interchangeable trip breakers.
- [4] 35kA series combination rating only when used with 50 A or lower rated branch circuit breakers. Series combination rating is 22kA when used with branch circuit breakers rated 60 A or higher.

**Factory-Installed Bolt-On Branch Breaker \***

107

1-Pole Inverse Time (Thermal Magnetic) 277VAC Circuit Breaker 14kA I.C. SYM		2-Pole Inverse Time (Thermal Magnetic) 480Y/277VAC Circuit Breaker 14kA I.C. SYM		3-Pole Inverse Time (Thermal Magnetic) 480Y/277VAC Circuit Breaker 14kA I.C. SYM		Delivery Program	
Trip Rating @ 40° C (Amperes)	Catalog String Number	Trip Rating @ 40° C (Amperes)	Catalog String Number	Trip Rating @ 40° C (Amperes)	Catalog String Number		
15	30A__	15	30B__	15	30C__	PE	
20	31A__	20	31B__	20	31C__		
25	61A__	25	61B__	25	61C__		
30	32A__	30	32B__	30	32C__		
35	33A__	35	33B__	35	33C__		
40	34A__	40	34B__	40	34C__		
50	35A__	50	35B__	50	35C__		
60	36A__	60	36B__	60	36C__		
70	37A__	70	37B__	70	37C__		
80	38A__	80	38B__	80	38C__		
90	39A__	90	39B__	90	39C__		
100	40A__	100	40B__	100	40C__		
Filler Plate	00A__	—	—	—	—		SC

\* All branch breakers are Type GHB. Refer to page 219 for catalog number of field installed branch breakers. Specify filler plates for all blank spaces in panel. The maximum amperes connected to any one connector cannot exceed 200A. The 14kA interrupting capacity rating applies to the individual branch breaker. When used in the 2193PP, the I.C. rating of the main breaker can be applied to all branch breakers.



# Transformer Units

## Bulletin 2195, 2196, 2197

### Control and Lighting Transformers (XFMR) ..... 88

Bulletins 2195, 2196, and 2197 are control and lighting transformer units. The transformer units are available with ratings from 0.5 kVA through 50 kVA for single-phase and 10 kVA through 45 kVA for three-phase. Secondary fuses are provided with each transformer unit. Factory installed primary fusing is optional on the 2196 transformer unit.

## Transformer Units

### Catalog Number Explanation - Bulletin 2195, 2196 and 2197

#### Transformer Units

- Control and lighting transformers
- Rated from 0.5 kVA - 50 kVA, single-phase and 10 kVA - 45 kVA, three-phase
- Secondary protection provided

108

<b>2195</b>	-	<b>A</b>	<b>K</b>	<b>BD</b>	-		-	<b>**</b>
<b>2196</b>	-	<b>A</b>	<b>K</b>	<b>BD</b>	-	<b>24J</b>	-	<b>**</b>
<b>2197</b>	-	<b>A</b>	<b>K</b>	<b>BD</b>	-	<b>30CB</b>	-	<b>**</b>
<i>Bulletin Number</i>		<i>Transformer Size</i>	<i>NEMA Enclosure Type</i>	<i>Line Voltage</i>		<i>Fuse, Clip Rating and Class or Circuit Breaker Trip and Type</i>		<i>Options</i>

8

108A

Code	Type
2195	Control and Lighting Transformer without Disconnecting Means (XFMR)
2196(Z)	Control and Lighting Transformer with Fusible Disconnect (XFMR)
2197(Z)	Control and Lighting Transformer with Circuit Breaker (XFMR)

**Note:** The (Z) denotes that the disconnect portion of the unit is 0.5 space factor.

108C

Code	NEMA Enclosure Type
K	NEMA Type 1 or Type 1 with gasket
J	NEMA Type 12

108E

Code	Fuse, Clip Rating and Class or Circuit Breaker Trip and Type
2195	Not Applicable
2196	"24J" Fuse Clip Rating and Class. See table on Page 209
2197	"30CB" Circuit Breaker Trip and Type. See table on Page 209 and 211

108B

Code	Transformer Size
Single Phase	
A	0.5 kVA
B	0.75 kVA
C	1.0 kVA
Z	1.6 kVA
E	2.0 kVA
F	3.0 kVA
G	5.0 kVA
H	7.5 kVA
J	10 kVA
K	15 kVA
M	25 kVA
X	37.5 kVA
Y	50 kVA
Three Phase	
P	10 kVA
Q	15 kVA
S	25 kVA
T	30 kVA
V	37.5 kVA
W	45 kVA

108D

Line Voltage		
Single Phase		
Code	Primary	Secondary
AD	240 V	120 V, (1) Fuse
BD	480 V 0 V	120 V, (1) Fuse
CD	600 V	120 V, (1) Fuse
AA	240 V	240/120 V, (2) Fuses
BA	480 V	240/120 V, (2) Fuses
CA	600 V	240/120 V, (2) Fuses
NS	380 V	110/115 V, (1) 1-pole CB
KNS	400 V	110/115 V, (1) 1-pole CB
IS	415 V	110/115 V, (1) 1-pole CB
NP	380 V	110 V, (2) 1-pole CB
KNP	400 V	115 V, (2) 1-pole CB
IP	415 V	220 V, (2) 1-pole CB
IT	415 V	240 V, (2) 1-pole CB
Three Phase		
Code	Primary	Secondary
AH	240 V	208/120 V, (3) Fuses
BH	480 V	208/120 V, (3) Fuses
CH	600 V	208/120 V, (3) Fuses

108F

Code	Options
	See Options Section beginning on Page 107

See 87 for product description.

**NOTE:** Do not mount transformer units below drive units. Heat from transformer units may cause drive to trip.

**NOTE:** In order to address the heating effects from loads containing a high degree of harmonic content, it may be necessary to oversize the field conductors (especially neutrals), use k-factor lighting transformers, and oversize the lighting contactor units (increase by 50%). Contact your local Rockwell Automation Sales Office.

**NOTE:** Tap arrangement for 15-50kVA single phase transformers is (2) 2-1/2% Taps FCAN, (4) 2-1/2% Taps FCBN.

Tap arrangements for 10-45 kVA three phase transformers is (2) 2-1/ 2% Taps FCBN.

**NOTE:** Transformers have Class 180°C insulation, 80° C rise.

For 71" high sections, see restrictions on page 24.

Rating kVA <sup>[1]</sup>	Recommended Primary Protection (Amperes)			Space Factor	Catalog Number <sup>[2]</sup> Wiring Type A—Class I			Delivery Program	
	240 V	480 V	600 V		NEMA Type 1 and Type 1 w/ gasket <sup>[3]</sup>	NEMA Type 1 with filters and Type 1 w/ gasket and filters <sup>[4]</sup>	NEMA Type 12 <sup>[1]</sup>		
<b>SINGLE PHASE—120 Volt secondary with one (1) secondary fuse</b>									
0.5	15	15	15	1.0	2195-AK_D	—	2195-AJ_D	[5]	
0.75					2195-BK_D	—	2195-BJ_D		
1					2195-CK_D	—	2195-CJ_D		
1.6					2.0	2195-ZK_D	—		2195-ZJ_D
2						2195-EK_D	—		2195-EJ_D
3 (1.5)					1.5 <sup>[6]</sup>	2195-FK_D	2195-FK_D-16A		2195-FJ_D
5 (2.5)	1.5 <sup>[6]</sup>	2195-GK_D	2195-GK_D-16A	2195-GJ_D					
<b>SINGLE PHASE—120/240 Volt secondary with two (2) secondary fuses</b> Transformer secondary wired and protected for 240 V phase to phase/120 V phase to center tap neutral.									
5 (2.5)	30	15	—	1.5 <sup>[6]</sup>	2195-GK_A	2195-GK_A-16A	2195-GJ_A	[7]	
7.5 (3.7)	40	20	20		2195-HK_A	2195-HK_A-16A	2195-HJ_A		
10 (5)	50	30	20		2195-JK_A	2195-JK_A-16A	2195-JJ_A		
15 (7.5)	70	40	30	2.0 <sup>[8]</sup>	2195-KK_A	2195-KK_A-16A	2195-KJ_A		
25 (12.5)	125	70	60		2195-MK_A	2195-MK_A-16A	2195-MJ_A		
37.5 (18.5)	200	100	70	2.0	2195-XK_A	2195-XK_A-16A	2195-XJ_A		
50 (25)	300	150	100	20" D <sup>[8]</sup>	2195-YK_A	2195-YK_A-16A	2195-YJ_A		
<b>THREE PHASE—120/208 Volt secondary with three (3) secondary fuses</b> Transformer secondary wired and protected for 208 V phase to phase/120 V phase to WYE neutral.									
10 (5)	—	20	15	2.0 <sup>[8]</sup>	2195-PK_H	2195-PK_H-16A	2195-PJ_H	[7]	
15 (7.5)	—	20	15		2195-QK_H	2195-QK_H-16A	2195-QJ_H		
25 (12.5)	—	40	30		2195-SK_H	2195-SK_H-16A	2195-SJ_H		
30 (15)	—	50	40		2195-TK_H	2195-TK_H-16A	2195-TJ_H		
37.5 (18.5)	—	60	50	2.0	2195-VK_H	2195-VK_H-16A	2195-VJ_H		
45 (22.5)	—	70	60	20" D <sup>[8]</sup>	2195-WK_H	2195-WK_H-16A	2195-WJ_H		

[1] In NEMA Type 12 applications (non-ventilated 3kVA and larger transformers), to maximize the transformer's life, it is recommended that the transformer not be loaded to greater than 50% of its nameplate rating. Number in parentheses indicates approximate derated rating. However, in many applications, NEMA Type 1 with gasket design (vented and filtered doors) may be sufficient.

[2] The catalog numbers listed are not complete. Select the primary voltage code from table on page 205 to identify the transformer primary voltage desired (e.g., 2195-FKBD).

[3] For ratings 3kVA and larger, vented door is provided.

[4] For ratings 3kVA and larger, vented and filtered door is provided. 3kVA and larger are available on NEMA Type 12 structures but unit still will be NEMA Type 1/1G with gasket and filters. See page 114 for option -16A.

[5] 240 V and 480 V are SC in U.S. and Canada. 600 V is PE in U.S. and SC in Canada.

[6] Frame mounted unit. Must be located at bottom of section.

[7] 240 V and 480 V are SC-II in U.S. and Canada. 600 V is PE-II in U.S. and SC-II in Canada.

[8] Frame mounted unit, section does not have vertical wireway next to this unit. Must be located at bottom of section.

## Transformer Units

### Bulletin 2195

#### Control and Lighting Transformer Unit without Disconnecting Means (XFMR), continued

See 87 for product description.

**NOTE:** Do not mount transformer units below drive units. Heat from transformer units may cause drive to trip.

**NOTE:** In order to address the heating effects from loads containing a high degree of harmonic content, it may be necessary to oversize the field conductors (especially neutrals), use k-factor lighting transformers, and oversize the lighting contactor units (increase by 50%). Contact your local Rockwell Automation Sales Office.

**NOTE:** Transformers have Class 180°C insulation, 80°C rise.

For 71" high sections, see restrictions on page 24.

110

8

Rating kVA <sup>[1]</sup>	Recommended Primary Protection (Amperes)			Space Factor	Catalog Number Wiring Type A—Class I			Delivery Program	
	380 V	400 V	415 V		NEMA Type 1 and Type 1 w/ gasket <sup>[2]</sup>	NEMA Type 1 with filters and Type 1 w/ gasket and filters <sup>[3]</sup>	NEMA Type 12 <sup>[1]</sup>		
<b>SINGLE PHASE—110/115 Volt secondary with one (1) 1-pole circuit breaker <sup>[4]</sup></b>									
0.5 <sup>[4]</sup>	15	15	15	1.0	2195-AK_S <sup>[5]</sup>	—	2195-AJ_S <sup>[5]</sup>	PE	
0.75 <sup>[4]</sup>					2195-BK_S <sup>[5]</sup>	—	2195-BJ_S <sup>[5]</sup>		
1 <sup>[4]</sup>					2195-CK_S <sup>[5]</sup>	—	2195-CJ_S <sup>[5]</sup>		
1.6 <sup>[4]</sup>					2.0	2195-ZK_S <sup>[5]</sup>	—		2195-ZJ_S <sup>[5]</sup>
2 <sup>[4]</sup>						2195-EK_S <sup>[5]</sup>	—		2195-EJ_S <sup>[5]</sup>
3 <sup>[4]</sup> (1.5)				1.5 <sup>[6]</sup>	2195-FK_S <sup>[5]</sup>	2195-FK_S-16A <sup>[5]</sup>	2195-FJ_S <sup>[5]</sup>		PE-II
<b>SINGLE PHASE—110/220, Volt secondary with two (2) 1-pole circuit breakers</b> Transformer secondary wired and protected for 220 V phase-to-phase, 110 V phase-to-center tap neutral.									
5 (2.5) <sup>[4]</sup>	20	—	—	1.5 <sup>[6]</sup>	2195-GKNP	2195-GKNP-16A	2195-GJNP	PE-II	
7.5 (3.7) <sup>[4]</sup>	20	—	—		2195-HKNP	2195-HKNP-16A	2195-HJNP		
10 (5) <sup>[4]</sup>	30	—	—		2195-JKNP	2195-JKNP-16A	2195-JJNP		
15 (7.5)	50	—	—	2.0 <sup>[7]</sup>	2195-KKNP	2195-KKNP-16A	2195-KJNP		
<b>SINGLE PHASE—115/230 Volt secondary with two (2) 1-pole circuit breakers</b> Transformer secondary wired and protected for 230 V phase-to-phase, 115 V phase-to-center tap neutral.									
5 (2.5)	—	20	—	1.5 <sup>[6]</sup>	2195-GKKNP	2195-GKKNP-16A	2195-GJKNP	PE-II	
7.5 (3.7)	—	20	—		2195-HKKNP	2195-HKKNP-16A	2195-HJKNP		
10 (5)	—	30	—		2195-JKKNP	2195-JKKNP-16A	2195-JJKNP		
<b>SINGLE PHASE—120/240 Volt secondary with two (2) 1-pole circuit breakers <sup>[8]</sup></b> Transformer secondary wired and protected for 240 V phase-to-phase, 120 V phase-to-center tap neutral.									
5 (2.5) <sup>[4]</sup>	—	—	20	1.5 <sup>[6]</sup>	2195-GKIT	2195-GKIT-16A	2195-GJIT	PE-II	
7.5 (3.7) <sup>[4]</sup>	—	—	20		2195-HKIT	2195-HKIT-16A	2195-HJIT		
10 (5) <sup>[4]</sup>	—	—	30		2195-JKIT	2195-JKIT-16A	2195-JJIT		
15 (7.5) <sup>[9]</sup>	—	—	50	2.0 <sup>[7]</sup>	2195-KKIP	2195-KKIP-16A	2195-KJIP		

[1] In NEMA Type 12 applications (non-ventilated 3kVA and larger transformers), to maximize the transformer's life, it is recommended that the transformer not be loaded to greater than 50% of its nameplate rating. Number in parentheses indicates approximate derated rating. However, in many applications, NEMA Type 1 with gasket design (vented and filtered doors) may be sufficient.

[2] For ratings 3kVA and larger, vented door is provided.

[3] For ratings 3kVA and larger, vented and filtered door is provided. 3kVA and larger are available on NEMA Type 12 structures but unit still will be NEMA Type 1/1G with gasket and filters. See page 114 for option -16A.

[4] Incorporates primary taps for future conversion to new global IEC voltage standards (e.g., 400 V/115 V/230 V). Allows conversion without the need to replace transformers.

[5] The catalog numbers listed are not complete. Select the primary voltage code from table on page 205 to identify the transformer primary voltage desired (e.g., 2195-FKNS).

[6] Frame mounted unit. Must be located at bottom of section.

[7] Frame mounted unit, section does not have vertical wireway next to this unit. Must be located at bottom of section.

[8] The 15kVA transformer has 110/220 Volt secondary with two (2) 1-pole circuit breakers.

[9] Tap arrangement is (2) 2-1/2% Taps FCAN, (4) 2-1/2% Taps FCBN.

See 87 for product description.

**NOTE:** Do not mount transformer units below drive units. Heat from transformer units may cause drive to trip.

**NOTE:** In order to address the heating effects from loads containing a high degree of harmonic content, it may be necessary to oversize the field conductors (especially neutrals), use k-factor lighting transformers, and oversize the lighting contactor units (increase by 50%). Contact your local Rockwell Automation Sales Office.

**NOTE:** Transformers have Class 180°C insulation, 80°C rise.

**NOTE:** Tap arrangement for 15-50kVA single phase transformers is (2) 2-1/2% Taps FCAN, (4) 2-1/2% Taps FCBN.

Tap arrangements for 10-45 kVA three phase transformers is (2) 2-1/ 2% Taps FCBN.

**NOTE:** 3 through 50 kVA consists of two (2) compartments—a fusible disconnect compartment and a transformer compartment wired and interlocked together.

For 71" high sections, see restrictions on page 24.

111

Rating kVA <sup>[1]</sup>	Fuse Clip Rating (Amperes)			Space Factor	Catalog Number <sup>[2]</sup> Wiring Type A—Class I			Delivery Program
	240 V	480 V	600 V		NEMA Type 1 and Type 1 w/ gasket <sup>[3]</sup>	NEMA Type 1 with filters and Type 1 w/ gasket and filters <sup>[4]</sup>	NEMA Type 12 <sup>[1]</sup>	
<b>SINGLE PHASE—120 Volt secondary with one (1) secondary fuse</b>								
0.5	30	30	30	1.0	2196-AK_D-__	—	2196-AJ_D-__	[5]
0.75				2196-BK_D-__	—	2196-BJ_D-__		
1				2196-CK_D-__	—	2196-CJ_D-__		
1.6				2196-ZK_D-__	—	2196-ZJ_D-__		
2				2196-EK_D-__	—	2196-EJ_D-__		
3 (1.5)	—	—	30	2.5 <sup>[6]</sup>	2196-FK_D-__	2196-FK_D-__-16A	2196-FJ_D-__	[7]
5 (2.5)	—	—	30	2.5 <sup>[6]</sup>	2196-GK_D-__	2196-GK_D-__-16A	2196-GJ_D-__	
<b>SINGLE PHASE—120/240 Volt secondary with two (2) secondary fuses</b>								
Transformer secondary wired and protected for 240 V phase to phase/120 V phase to center tap neutral.								
5 (2.5)	30	30	—	2.5 <sup>[6]</sup>	2196-GK_A-__	2196-GK_A-__-16A	2196-GJ_A-__	[7]
7.5 (3.7)	60	30	30		2196-HK_A-__	2196-HK_A-__-16A	2196-HJ_A-__	
10 (5)	60	30	30		2196-JK_A-__	2196-JK_A-__-16A	2196-JJ_A-__	
15 (7.5)	100	60	60	3.0 <sup>[8],[9]</sup>	2196-KK_A-__	2196-KK_A-__-16A	2196-KJ_A-__	
25 (12.5)	200	60	60	3.0 <sup>[8],[9]</sup>	2196-MK_A-__	2196-MK_A-__-16A	2196-MJ_A-__	
37.5 (18.5)	200	100	100	3.5 20" D <sup>[8],[9]</sup>	2196-XK_A-__	2196-XK_A-__-16A	2196-XJ_A-__	
50 (25)	—	200	100	3.5, 20" D <sup>[9],[10]</sup>	2196-YK_A-__	2196-YK_A-__-16A	2196-YJ_A-__	
<b>THREE PHASE—120/208 Volt secondary with three (3) secondary fuses</b>								
Transformer secondary wired and protected for 280 V phase to phase/120 V phase to WYE neutral.								
10 (5)	—	30	30	3.0 <sup>[9]</sup>	2196-PK_H-__	2196-PK_H-__-16A	2196-PJ_H-__	[7]
15 (7.5)	—	30	30		2196-QK_H-__	2196-QK_H-__-16A	2196-QJ_H-__	
25 (12.5)	—	60	60		2196-SK_H-__	2196-SK_H-__-16A	2196-SJ_H-__	
30 (15)	—	60	60		2196-TK_H-__	2196-TK_H-__-16A	2196-TJ_H-__	
37.5 (18.5)	—	60	60	3.0 20" D <sup>[9]</sup>	2196-VK_H-__	2196-VK_H-__-16A	2196-VJ_H-__	
45 (22.5)	—	100	60	3.0 20" D <sup>[9],[10]</sup>	2196-WK_H-__	2196-WK_H-__-16A	2196-WJ_H-__	

[1] In NEMA Type 12 applications (non-ventilated 3kVA and larger transformers), to maximize the transformer's life, it is recommended that the transformer not be loaded to greater than 50% of its nameplate rating. Number in parentheses indicates approximate derated rating. However, in many applications, NEMA Type 1 with gasket design (vented and filtered doors) may be sufficient.

[2] The catalog numbers listed are not complete. Select the voltage code from table on page 205 (e.g., 2196-FKBD).

- If power fuse will NOT be selected, select fuse clip designator from table on page 209 (e.g., 2196-FKBD-24J).
- If power fuse WILL be selected, select the fuse clip designator AND the manufacturer from table on page 209 (e.g., 2196-FKBD-24JG).
- For fuse rating, based on transformer rating, see publication 2100-TD003x-EN-P.

[3] For ratings 3kVA and larger, vented door is provided.

[4] For ratings 3kVA and larger, vented and filtered door is provided. 3kVA and larger are available on NEMA Type 12 structures but unit still will be NEMA Type 1/1G with gasket and filters. See page 114 for option -16A.

[5] 240 V and 480 V are SC in U.S. and Canada. 600 V is PE in U.S. and SC in Canada.

[6] Frame mounted unit. Must be located at bottom of section.

[7] 240 V and 480 V are SC-II in U.S. and PE-II in Canada. 600 V is PE-II in U.S. and SC-II in Canada.

[8] For transformers with 240 volt primary, add 0.5 space factor.

[9] Frame mounted unit, section does not have vertical wireway next to this unit. Must be located at bottom of section.

[10] For transformers with 480 volt primary, add 0.5 space factor.

## Transformer Units

### Bulletin 2196Z\*

#### Control and Lighting Transformer Unit with Fusible Disconnect Switch (XFMR)

See 87 for product description.

**NOTE:** Do not mount transformer units below drive units. Heat from transformer units may cause drive to trip.

**NOTE:** In order to address the heating effects from loads containing a high degree of harmonic content, it may be necessary to oversize the field conductors (especially neutrals), use k-factor lighting transformers, and oversize the lighting contactor units (increase by 50%). Contact your local Rockwell Automation Sales Office.

**NOTE:** Tap arrangement for 15-50kVA single phase transformers is (2) 2-1/2% Taps FCAN, (4) 2-1/2% Taps FCBN.

Tap arrangements for 10-45 kVA three phase transformers is (2) 2 1/ 2% Taps FCBN.

**NOTE:** Transformers have Class 180°C insulation, 80°C rise.

**NOTE:** Unit consists of two (2) compartments—a fusible disconnect compartment and a transformer compartment wired and interlocked together. The fusible disconnect compartment has a horizontal operating handle.

For 71" high sections, see restrictions on page 24.

112

8

Rating kVA <sup>[1]</sup>	Fuse Clip Rating (Amperes)			Space Factor	Catalog Number <sup>[2]</sup> Wiring Type A—Class I			Delivery Program
	240 V	480 V	600 V		NEMA Type 1 and Type 1 w/ gasket <sup>[3]</sup>	NEMA Type 1 with filters and Type 1 w/ gasket and filters <sup>[4]</sup>	NEMA Type 12 <sup>[1]</sup>	
<b>SINGLE PHASE—120 Volt secondary with one (1) secondary fuse</b>								
3 (1.5)	30	30	30	2.0 <sup>[5]</sup>	2196Z-FK_D-__	2196Z-FK_D-__-16A	2196Z-FJ_D-__	[6]
5 (2.5)	—	—	30	2.0 <sup>[5]</sup>	2196Z-GK_D-__	2196Z-GK_D-__-16A	2196Z-GJ_D-__	
<b>SINGLE PHASE—120/240 Volt secondary with two (2) secondary fuses</b> Transformer secondary wired and protected for 240 V phase to phase/120 V phase to center tap neutral.								
5 (2.5)	30	30	—	2.0 <sup>[5]</sup>	2196Z-GK_A-__	2196Z-GK_A-__-16A	2196Z-GJ_A-__	[6]
7.5 (3.7)	—	30	30		2196Z-HK_A-__	2196Z-HK_A-__-16A	2196Z-HJ_A-__	
10 (5)	—	30	30		2196Z-JK_A-__	2196Z-JK_A-__-16A	2196Z-JJ_A-__	
<b>THREE PHASE—120/208 Volt secondary with three (3) secondary fuses</b> Transformer secondary wired and protected for 280 V phase to phase/120 V phase to WYE neutral.								
10 (5)	—	30	30	2.5 <sup>[7]</sup>	2196Z-PK_H-__	2196Z-PK_H-__-16A	2196Z-PJ_H-__	[6]
15 (7.5)	—	30	30		2196Z-QK_H-__	2196Z-QK_H-__-16A	2196Z-QJ_H-__	

[1] In NEMA Type 12 applications (non-ventilated 3kVA and larger transformers), to maximize the transformer's life, it is recommended that the transformer not be loaded to greater than 50% of its nameplate rating. Number in parentheses indicates approximate derated rating. However, in many applications, NEMA Type 1 with gasket design (vented and filtered doors) may be sufficient.

[2] The catalog numbers listed are not complete.

- Select the voltage code from table on page 205 (e.g., 2196Z-FKBD).

- If power fuse will NOT be selected, select fuse clip designator from table on page 209 (e.g., 2196Z-FKBD-**24J**).

- If power fuse WILL be selected, select the fuse clip designator AND the manufacturer from table on page 209 (e.g., 2196Z-FKBD-**24JG**).

- For fuse rating, based on transformer rating, see publication 2100-TD003x-EN-P.

[3] For ratings 3kVA and larger, vented door is provided.

[4] For ratings 3kVA and larger, vented and filtered door is provided. 3kVA and larger are available on NEMA Type 12 structures but unit still will be NEMA Type 1/1G with gasket and filters. See page 114 for option -16A.

[5] Frame mounted unit. Must be located at bottom of section.

[6] 240 V and 480 V are SC-II in U.S. and PE-II in Canada. 600 V is PE-II in U.S. and SC-II in Canada.

[7] Frame mounted unit, section does not have vertical wireway next to this unit. Must be located at bottom of section.

\* The (Z) denotes that the disconnect portion of the unit is 0.5 space factor.

Control and Lighting Transformer Unit with Fusible Disconnect Switch (XFMR), continued

See 87 for product description.

**NOTE:** Do not mount transformer units below drive units. Heat from transformer units may cause drive to trip.

**NOTE:** In order to address the heating effects from loads containing a high degree of harmonic content, it may be necessary to oversize the field conductors (especially neutrals), use k-factor lighting transformers, and oversize the lighting contactor units (increase by 50%). Contact your local Rockwell Automation Sales Office.

**NOTE:** Transformers have Class 180°C insulation, 80°C rise.

**NOTE:** 3 through 50kVA consists of two (2) compartments—a fusible disconnect compartment and a transformer compartment wired and interlocked together.

For 71" high sections, see restrictions on page 24.

113

Rating kVA <sup>[1]</sup>	Fuse Clip Rating (Amperes)			Space Factor	Catalog Number <sup>[2]</sup> Wiring Type A—Class I			Delivery Program
	380 V	400 V	415 V		NEMA Type 1 and Type 1 w/ gasket <sup>[3]</sup>	NEMA Type 1 with filters and Type 1 w/ gasket and filters <sup>[4]</sup>	NEMA Type 12 <sup>[1]</sup>	
<b>SINGLE PHASE—110/115 Volt secondary with one (1) 1-pole circuit breaker <sup>[5]</sup></b>								
0.5 <sup>[5]</sup>	30	30	30	1.0	2196-AK_S-__	—	2196-AJ_S-__	PE
0.75 <sup>[5]</sup>					2196-BK_S-__	—	2196-BJ_S-__	
1 <sup>[5]</sup>					2196-CK_S-__	—	2196-CJ_S-__	
1.6 <sup>[5]</sup>				2.0	2196-ZK_S-__	—	2196-ZJ_S-__	
2 <sup>[5]</sup>					2196-EK_S-__	—	2196-EJ_S-__	
3 (1.5) <sup>[5]</sup>					2.5 <sup>[6]</sup>	2196-FK_S-__	2196-FK_S-__-16A	
<b>SINGLE PHASE—110/220 Volt secondary with two (2) 1-pole circuit breakers</b> Transformer secondary wired and protected for 220 V phase-to-phase, 110 V phase-to-center tap neutral.								
5 (2.5) <sup>[5]</sup>	30	—	—	2.5 <sup>[6]</sup>	2196-GKNP-__	2196-GKNP-__-16A	2196-GJNP-__	PE-II
7.5 (3.7) <sup>[5]</sup>	30	—	—		2196-HKNP-__	2196-HKNP-__-16A	2196-HJNP-__	
10 (5) <sup>[5]</sup>	30	—	—		2196-JKNP-__	2196-JKNP-__-16A	2196-JJNP-__	
15 (7.5) <sup>[7]</sup>	60	—	—	3.0 <sup>[8]</sup>	2196-KKNP-__	2196-KKNP-__-16A	2196-KJNP-__	
<b>SINGLE PHASE—115/230 Volt secondary with two (2) 1-pole circuit breakers</b> Transformer secondary wired and protected for 230 V phase-to-phase, 115 V phase-to-center tap neutral.								
5 (2.5)	—	30	—	2.5 <sup>[6]</sup>	2196-GKKNP-__	2196-GKKNP-__-16A	2196-GJKNP-__	PE-II
7.5 (3.7)	—	30	—		2196-HKKNP-__	2196-HKKNP-__-16A	2196-HJKNP-__	
10 (5)	—	30	—		2196-JKKNP-__	2196-JKKNP-__-16A	2196-JJKNP-__	
<b>SINGLE PHASE—120/240 Volt secondary with two (2) 1-pole circuit breakers <sup>[9]</sup></b> Transformer secondary wired and protected for 240 V phase-to-phase, 120 V phase-to-center tap neutral.								
5 (2.5) <sup>[5]</sup>	—	—	30	2.5 <sup>[6]</sup>	2196-GKIT-__	2196-GKIT-__-16A	2196-GJIT-__	PE-II
7.5 (3.7) <sup>[5]</sup>	—	—	30		2196-HKIT-__	2196-HKIT-__-16A	2196-HJIT-__	
10 (5) <sup>[5]</sup>	—	—	30		2196-JKIT-__	2196-JKIT-__-16A	2196-JJIT-__	
15 (7.5) <sup>[7]</sup>	—	—	60	3.0 <sup>[8]</sup>	2196-KKIP-__	2196-KKIP-__-16A	2196-KJIP-__	

- [1] In NEMA Type 12 applications (non-ventilated 3kVA and larger transformers), to maximize the transformer's life, it is recommended that the transformer not be loaded to greater than 50% of its nameplate rating. Number in parentheses indicates approximate derated rating. However, in many applications, NEMA Type 1 with gasket design (vented and filtered doors) may be sufficient.
- [2] The catalog numbers listed are not complete:
  - Select the voltage code from table on page 205 (e.g., 2196-FKNS).
  - Select the fuse clip designator from table on page 209 (e.g., 2196-FKNS-24J). No power fuses available.
- [3] For ratings 3kVA and larger, vented door is provided.
- [4] For ratings 3kVA and larger, vented door is provided. 3kVA and larger are available on NEMA Type 12 structures but unit still will be NEMA Type 1/1G with gasket and filters. See page 114 for option -16A.
- [5] Incorporates primary taps for future conversion to new global IEC voltage standards (e.g., 400 V/115 V/230 V). Allows conversion without the need to replace transformers.
- [6] Frame mounted unit. Must be located at bottom of section.
- [7] Tap arrangement is (2) 2-1/2% Taps FCAN, (4) 2-1/2% Taps FCBN.
- [8] Frame mounted unit, section does not have vertical wireway next to this unit. Must be located at bottom of section.
- [9] The 15kVA transformer has 110/220 V secondary with two (2) 1-pole circuit breakers.

## Transformer Units

### Bulletin 2196Z\*

#### Control and Lighting Transformer Unit with Fusible Disconnect Switch (XFMR), continued

See 87 for product description.

**NOTE:** Do not mount transformer units below drive units. Heat from transformer units may cause drive to trip.

**NOTE:** In order to address the heating effects from loads containing a high degree of harmonic content, it may be necessary to oversize the field conductors (especially neutrals), use k-factor lighting transformers, and oversize the lighting contactor units (increase by 50%). Contact your local Rockwell Automation Sales Office.

**NOTE:** Transformers have Class 180°C insulation, 80° C rise.

**NOTE:** Unit consists of two (2) compartments—a fusible disconnect compartment and a transformer compartment wired and interlocked together. The fusible disconnect compartment has a horizontal operating handle.

For 71" high sections, see restrictions on page 24.

114

8

Rating kVA <sup>[1]</sup>	Fuse Clip Rating (Amperes)			Space Factor	Catalog Number <sup>[2]</sup> Wiring Type A—Class I			Delivery Program
	380 V	400 V	415 V		NEMA Type 1 and Type 1 w/ gasket <sup>[3]</sup>	NEMA Type 1 with filters and Type 1 w/ gasket and filters <sup>[4]</sup>	NEMA Type 12 <sup>[1]</sup>	
<b>SINGLE PHASE—110/115 Volt secondary with one (1) 1-pole circuit breaker <sup>[5]</sup></b>								
3 (1.5) <sup>[5]</sup>	30	30	30	2.0 <sup>[6]</sup>	2196Z-FK_S-__	2196Z-FK_S-__-16A	2196Z-FJ_S-__	PE-II
<b>SINGLE PHASE—110/220 Volt secondary with two (2) 1-pole circuit breakers</b> Transformer secondary wired and protected for 220 V phase-to-phase, 110 V phase-to-center tap neutral.								
5 (2.5) <sup>[5]</sup>	30	—	—	2.0 <sup>[6]</sup>	2196Z-GKNP-__	2196Z-GKNP-__-16A	2196Z-GJNP-__	PE-II
7.5 (3.7) <sup>[5]</sup>	30	—	—		2196Z-HKNP-__	2196Z-HKNP-__-16A	2196Z-HJNP-__	
10 (5) <sup>[5]</sup>	30	—	—		2196Z-JKNP-__	2196Z-JKNP-__-16A	2196Z-JJNP-__	
<b>SINGLE PHASE—115/230 Volt secondary with two (2) 1-pole circuit breakers</b> Transformer secondary wired and protected for 230 V phase-to-phase, 115 V phase-to-center tap neutral.								
5 (2.5)	—	30	—	2.0 <sup>[6]</sup>	2196Z-GKKNP-__	2196Z-GKKNP-__-16A	2196Z-GJKNP-__	PE-II
7.5 (3.7)	—	30	—		2196Z-HKKNP-__	2196Z-HKKNP-__-16A	2196Z-HJKNP-__	
10 (5)	—	30	—		2196Z-JKKNP-__	2196Z-JKKNP-__-16A	2196Z-JJKNP-__	
<b>SINGLE PHASE—120/240 Volt secondary with two (2) 1-pole circuit breakers</b> Transformer secondary wired and protected for 240 V phase-to-phase, 120 V phase-to-center tap neutral.								
5 (2.5) <sup>[5]</sup>	—	—	30	2.0 <sup>[6]</sup>	2196Z-GKIT-__	2196Z-GKIT-__-16A	2196Z-GJIT-__	PE-II
7.5 (3.7) <sup>[5]</sup>	—	—	30		2196Z-HKIT-__	2196Z-HKIT-__-16A	2196Z-HJIT-__	
10 (5) <sup>[5]</sup>	—	—	30		2196Z-JKIT-__	2196Z-JKIT-__-16A	2196Z-JJIT-__	

[1] In NEMA Type 12 applications (non-ventilated 3kVA and larger transformers), to maximize the transformer's life, it is recommended that the transformer not be loaded to greater than 50% of its nameplate rating. Number in parentheses indicates approximate derated rating. However, in many applications, NEMA Type 1 with gasket design (vented and filtered doors) may be sufficient.

[2] The catalog numbers listed are not complete:

- Select the voltage code from table on page 205 (e.g., 2196Z-FKNS).
- Select the fuse clip designator from table on page 209 (e.g., 2196Z-FKNS-24J). No power fuses available.

[3] For ratings 3kVA and larger, vented door is provided.

[4] For ratings 3kVA and larger, vented door is provided. 3kVA and larger are available on NEMA Type 12 structures but unit still will be NEMA Type 1/1G with gasket and filters. See page 114 for option -16A.

[5] Incorporates primary taps for future conversion to new global IEC voltage standards (e.g., 400 V/115 V/230 V). Allows conversion without the need to replace transformers.

[6] Frame mounted unit. Must be located at bottom of section.

\* The (Z) denotes that the disconnect portion of the unit is 0.5 space factor.

See 87 for product description.

**NOTE:** Do not mount transformer units below drive units. Heat from transformer units may cause drive to trip.

**NOTE:** In order to address the heating effects from loads containing a high degree of harmonic content, it may be necessary to oversize the field conductors (especially neutrals), use k-factor lighting transformers, and oversize the lighting contactor units (increase by 50%). Contact your local Rockwell Automation Sales Office.

**NOTE:** Tap arrangement for 15-50kVA single phase transformers is (2) 2-1/2% Taps FCAN, (4) 2-1/2% Taps FCBN.

Tap arrangements for 10-45 kVA three phase transformers is (2) 2 1/ 2% Taps FCBN.

**NOTE:** Transformers have Class 180°C insulation, 80° C rise.

**NOTE:** 3 through 50kVA consists of a circuit breaker compartment and transformer compartment wired and interlocked together.

For 71" high sections, see restrictions on page 24.

115

8

Rating kVA <sup>[1]</sup>	Size of Primary Protection			Space Factor	Catalog Number <sup>[2]</sup> Wiring Type A Only—Class I			Delivery Program
	240 V	480 V	600 V		NEMA Type 1 and Type 1 w/ gasket <sup>[3]</sup>	NEMA Type 1 with filters and Type 1 w/ gasket and filters <sup>[4]</sup>	NEMA Type 12 <sup>[1]</sup>	
<b>SINGLE PHASE—120 Volt secondary with one (1) secondary fuse</b>								
0.5	15	15	15 <sup>[5]</sup>	1.0	2197-AK_D-__	—	2197-AJ_D-__	[6]
0.75					2197-BK_D-__	—	2197-BJ_D-__	
1					2197-CK_D-__	—	2197-CJ_D-__	
1.6					2197-ZK_D-__	—	2197-ZJ_D-__	
2					2197-EK_D-__	—	2197-EJ_D-__	
3 (1.5)	—	—	15	2.5 <sup>[7]</sup>	2197-FK_D-__	2197-FK_D-__-16A	2197-FJ_D-__	[8]
5 (2.5)	—	—	15	2.5 <sup>[7]</sup>	2197-GK_D-__	2197-GK_D-__-16A	2197-GJ_D-__	
<b>SINGLE PHASE—120/240 Volt secondary with two (2) secondary fuses</b>								
Transformer secondary wired and protected for 240 V phase to phase/120 V phase to center tap neutral.								
5 (2.5)	30	15	—	2.5 <sup>[7]</sup>	2197-GK_A-__	2197-GK_A-__-16A	2197-GJ_A-__	[8]
7.5 (3.7)	40	20	—		2197-HK_A-__	2197-HK_A-__-16A	2197-HJ_A-__	
10 (5)	50	30	20		2197-JK_A-__	2197-JK_A-__-16A	2197-JJ_A-__	
15 (7.5)	70	40	30	3.0 <sup>[9]</sup>	2197-KK_A-__	2197-KK_A-__-16A	2197-KJ_A-__	
25 (12.5)	125	70	60		2197-MK_A-__	2197-MK_A-__-16A	2197-MJ_A-__	
37.5 (18.5)	200	100	70	3.0	2197-XK_A-__	2197-XK_A-__-16A	2197-XJ_A-__	
50 (25)	—	150	100	20" D <sup>[9],[10]</sup>	2197-YK_A-__	2197-YK_A-__-16A	2197-YJ_A-__	
<b>THREE PHASE—120/208 Volt secondary with three (3) secondary fuses</b>								
Transformer secondary wired and protected for 208V phase to phase/120 V phase to WYE neutral.								
10 (5)	—	20	15	3.0 <sup>[9]</sup>	2197-PK_H-__	2197-PK_H-__-16A	2197-PJ_H-__	[8]
15 (7.5)	—	20	20		2197-QK_H-__	2197-QK_H-__-16A	2197-QJ_H-__	
25 (12.5)	—	40	30		2197-SK_H-__	2197-SK_H-__-16A	2197-SJ_H-__	
30 (15)	—	50	40		2197-TK_H-__	2197-TK_H-__-16A	2197-TJ_H-__	
37.5 (18.5)	—	60	50	3.0	2197-VK_H-__	2197-VK_H-__-16A	2197-VJ_H-__	
45 (22.5)	—	70	60	20" D <sup>[9]</sup>	2197-WK_H-__	2197-WK_H-__-16A	2197-WJ_H-__	

[1] In NEMA Type 12 applications (non-ventilated 3kVA and larger transformers), to maximize transformer life, it is recommended that the transformer not be loaded to greater than 50% of its nameplate rating. Number in parentheses indicates approximate derated rating. However, in many applications, NEMA Type 1 with gasket design (vented and filtered door) may be sufficient.

[2] The catalog numbers listed are not complete:  
 • Select the primary voltage code from table on page 205 (e.g., 2197-EKBD).  
 • Select the trip current from table on page 209 (e.g., 2197-EKBD-30).  
 • Select the circuit breaker from table on page 211 (e.g., 2197-EKBD-30CB).

[3] For ratings 3kVA and larger, vented door is provided.

[4] For ratings 3kVA and larger, vented and filtered door is provided. 3kVA and larger are available on NEMA Type 12 structures but unit still will be NEMA Type 1/1G with gasket and filters. See page 114 for option -16A.

[5] Transformer secondary wired and protected for 240 V phase to phase/120 V phase to center tap neutral.

[6] 240 V and 480 V are SC in U.S. and Canada. 600 V is PE in U.S. and SC in Canada.

[7] Frame mounted unit. Must be located at bottom of section.

[8] 240 V and 480 V are SC-II in U.S. and PE-II in Canada. 600 V is PE-II in U.S. and SC-II in Canada.

[9] Frame mounted unit, section does not have vertical wireway next to this unit. Must be located at bottom of section.

[10] For transformers with 240 volt primary, add 0.5 space factor.

## Transformer Units

### Bulletin 2197Z\*

#### Control and Lighting Transformer Unit with Circuit Breaker (XFMR)

See 87 for product description.

**NOTE:** Do not mount transformer units below drive units. Heat from transformer units may cause drive to trip.

**NOTE:** In order to address the heating effects from loads containing a high degree of harmonic content, it may be necessary to oversize the field conductors (especially neutrals), use k-factor lighting transformers, and oversize the lighting contactor units (increase by 50%). Contact your local Rockwell Automation Sales Office.

**NOTE:** Tap arrangement for 15-50kVA single phase transformers is (2) 2-1/2% Taps FCAN, (4) 2-1/2% Taps FCBN.

Tap arrangements for 10-45 kVA three phase transformers is (2) 2 1/ 2% Taps FCBN.

**NOTE:** Transformers have Class 180°C insulation, 80°C rise.

**NOTE:** Units consists of a circuit breaker compartment and transformer compartment wired and interlocked together. This circuit breaker compartment has a horizontal operating handle.

For 71" high sections, see restrictions on page 24.

116

8

Rating kVA <sup>[1]</sup>	Size of Primary Protection			Space Factor	Catalog Number <sup>[2]</sup> Wiring Type A Only—Class I			Delivery Program
	240 V	480 V	600 V		NEMA Type 1 and Type 1 w/ gasket <sup>[3]</sup>	NEMA Type 1 with filters and Type 1 w/ gasket and filters <sup>[4]</sup>	NEMA Type 12 <sup>[1]</sup>	
<b>SINGLE PHASE—120 Volt secondary with one (1) secondary fuse</b>								
3 (1.5)	15	15	15	2.0 <sup>[5]</sup>	2197Z-FK_D-__	2197Z-FK_D-__-16A	2197Z-FJ_D-__	[6]
5 (2.5)	—	—	15	2.0 <sup>[5]</sup>	2197Z-GK_D-__	2197Z-GK-D-__-16A	2197Z-GJ_D-__	
<b>SINGLE PHASE—120/240 Volt secondary with two (2) secondary fuses</b>								
Transformer secondary wired and protected for 240 V phase to phase/120 V phase to center tap neutral.								
5 (2.5)	30	15	—	2.0 <sup>[5]</sup>	2197Z-GK_A-__	2197Z-GK_A-__-16A	2197Z-GJ_A-__	[6]
7.5 (3.7)	40	20	20		2197Z-HK_A-__	2197Z-HK_A-__-16A	2197Z-HJ_A-__	
10 (5)	50	30	20		2197Z-JK_A-__	2197Z-JK_A-__-16A	2197Z-JJ_A-__	
15 (7.5)	70	40	30	2.5 <sup>[7]</sup>	2197Z-KK_A-__	2197Z-KK_A-__-16A	2197Z-KJ_A-__	
25 (12.5)	125	70	60		2197Z-MK_A-__	2197Z-MK_A-__-16A	2197Z-MJ_A-__	
37.5 (18.5)	200	100	70		2.5	2197Z-XK_A-__	2197Z-XK_A-__-16A	
50 (25)	—	150	100	20" D <sup>[7]</sup>	2197Z-YK_A-__	2197Z-YK_A-__-16A	2197Z-YJ_A-__	
<b>THREE PHASE—120/208 Volt secondary with three (3) secondary fuses</b>								
Transformer secondary wired and protected for 208 V phase to phase/120 V phase to WYE neutral.								
10 (5)	—	20	15	2.5 <sup>[7]</sup>	2197Z-PK_H-__	2197Z-PK_H-__-16A	2197Z-PJ_H-__	[6]
15 (7.5)	—	20	20		2197Z-QK_H-__	2197Z-QK_H-__-16A	2197Z-QJ_H-__	
25 (12.5)	—	40	30		2197Z-SK_H-__	2197Z-SK_H-__-16A	2197Z-SJ_H-__	
30 (15)	—	50	40	2.5	2197Z-TK_H-__	2197Z-TK_H-__-16A	2197Z-TJ_H-__	
37.5 (18.5)	—	60	50		2197Z-VK_H-__	2197Z-VK_H-__-16A	2197Z-VJ_H-__	
45 (22.5)	—	70	60		20" D <sup>[7]</sup>	2197Z-WK_H-__	2197Z-WK_H-__-16A	

[1] In NEMA Type 12 applications (non-ventilated 3kVA and larger transformers), to maximize transformer life, it is recommended that the transformer not be loaded to greater than 50% of its nameplate rating. Number in parentheses indicates approximate derated rating. However, in many applications, NEMA Type 1 with gasket design (vented and filtered door) may be sufficient.

[2] The catalog numbers listed are not complete:  
 • Select the primary voltage code from table on page 205 (e.g., 2197Z-FKBD).  
 • Select the trip current from table on page 209 (e.g., 2197Z-FKBD-30).  
 • Select the circuit breaker from table on page 211 (e.g., 2197Z-FKBD-30CB).

[3] For ratings 3kVA and larger, vented door is provided.

[4] For ratings 3kVA and larger, vented and filtered door is provided. 3kVA and larger are available on NEMA Type 12 structures but unit still will be NEMA Type 1/1G with gasket and filters. See page 114 for option -16A.

[5] Frame mounted unit. Must be located at bottom of section.

[6] 240 V and 480 V are SC-II in U.S. and PE-II in Canada. 600 V is PE-II in U.S. and SC-II in Canada.

[7] Frame mounted unit, section does not have vertical wireway next to this unit. Must be located at bottom of section.

\* The (Z) denotes that the disconnect portion of the unit is 0.5 space factor.

See 87 for product description.

**NOTE:** Do not mount transformer units below drive units. Heat from transformer units may cause drive to trip.

**NOTE:** In order to address the heating effects from loads containing a high degree of harmonic content, it may be necessary to oversize the field conductors (especially neutrals), use k-factor lighting transformers, and oversize the lighting contactor units (increase by 50%). Contact your local Rockwell Automation Sales Office.

**NOTE:** Transformers have Class 180°C insulation, 80°C rise.

**NOTE:** 3 through 50kVA consists of a circuit breaker compartment and transformer compartment wired and interlocked together.

For 71" high sections, see restrictions on page 24.

Rating kVA <sup>[1]</sup>	Size of Primary Protection			Space Factor	Catalog Number <sup>[2]</sup> Wiring Type A—Class I			Delivery Program
	380 V	400 V	415 V		NEMA Type 1 and Type 1 w/ gasket <sup>[3]</sup>	NEMA Type 1 with filters and Type 1 w/ gasket and filters <sup>[4]</sup>	NEMA Type 12 <sup>[1]</sup>	
<b>SINGLE PHASE—110/115 secondary with one (1) 1-pole circuit breaker <sup>[5]</sup></b>								
0.5 <sup>[5]</sup>	15	15	15	1.0	2197-AK_S-__	—	2197-AJ_S-__	PE
0.75 <sup>[5]</sup>					2197-BK_S-__	—	2197-BJ_S-__	
1 <sup>[5]</sup>					2197-CK_S-__	—	2197-CJ_S-__	
1.6 <sup>[5]</sup>					2197-ZK_S-__	—	2197-ZJ_S-__	
2 <sup>[5]</sup>					2197-EK_S-__	—	2197-EJ_S-__	
3 (1.5) <sup>[5]</sup>				2.5 <sup>[6]</sup>	2197-FK_S-__	2197-FK_S-__-16A	2197-FJ_S-__	
<b>SINGLE PHASE—110/220 Volt secondary with two (2) 1-pole circuit breakers</b> Transformer secondary wired and protected for 220 V phase-to-phase, 110 V phase-to-center tap neutral.								
5 <sup>[5]</sup> (2.5)	20	—	—	2.5 <sup>[6]</sup>	2197-GKNP-__	2197-GKNP-__-16A	2197-GJNP-__	PE-II
7.5 <sup>[5]</sup> (3.7)	20	—	—		2197-HKNP-__	2197-HKNP-__-16A	2197-HJNP-__	
10 <sup>[5]</sup> (5)	30	—	—		2197-JKNP-__	2197-JKNP-__-16A	2197-JJNP-__	
15 (7.5) <sup>[7]</sup>	50	—	—	3.0 <sup>[8]</sup>	2197-KKNP-__	2197-KKNP-__-16A	2197-KJNP-__	
<b>SINGLE PHASE—115/230 Volt secondary with two (2) 1-pole circuit breakers</b> Transformer secondary wired and protected for 230 V phase-to-phase, 115 V phase-to-center tap neutral.								
5 (2.5)	—	20	—	2.5 <sup>[6]</sup>	2197-GKKNP-__	2197-GKKNP-__-16A	2197-GJKNP-__	PE-II
7.5 (3.7)	—	20	—		2197-HKKNP-__	2197-HKKNP-__-16A	2197-HJKNP-__	
10 (5)	—	30	—		2197-JKKNP-__	2197-JKKNP-__-16A	2197-JJKNP-__	
<b>SINGLE PHASE—120/240 Volt secondary with two (2) 1-pole circuit breakers <sup>[9]</sup></b> Transformer secondary wired and protected for 240 V phase-to-phase, 120 V phase-to-center tap neutral.								
5 (2.5) <sup>[5]</sup>	—	—	20	2.5 <sup>[6]</sup>	2197-GKIT-__	2197-GKIT-__-16A	2197-GJIT-__	PE-II
7.5 (3.7) <sup>[5]</sup>	—	—	20		2197-HKIT-__	2197-HKIT-__-16A	2197-HJIT-__	
10 (5) <sup>[5]</sup>	—	—	30		2197-JKIT-__	2197-JKIT-__-16A	2197-JJIT-__	
15 (7.5) <sup>[7]</sup>	—	—	50	3.0 <sup>[8]</sup>	2197-KKIP-__	2197-KKIP-__-16A	2197-KJIP-__	

[1] In NEMA Type 12 applications (non-ventilated 3kVA and larger transformers), to maximize the transformer's life, it is recommended that the transformer not be loaded to greater than 50% of its nameplate rating. Number in parentheses indicates approximate derated rating. However, in many applications, NEMA Type 1 with gasket design (vented and filtered doors) may be sufficient.

[2] The catalog numbers listed are not complete.  
 • Select the primary voltage code from table on page 205 (e.g., 2197-EKNS).  
 • Select the trip current from table on page 209 (e.g., 2197-EKNS-30).  
 • Select the circuit breaker from table on page 211 (e.g., 2197-EKNS-30CB).

[3] For ratings 3kVA and larger, vented door is provided.  
 [4] For ratings 3kVA and larger, vented and filtered door is provided. 3kVA and larger are available on NEMA Type 12 structures but unit still will be NEMA Type 1/1G with gasket and filters. See page 114 for option -16A.

[5] Incorporates primary taps for future conversion to new global IEC voltage standards (e.g., 400 V/115 V/230 V). Allows conversion without the need to replace transformers.

[6] Frame mounted unit. Must be located at bottom of section.

[7] Tap arrangement is two 2-1/2% Taps FCAN, four 2-1/2% Taps FCBN.

[8] Frame mounted unit, section does not have vertical wireway next to this unit. Must be located at bottom of section.

[9] The 15kVA transformer has 110/220 V secondary with two (2) 1-pole circuit breakers.

## Transformer Units

### Bulletin 2197Z\*

#### Control and Lighting Transformer Unit with Circuit Breaker (XFMR), continued

See 87 for product description.

**NOTE:** Do not mount transformer units below drive units. Heat from transformer units may cause drive to trip.

**NOTE:** In order to address the heating effects from loads containing a high degree of harmonic content, it may be necessary to oversize the field conductors (especially neutrals), use k-factor lighting transformers, and oversize the lighting contactor units (increase by 50%). Contact your local Rockwell Automation Sales Office.

**NOTE:** Transformers have Class 180°C insulation, 80° C rise.

**NOTE:** Units consists of a circuit breaker compartment and transformer compartment wired and interlocked together. The circuit breaker compartment has a horizontal operation handle.

For 71" high sections, see restrictions on page 24.

118

Rating kVA <sup>[1]</sup>	Size of Primary Protection			Space Factor	Catalog Number <sup>[2]</sup> Wiring Type A—Class I			Delivery Program
	380 V	400 V	415 V		NEMA Type 1 and Type 1 w/ gasket <sup>[3]</sup>	NEMA Type 1 with filters and Type 1 w/ gasket and filters <sup>[4]</sup>	NEMA Type 12 <sup>[1]</sup>	
<b>SINGLE PHASE—110/115 secondary with one (1) 1-pole circuit breaker <sup>[5]</sup></b>								
3 (1.5) <sup>[5]</sup>	15	15	15	2.0 <sup>[6]</sup>	2197Z-FK_S-__	2197Z-FK_S-__-16A	2197Z-FJ_S-__	PE-II
<b>SINGLE PHASE—110/220 Volt secondary with two (2) 1-pole circuit breakers</b> Transformer secondary wired and protected for 220 V phase-to-phase, 110 V phase-to-enter tap neutral.								
5 <sup>[5]</sup> (2.5)	20	—	—	2.0 <sup>[6]</sup>	2197Z-GKNP-__	2197Z-GKNP-__-16A	2197Z-GJNP-__	PE-II
7.5 <sup>[5]</sup> (3.7)	20	—	—		2197Z-HKNP-__	2197Z-HKNP-__-16A	2197Z-HJNP-__	
10 <sup>[5]</sup> (5)	30	—	—		2197Z-JKNP-__	2197Z-JKNP-__-16A	2197Z-JJNP-__	
15 (7.5) <sup>[7]</sup>	50	—	—	2.5 <sup>[8]</sup>	2197Z-KKNP-__	2197Z-KKNP-__-16A	2197Z-KJNP-__	
<b>SINGLE PHASE—115/230 Volt secondary with two (2) 1-pole circuit breakers</b> Transformer secondary wired and protected for 230 V phase-to-phase, 115 V phase-to-center tap neutral.								
5 (2.5)	—	20	—	2.0 <sup>[6]</sup>	2197Z-GKKNP-__	2197Z-GKKNP-__-16A	2197Z-GJKNP-__	PE-II
7.5 (3.7)	—	20	—		2197Z-HKKNP-__	2197Z-HKKNP-__-16A	2197Z-HJKNP-__	
10 (5)	—	30	—		2197Z-JAKNP-__	2197Z-JAKNP-__-16A	2197Z-JJKNP-__	
<b>SINGLE PHASE—120/240 Volt secondary with two (2) 1-pole circuit breakers <sup>[9]</sup></b> Transformer secondary wired and protected for 240 V phase-to-phase, 120 V phase-to-center tap neutral.								
5 (2.5) <sup>[5]</sup>	—	—	20	2.0 <sup>[6]</sup>	2197Z-GKIT-__	2197Z-GKIT-__-16A	2197Z-GJIT-__	PE-II
7.5 (3.7) <sup>[5]</sup>	—	—	20		2197Z-HKIT-__	2197Z-HKIT-__-16A	2197Z-HJIT-__	
10 (5) <sup>[5]</sup>	—	—	30		2197Z-JKIT-__	2197Z-JKIT-__-16A	2197Z-JJIT-__	
15 (7.5) <sup>[7]</sup>	—	—	50	2.5 <sup>[8]</sup>	2197Z-KKIP-__	2197Z-KKIP-__-16A	2197Z-KJIP-__	

[1] In NEMA Type 12 applications (non-ventilated 3kVA and larger transformers), to maximize the transformer's life, it is recommended that the transformer not be loaded to greater than 50% of its nameplate rating. Number in parentheses indicates approximate derated rating. However, in many applications, NEMA Type 1 with gasket design (vented and filtered doors) may be sufficient.

[2] The catalog numbers listed are not complete.

- Select the primary voltage code from table on page 205 (e.g., 2197Z-EKNS).

- Select the trip current from table on page 209 (e.g., 2197Z-EKNS-30).

- Select the circuit breaker from table on page 211 (e.g., 2197Z-EKNS-30CB).

[3] For ratings 3kVA and larger, vented door is provided.

[4] For ratings 3kVA and larger, vented and filtered door is provided. 3kVA and larger are available on NEMA Type 12 structures but unit still will be NEMA Type 1/1G with gasket and filters. See page 114 for option -16A.

[5] Incorporates primary taps for future conversion to new global IEC voltage standards (e.g., 400 V/115 V/230 V). Allows conversion without the need to replace transformers.

[6] Frame mounted unit. Must be located at bottom of section.

[7] Tap arrangement is two 2-1/2% Taps FCAN, four 2-1/2% Taps FCBN.

[8] Frame mounted unit, section does not have vertical wireway next to this unit. Must be located at bottom of section.

[9] The 15kVA transformer has 110/220 V secondary with two (2) 1-pole circuit breakers.

\* The (Z) denotes that the disconnect portion of the unit is 0.5 space factor.

# Miscellaneous Units

## Catalog Number Explanation - Full Section Mounting Plates

*Full Section Blank Mounting Plate with No Disconnecting Means, with or without Horizontal Power Bus*

**2100 - E K C 1 X 1 B - - 120 - \*\***

*Full Section Blank Mounting Plate with Fusible Disconnect Switch, with or without Horizontal Power Bus*

**2100 - F K C 1 X 1 B - 24J - 120 - \*\***

*Full Section Blank Mounting Plate with Circuit Breaker, with or without Horizontal Power Bus*

**2100 - G K C 1 X 1 B - 32CB - 120 - \*\***

Bulletin Number	Disconnecting Means	NEMA Type	Voltage	Unit Depth	Placeholder	Unit Width	Mounting Plate Depth	Fuse Clip or Circuit Breaker	Horizontal Power Bus	Options
-----------------	---------------------	-----------	---------	------------	-------------	------------	----------------------	------------------------------	----------------------	---------

119A

Code	Type
2100	

119F

Code	Placeholder
X	X is a placeholder

119B

Code	Disconnecting Means
E	No disconnecting means
F	With fusible disconnect
G	With circuit breaker

119D

Code	Voltage
A	Up to 250V
C	Up to 600V

119G

Code	Unit Width
1	20" wide
2	25" wide
3	30" wide
4	35" wide
5	40" wide

119K

Code	Option
	See available Options on page 23.

119E

Code	Unit Depth
1	15" Deep
2	20" Deep

119H

Code	Mounting Plate Depth
B	14" Deep
C	19" Deep
D	8.5" Deep

119J

Code	Horizontal Power Bus
Blank	Provided with horizontal power bus
120	No horizontal power bus is provided

119C

Code	NEMA Enclosure Type
K	NEMA Type 1 or Type 1 with gasket
J	NEMA Type 12

119I

Code	Fuse Clip or Circuit Breaker
2100F and 2100G only	See page 100 for fuse clip rating or circuit breaker

## Miscellaneous Units

### Full Section Blank Mounting Plates

- Line side of disconnect or circuit breaker is connected to horizontal bus for sections with horizontal bus.
- Customer cables connect to the line side of the disconnect or circuit breaker for sections without horizontal bus.

120

Description				Space Factor	Catalog Number <sup>[1]</sup>		Delivery Program
					NEMA Type 1 and Type 1 w/ gasket	NEMA Type 12	
Full section Blank Mounting Plates <sup>[2]</sup>	Full width door, no vertical wireway or vertical bus, with or without horizontal power bus. Frame Mounted.	With no disconnect means	With horizontal bus	6.0	2100-EKC_X __	2100-EJC_X __	SC-II
			Without horizontal bus		2100-EKC_X __-120	2100-EJC_X __-120	
		With fusible disconnect switch	With horizontal bus		2100-FK_X __-__	2100-FJ_X __-__	
			Without horizontal bus		2100-FK_X __-__-120	2100-FJ_X __-__-120	
		With circuit breaker	With horizontal bus		2100-GKC_X __-__	2100-GJC_X __-__	
			Without horizontal bus		2100-GKC_X __-__-120	2100-GJC_X __-__-120	

[1] The catalog numbers listed are not complete:

#### For 2100-E catalog numbers

- Select unit depth from table below (e.g., 2100-EKC1).
- Select unit width from table below (e.g., 2100-EKC1X1).
- Select mounting plate depth from table below (e.g., 2100-EKC1X1D).

#### For 2100-F catalog numbers

- Select fuse clip voltage from table below (e.g., 2100-FKC).
- Select unit depth from table below (e.g., 2100-FKC1).
- Select unit width from table below (e.g., 2100-FKC1X1).
- Select mounting plate depth from table below (e.g., 2100-FXC1X1D).
- Select disconnect rating and fuse clip from table on page 100 (e.g., 2100-FKC1X1D-24J).

#### For 2100-G catalog numbers

- Select unit depth from table below (e.g., 2100-GKC1).
- Select unit width from table below (e.g., 2100-GKC1X1).
- Select mounting plate depth from table below (e.g., 2100-GKC1X1D).
- Select trip current and circuit breaker option from tables on page 100 (e.g., 2100-GKC1X1D-32CB).

[2] 20" wide sections can be grouped up to 3 sections in a shipping block. 25" and wider sections are in separate shipping blocks. Sections without horizontal bus must be located on the end of the MCC lineup, in a separate shipping block.

#### Voltage Code

121

Fuse Clip Voltage	Code
250	A
600	C

#### Unit Depth

122

Unit Depth (Inches)	Code
15	1
20	2

#### Unit Width

123

Width (Inches)	Code	Depth
20	1	15
25	2	
30	3	
35	4	
40 <sup>[1]</sup>	5	
20	1	20
25	2	
30	3	
35	4	
40 <sup>[1]</sup>	5	

[1] Only available with 2100-E. 40" wide section is a two-door section with a 3-point latch. 40" wide cannot have horizontal power bus.

#### Mounting Plate Depth

124

Mounting Plate Depth (Inches)	Code
14	B <sup>[1],[2]</sup>
19	C <sup>[3]</sup>
8.5	D <sup>[4]</sup>

[1] Horizontal bus is 5" deeper than standard.

[2] For 15" deep sections without horizontal bus or 20" deep sections with or without horizontal bus.

[3] Only available with 20" deep section without horizontal bus.

[4] Not available with 40" wide mounting plate.

**Disconnect Rating and Fuse Clip**

125

Disconnect Rating and Fuse Clip Size	Fuse Clip Class	Short Circuit withstand Rating through 600V	Fuse Clip Designator
30	J	100kA	24J
	R	100kA	24R
	H	10kA	24
60	J	100kA	25J
	R	100kA	25R
	H	10kA	25
100	J	100kA	26J
	R	100kA	26R
	H	10kA	26
200	J	100kA	27J
	R	100kA	27R
	H	10kA	27
400	J	100kA	28J
	R	100kA	28R
	H	10kA	28

**Trip Current**

126

Trip Current (Amperes)	Number	Trip Current (Amperes)	Number	Trip Current (Amperes)	Number
15	30	80	38	200	44
20	31	90	39	225	45
30	32	100	40	250	46
40	34	125	41	300	48
50	35	150	42	350	49
60	36	175	43	400	50
70	37				

**Circuit Breaker Option \***

127

Rating (Amperes)	Standard Interrupting Capacity		Medium Interrupting Capacity w/ Current Limiter		Medium Interrupting Capacity		High Interrupting Capacity	
	Suffix	Frame	Suffix	Frame	Suffix	Frame	Suffix	Frame
15-50	—	—	CD	I3C-CL	CB	I3C	CM	I6C
60-100	—	—	CD	I3C-CL	CB	I3C	CM	I6C
125-150	—	—	CD	I3C-CL	CB	I3C	CM	I6C
175-225	CT	JD3D	—	—	—	—	CM	JD6D
250-400	CT	K3D	—	—	—	—	CM	K6D

\* Refer to page 234 for circuit breaker interrupting capacity ratings.

## Miscellaneous Units

### Blank Unit Doors

128

Description	Space Factor	Catalog Number Wiring Type A Only—Class I		Delivery Program	
		NEMA Type 1 and Type 1 w/ gasket	NEMA Type 12		
		Blank Unit Door	Covers the unused unit space (includes unit support pan)		0.5
1.0	2100-BK10	2100-BJ10			
1.5	2100-BK15	2100-BJ15			
2.0	2100-BK20	2100-BJ20			
2.5	2100-BK25	2100-BJ25			
3.0	2100-BK30	2100-BJ30			
3.5	2100-BK35	2100-BJ35			
4.0	2100-BK40	2100-BJ40			

### Field-Mounted Equipment Units

129

Description	Space Factor	Catalog Number Wiring Type A Only—Class I		Delivery Program
		NEMA Type 1 and Type 1 w/ gasket	NEMA Type 12	
		Empty Unit Insert <sup>[1]</sup>	0.5 <sup>[2]</sup>	
1.0	2100-NK10		2100-NJ10	
1.5	2100-NK15		2100-NJ15	
2.0	2100-NK20		2100-NJ20	
2.5	2100-NK25		2100-NJ25	
3.0	2100-NK30		2100-NJ30	
3.5	2100-NK35		2100-NJ35	
4.0	2100-NK40		2100-NJ40	
Empty Unit Insert with Disconnecting Means <sup>[1],[3],[4]</sup>	1.5	2100D-CK_ _ _	2100D-CJ_ _ _	
	2.0	2100D-DK_ _ _	2100D-DJ_ _ _	
	2.5	2100D-EK_ _ _	2100D-EJ_ _ _	
	3.0	2100D-FK_ _ _	2100D-FJ_ _ _	
	3.5	2100D-GK_ _ _	2100D-GJ_ _ _	
	4.0	2100D-HK_ _ _	2100D-HJ_ _ _	
	1.5	2100M-CKC_ _ _	2100M-CJC_ _ _	
	2.0	2100M-DKC_ _ _	2100M-DJC_ _ _	
	2.5	2100M-EKC_ _ _	2100M-EJC_ _ _	
	3.0	2100M-FKC_ _ _	2100M-FJC_ _ _	
	3.5	2100M-GKC_ _ _	2100M-GJC_ _ _	
	4.0	2100M-HKC_ _ _	2100M-HJC_ _ _	

- [1] See Options, Modifications, and Accessories, pages 123, for terminal block options.  
 [2] Terminal block options (-800, -801, -802, -803, -804) are not available on 2100-NK05 or 2100-NJ05.  
 [3] These units do not meet service entrance requirements. Not intended to be used as feeder circuits.  
 [4] See Appendix for interrupting capacity ratings.  
 [5] The catalog numbers listed are not complete:  
 • Select the voltage code from table on page 103 (e.g., 2100D-CKC).  
 • Select the fuse clip designator from table on page 103 (e.g., 2100D-CKC-24J).  
 • If power fuse will be selected, select from page 208 (e.g., 2100D-CKC-24J-604G).  
 [6] The catalog numbers listed are not complete:  
 • Select the trip current from table on page 103 (e.g., 2100M-CKC-30).  
 • Select the circuit breaker from table on page 103 (e.g., 2100M-CKC-30CB).

**Tables for Configuring Bulletin 2100D and 2100M Unit Catalog Numbers**

**Voltage Code** 130

Fuse Clip Voltage	Voltage Code
250	A
600	C

**Fuse Clip Designator \*** 131

Fuse Clip Rating (Amperes)	Fuse Clip Class	Short Circuit withstand Rating through 600V	Fuse Clip Designator
30	J	100kA	24J
	R	100kA	24R
	H	10kA	24
	CC	100kA	24C
60	J	100kA	25J
	R	100kA	25R
	H	10kA	25
100	J	100kA	26J
	R	100kA	26R
	H	10kA	26
200 <sup>[1]</sup>	J	100kA	27J
	R	100kA	27R
	H	10kA	27

[1] Not available in 1.5 space factors.

**Trip Current** 132

Trip Current (Amperes)	Number	Trip Current (Amperes)	Number
15	30	90	39
20	31	100	40
30	32	125	41
40	34	150	42
50	35	175	43
60	36	200	44
70	37	225	45
80	38	—	—

**Inverse Time (Thermal Magnetic) Circuit Breaker Option <sup>†,‡</sup>** 133

Rating (Amperes)	Standard Interrupting Capacity		Medium Interrupting Capacity w/ Current Limiter		Medium Interrupting Capacity		High Interrupting Capacity	
	Suffix	Frame	Suffix	Frame	Suffix	Frame	Suffix	Frame
15-50	—	—	CD	I3C-CL	CB	I3C	CM	I6C
60-100	—	—	CD	I3C-CL	CB	I3C	CM	I6C
125-150	—	—	CD	I3C-CL	CB	I3C	CM	I6C
175-225	CT	JD3D	—	—	—	—	CM	JD6D

\* Refer to publication 2100-TD003x-EN-P, *CENTERLINE Motor Control Centers Power Fuses*.

† Refer to page 234 for circuit breaker interrupting capacity ratings.

‡ Refer to publication 2100-TD002x-EN-P, *CENTERLINE MCCs Thermal Magnetic Circuit Breakers*.

Miscellaneous DeviceNet Units

Description	Space Factor	Catalog Number Wiring Type A Only—Class I		Delivery Program
		NEMA Type 1 and Type 1 w/ gasket	NEMA Type 12	
DeviceNet Power Supply Unit (110-120VAC input and 8.0A 24VDC output) <sup>[1]</sup> This power supply is to be used with 8.0A Class I Cable only. Refer to DNET-UM072x-EN-P, <i>DeviceNet Cable System Planning and Installation Manual</i> . <sup>[2]</sup>	0.5	2100-DPS8KXWD	2100-DPS8JXWD	SC
	1.0	2100-DPS8K <sub>[3]</sub>	2100-DPS8J <sub>[3]</sub>	
	1.0 <sup>[4]</sup>	2100-DPS8K <sub>-30</sub> <sup>[6]</sup>	2100-DPS8J <sub>-30</sub> <sup>[6]</sup>	
Redundant DeviceNet Power Supply Unit (110-120VAC input and 8.0A, 24VDC output). Two power supplies providing back-up for DeviceNet system. <sup>[1], [5]</sup>	1.0	2100-DPS8KXWD-767C	2100-DPS8JXWD-767C	
	1.5	2100-DPS8K <sub>-767C</sub> <sup>[3]</sup>	2100-DPS8J <sub>-767C</sub> <sup>[3]</sup>	
	1.5	2100-DPS8K <sub>-30</sub> <sub>-767C</sub> <sup>[6]</sup>	2100-DPS8J <sub>-30</sub> <sub>-767C</sub> <sup>[6]</sup>	
Bulletin 1788 ControlNet to DeviceNet linking device used to interface a DeviceNet network to a ControlNet network without the need for a PLC chassis. <sup>[7], [8]</sup>	0.5	2100-C2DKXWD	2100-C2DJXWD	
	1.0	2100-C2DK <sub>[3]</sub>	2100-C2DJ <sub>[3]</sub>	
	1.0	2100-C2DK <sub>-30</sub> <sup>[6]</sup>	2100-C2DJ <sub>-30</sub> <sup>[6]</sup>	
Bulletin 1788 Ethernet to DeviceNet linking device. Used to connect an Ethernet network to a DeviceNet network without the need for a PLC chassis. <sup>[7], [9]</sup>	0.5	2100-E2DKXWD	2100-E2DJXWD	
	1.0	2100-E2DK <sub>[3]</sub>	2100-E2DJ <sub>[3]</sub>	
	1.0	2100-E2DK <sub>-30</sub> <sup>[6]</sup>	2100-E2DJ <sub>-30</sub> <sup>[6]</sup>	
External DeviceNet Connector Unit with remotely powered 120VAC receptacle	0.5	2100-DCK05XWD	2100-DCJ05XWD	

- [1] Includes buffer module which provides for minimum 500ms ride-through at full-load. Power supply must be located within one section of center for MCCs with eight or more sections.
- [2] See page 123 for optional external DeviceNet connector with 120VAC receptacle (option 767A). DeviceNet power supply requires a 95-132VAC 50/60 Hz power source that provides sinusoidal waveform. Use of non-sinusoidal power sources, including some UPSs, could damage the DeviceNet power supply.
- [3] The catalog numbers listed are not complete. Short circuit withstand rating is 100kA. Select the voltage code from the Voltage Code Table below (e.g., 2100-DPS8K**B**).
- [4] Requires 1.5 space factor when circuit breaker suffix CD is specified.
- [5] Optional DeviceNet Starter Auxiliary (Option -11DSA3) is available. Select from page 114.
- [6] The catalog numbers listed are not complete:
  - Select the voltage code from the Voltage Code Table below (e.g., 2100-DPS8K**B**).
  - Select the circuit breaker from the Inverse Time (Thermal Magnetic) Circuit Breaker Option Table below (e.g., 2100-DPS8K**B**-30**CB**).
- [7] ControlNet to DeviceNet linking device units are supplied with a 1794 Flex I/O power supply to provide the 24VDC source for the unit so the linking device unit does not burden the DeviceNet power supply with its 1.0A load.
- [8] Refer to publication CNET-IN002x-EN-P, ControlNet Coax Media Planning and Installation Guide, and 1770-IN041x-EN-P, Industrial Automation Wiring and Grounding Guidelines, for information on installing and routing ControlNet Cable.
- [9] Refer to publication ENET-IN001x-EN-P, Ethernet Planning Guide, and 1770-IN041x-EN-P, Industrial Automation Wiring and Grounding Guidelines, for information on installing and routing ethernet cable.

Voltage Code 135

Fuse Clip Voltage	Voltage Code
220-230	P
240	A
380	N
400	KN
415	I
480	B
600	C

Inverse Time (Thermal Magnetic) Circuit Breaker Option<sup>[1]</sup> 136

Suffix	Frame Type	Circuit Breaker Description
CD	I3C-CL	Medium Interrupting Capacity with Current Limiter
CB	I3C	Medium Interrupting Capacity
CM	I6C	High Interrupting Capacity

[1] Refer to Appendix for circuit breaker interrupting capacity ratings.

Other Miscellaneous Units

Description	Space Factor	Catalog Number Wiring Type A Only—Class I		Delivery Program		
		NEMA Type 1 and Type 1 w/ gasket	NEMA Type 12			
NEMA Type "C" Terminal Board Unit (supplied unwired)	1.0	Top- mounted	44 TB	2100-CK10T-0044CA	2100-CJ10T-0044CA	SC
			66 TB	2100-CK10T-0066CA	2100-CJ10T-0066CA	
			88 TB	2100-CK10T-0088CA	2100-CJ10T-0088CA	
			110 TB	2100-CK10T-0110CA	2100-CJ10T-0110CA	
		Bottom- mounted	44 TB	2100-CK10B-0044CA	2100-CJ10B-0044CA	
			66 TB	2100-CK10B-0066CA	2100-CJ10B-0066CA	
			88 TB	2100-CK10B-0088CA	2100-CJ10B-0088CA	
			110 TB	2100-CK10B-0110CA	2100-CJ10B-0110CA	
	1.5	Top- mounted	76 TB	2100-CK15T-0076CA	2100-CJ15T-0076CA	
			114 TB	2100-CK15T-0114CA	2100-CJ15T-0114CA	
			152 TB	2100-CK15T-0152CA	2100-CJ15T-0152CA	
			190 TB	2100-CK15T-0190CA	2100-CJ15T-0190CA	
		Bottom- mounted	76 TB	2100-CK15B-0076CA	2100-CJ15B-0076CA	
			114 TB	2100-CK15B-0114CA	2100-CJ15B-0114CA	
			152 TB	2100-CK15B-0152CA	2100-CJ15B-0152CA	
			190 TB	2100-CK15B-0190CA	2100-CJ15B-0190CA	
Smoke Detector Unit (not available with T-handle latches)	0.5	2100-SD1	2100-SD1	PE		
Neutral Connection Plate Unit <sup>[1]</sup>	0.5	2100-BKNPC-05SF	2100-BJNPC-05SF	SC		
	0.5	2100-BKNPS-05SF	2100-BJNPS-05SF	PE		
Surge Protective Device Unit (formerly known as TVSS) The SPD consists of an IslaGuard surge suppression system by Control Concepts, with circuitry provided to monitor the status of all protection modes. Unit consists of a fused disconnect feeding a surge protective device (SPD) rated to provide a minimum of 160kA per phase of surge current protection. The unit is provided with one green light as a status indicator. (Response time is 0.5nS) SPD meets UL 1449 requirements. Refer to publication 2100-TD023x-EN-P, <i>Surge Protective Device Unit</i> for more information.	0.5	WYE power systems with a solidly grounded neutral 3-wire	480V L-L, 277V L-G <sup>[2]</sup>	2100-SPKB-1	2100-SPJB-1	PE
			600V L-L, 346V L-G <sup>[3]</sup>	2100-SPKC-1	2100-SPJC-1	
			208V L-L, 120V L-G <sup>[3]</sup>	2100-SPKH-1	2100-SPJH-1	
			380V L-L, 220V L-G <sup>[3]</sup>	2100-SPKN-1	2100-SPJN-1	
			400V L-L, 230V L-G <sup>[3]</sup>	2100-SPKN-1	2100-SPJKN-1	
			415V L-L, 240V L-G <sup>[3]</sup>	2100-SPKI-1	2100-SPJI-1	
	WYE power systems with a solidly grounded neutral, 4-wire	480V L-L, 277V L-G, 277V L-N	2100-SPKB-3	2100-SPJB-3	SC	
		WYE power systems with impedance grounded neutral or 3 Phase, 3 Wire Delta Power Systems	480V	2100-SPKB-2		2100-SPJB-2
	600V		2100-SPKC-2	2100-SPJC-2		
	240V		2100-SPKA-2	2100-SPJA-2		
380V	2100-SPKN-2		2100-SPJN-2			
400V	2100-SPKN-2		2100-SPJKN-2			
415V	2100-SPKI-2	2100-SPJI-2				
Corner Section	6.0	2100-CS60	2100-CS60	SC-II		

9

[1] Neutral Connection Plate 0.5 SF Unit can only be used in sections with vertical wireway. **Not for use** in sections with full width frame mounted units, including all mains. When horizontal neutral bus is selected the cable connection from the neutral connection plate to the horizontal neutral plate is NOT provided.

[2] For systems with neutral bus (4-wire systems), use 2100-SP\_B-3

[3] For systems with neutral bus (4-wire systems), contact your local Rockwell Automation Sales Office.



# Factory-Installed Options, Modifications, Accessories for Contactors and Starters, Metering, Mains and Feeders, Lighting and Power Panels, Transformer and Miscellaneous Units

Multiple option numbers are separated by a dash and added to the base catalog number in ascending order.

138

Option	Description	FVC	FVR	FVNR	TS1W TS2W	TSR1W TSR2W	TSR1W TSR2W	Option Number	Delivery Program
		2102L 2103L	2106 2107	2112 2113	2122 2123	2126E 2127E 2126F 2127F	2126J 2127J 2126K 2127K		
Push Buttons [1],[2],[3]	START - STOP <sup>[4]</sup>			✓				-1	SC
	FORWARD - REVERSE - STOP		✓						
	HIGH - LOW - STOP				✓				
	OFF	✓						-1B	
	STOP		✓	✓	✓	✓	✓		
	ON - OFF <sup>[4]</sup>	✓						-1E	
FAST - SLOW - STOP				✓					
Push Buttons and Selector Switch [1],[2]	HAND-ON, HAND-OFF, HAND-OFF-AUTO	✓						-1F <sup>[5]</sup>	
	HAND-START, HAND-STOP, HAND-OFF-AUTO			✓					
Control Station Housing <sup>[6]</sup>	Blank	✓	✓	✓	✓	✓	✓	-2	
	1 hole—for one pilot device	✓	✓	✓	✓	✓	✓	-2A	
	2 holes—for two pilot devices	✓	✓	✓	✓	✓	✓	-2B	
	3 holes—for three pilot devices	✓	✓	✓	✓	✓	✓	-2C	
	4 holes—for four pilot devices	✓		✓				-2D <sup>[7]</sup>	
Selector Switch [1],[2] (800H) (maximum one switch per unit)	HAND - OFF - AUTO	✓		✓				-3	
	FORWARD - OFF - REVERSE		✓ <sup>[3]</sup>						
	HIGH - OFF - LOW				✓ <sup>[3]</sup>				
	FORWARD - OFF - REVERSE <b>and</b> HIGH - LOW					✓			
	HIGH - LOW - OFF - REVERSE						✓		
	FAST - OFF - SLOW				✓			-3E <sup>[3]</sup>	
	OFF - ON	✓		✓					
	FORWARD - OFF - REVERSE <b>and</b> FAST - SLOW					✓			
FAST - SLOW - OFF - REVERSE						✓			

10

- [1] Push buttons may not be used in conjunction with selector switches, except with option 1F. Generally, when more than three devices are selected, Bulletin 800F pilot devices are supplied. When three or less devices are selected, Bulletin 800T pilot devices are supplied except selector switches are Bulletin 800H devices. On 0.5 space factor units, Bulletin 800F pilot devices are supplied.
- [2] Maximum of four (4) pilot devices on 0.5 space factor units and maximum of three (3) pilot devices on dual mounted units. Legend plates are available in French or Spanish at no additional cost by adding **860F** or **860S** to catalog string number.
- [3] Mutually exclusive with DeviceNet communication modules, DeviceNet starter auxiliary (11DSA2, 11DSA3) and E3 solid-state overloads (7FEC\_ \_) and E1 Plus solid state overload relay with DeviceNet communication module (7FEE\_D).
- [4] Two (2) Bulletin 800F pilot lights will be supplied when two (2) pilot lights are selected in conjunction with push buttons, separate or transformer control only. Only one (1) 800T pilot light can be supplied on 2103L or 2113 dual units when push buttons are also selected.
- [5] When option 1F is used with 11DSA\_ , 7FEE\_D, or 7FEC\_ , option 90 (1 N.O. auxiliary contact) is required (NOTE: required option code for Bulletin 2112 and 2113 vacuum contactor starter units is 900111).
- [6] Available only on units without pilot devices. The control station on the dual 2103L or dual 2113 is a flat mounting plate, flush mounted to the door of the unit. Holes are for Bulletin 800T devices when unit is 1.0 space factor and larger. Holes are for Bulletin 800F pilot devices when unit is 0.5 space factor.
- [7] Not available for 1.0 space factor and larger units.

## Factory-Installed Options, Modifications, Accessories for Contactors and Starters, Metering, Mains and Feeders, Lighting and Power Panels, Transformer and Miscellaneous Units

Multiple option numbers are separated by a dash and added to the base catalog number in ascending order.

### Pilot Lights (Non-Push-To-Test)

- Bulletin 800T pilot lights are transformer type, Bulletin 800F pilot lights are full-voltage type.
- When three or less devices are selected, pilot devices supplied are Bulletin 800T (800H for selector switches).
- When more than three devices are selected, pilot devices supplied are Bulletin 800F.
- On 0.5 space factor units, pilot devices supplied are Bulletin 800F, maximum of four (4) pilot devices may be selected.
- On dual mounted units, pilot devices supplied are Bulletin 800T (800H for selector switches), maximum of three (3) pilot devices may be selected.
- When selected, option 85T (Elapsed Time Meter) occupies the space of one Bulletin 800T (or 800H) pilot device or the space of two Bulletin 800F pilot devices, reducing the number of other devices which may be selected.
- Legend plates are available in French or Spanish at no additional cost by adding 860F or 860S to catalog string number.

139

Description	FVC	FVR	FVNR	TS1W TS2W	TSR1W TSR2W	TSR1W TSR2W	Incandescent Lamps <sup>[1]</sup>	L.E.D. Lamps <sup>[2]</sup>	Delivery Program
	2102L 2103L	2106 2107	2112 2113	2122 2123	2126E 2127E 2126F 2127F	2126J 2127J 2126K 2127K	Option Number <sup>[2]</sup>	Option Number <sup>[2]</sup>	
ON <sup>[3]</sup>	✓						-4_	-4L_	SC <sup>[4]</sup>
ON -OFF <sup>[5], [6]</sup>	✓						-4_	-4L_	
FORWARD - REVERSE <sup>[7]</sup>		✓					-4_	-4L_	
FORWARD - REVERSE - OFF <sup>[8]</sup>		✓					-4_	-4L_	
ON <sup>[9]</sup>			✓				-4_	-4L_	
ON -OFF <sup>[6], [10]</sup>			✓				-4_	-4L_	
HIGH - LOW <sup>[11]</sup>				✓			-4_	-4L_	
FAST - SLOW <sup>[11]</sup>				✓			-4E_	-4EL_	
HIGH - LOW - OFF <sup>[12]</sup>				✓			-4_	-4L_	
FAST - SLOW - OFF <sup>[12]</sup>				✓			-4E_	-4EL_	
HIGH - LOW - FORWARD - REVERSE					✓	✓	-4_	--	
FAST - SLOW - FORWARD - REVERSE					✓	✓	-4E_	--	
HIGH - LOW - FORWARD - REVERSE - OFF <sup>[13]</sup>					✓	✓	-4_	--	
FAST - SLOW - FORWARD - REVERSE - OFF <sup>[13]</sup>					✓	✓	-4E_	--	
OVERLOAD <sup>[14]</sup>		✓	✓ <sup>[6]</sup>	✓	✓	✓	-4T_	-4TL_	

[1] Bulletin 800F incandescent lamps are only available for 110-120VAC separate or transformer control.

[2] Option numbers are not complete, select pilot light lens color, add letter(s) to the option number (A = amber, B = blue, C = clear, G = green, R = red, W = white) (e.g., 4RG is a red ON and green OFF pilot light).

Clear and white are not available for Bulletin 800T LED type pilot lights.

White is not available on Bulletin 800F incandescent pilot lights.

Clear is not available on Bulletin 800F LED pilot lights.

[3] When used with option 1F or 11DSA\_, option 90 (N.O. auxiliary contact) must be selected.

When used with option 1F and 11DSA3, option 900 (2 N.O. auxiliary contacts) must be selected.

[4] SC delivery for 110-120V control voltage. PE delivery for 220-240V control voltage.

Bulletin 800F pilot lights cannot be used with common (line voltage) control.

[5] Option 91 (1 N.C. auxiliary contact) must be selected.

When used with option 1F or 11DSA\_, option 901 (1 N.O. and 1 N.C. auxiliary contact) must be selected.

When used with option 1F and 11DSA3, option 9001 (2 N.O. and 1 N.C. auxiliary contacts) must be selected.

[6] When ON and OFF or ON and OVERLOAD pilot lights are selected in conjunction with push buttons, and control type is separate control or transformer control, the pilot lights will be Bulletin 800F pilot lights and the push buttons will be Bulletin 800T.

[7] When used with option 11DSA\_ or 7FEC\_, option 90 (1 N.O. auxiliary contact) must be selected.

[8] Option 91 (1 N.C. auxiliary contact) must be selected. When used with option 11DSA\_ or 7FEC\_, option 901 (1 N.O. and 1 N.C. auxiliary contact) must be selected.

[9] When used with option 1F, 11DSA\_, 7FEE\_D, or 7FEC\_, option 90 (N.O. auxiliary contact) must be selected.

(NOTE: required option code for Bulletin 2112 and 2113 vacuum contactor starter units is 900111.)

When used with option 1F and 11DSA3, 7FEE\_D, or 7FEC\_, option 900 (2 N.O. auxiliary contacts) must be selected.

(NOTE: required option code for Bulletin 2112 and 2113 vacuum contactor starter units is 900111.)

[10] Option 91 (1 N.C. auxiliary contact) must be selected.

When used with option 1F, 11DSA\_, 7FEE\_D, or 7FEC\_, option 901 (1 N.O. and 1 N.C. auxiliary contact) must be selected.

(NOTE: required option code for Bulletin 2112 and 2113 vacuum contactor starter units is 900111.)

When used with option 1F and 11DSA3, 7FEE\_D, or 7FEC\_, option 9001 (2 N.O. and 1 N.C. auxiliary contacts) must be selected.

(NOTE: required option code for Bulletin 2112 and 2113 vacuum contactor starter units is 900111.)

[11] When used with option 11DSA\_ or 7FEE\_DEE\_D, option -90 (1 N.O. auxiliary contact) must be selected.

[12] Option 91 (1 N.C. auxiliary contact) must be selected.

When used with option 11DSA\_ or 7FEE\_DEE\_D, option -901 (1 N.O. and 1 N.C. auxiliary contact) must be selected.

[13] Option 91 (1 N.C. auxiliary contact) must be selected.

[14] When a eutectic alloy overload relay is used, option 9 (N.O. overload relay auxiliary contact) must be selected. Not available with option 11DSA3, 7FEE\_D, or 7FEC\_.

## Factory-Installed Options, Modifications, Accessories for Contactors and Starters, Metering, Mains and Feeders, Lighting and Power Panels, Transformer and Miscellaneous Units

Multiple option numbers are separated by a dash and added to the base catalog number in ascending order.

### Pilot Lights (Push-To-Test)

- When selected, option 85T (Elapsed Time Meter) occupies the space of one Bulletin 800T (or 800H) pilot device or the space of two Bulletin 800F pilot devices, reducing the number of other devices which may be selected.
- Bulletin 800T pilot lights are transformer type, Bulletin 800F pilot lights are full-voltage type.
- When three or less devices are selected, pilot devices supplied are Bulletin 800T (800H for selector switches).
- When more than three devices are selected, pilot devices supplied are Bulletin 800F.
- On 0.5 space factor units, pilot devices supplied are Bulletin 800F, maximum of four (4) pilot devices may be selected.
- On dual mounted units, pilot devices supplied are Bulletin 800T (800H for selector switches), maximum of three (3) pilot devices may be selected.
- Legend plates are available in French or Spanish at no additional cost by adding 860F or 860S to catalog string number.

140

Description	FVC	FVR	FVNR	TS1W TS2W	TSR1W TSR2W	TSR1W TSR2W	Incandescent Lamps <sup>[1]</sup>	L.E.D. Lamps	Delivery Program
	2102L 2103L	2106 2107	2112 2113	2122 2123	2126E 2127E 2126F 2127F	2126J 2127J 2126K 2127K	Option Number <sup>[2]</sup>	Option Number <sup>[2]</sup>	
ON <sup>[3]</sup>	✓						-5_	-5L_	SC <sup>[4]</sup>
ON -OFF <sup>[5],[6]</sup>	✓						-5__	-5L__	
FORWARD - REVERSE <sup>[7]</sup>		✓					-5__	-5L__	
FORWARD - REVERSE - OFF <sup>[8]</sup>		✓					-5___	-5L___	
ON <sup>[9]</sup>			✓				-5_	-5L_	
ON -OFF <sup>[6],[10]</sup>			✓				-5__	-5L__	
HIGH - LOW <sup>[11]</sup>				✓			-5__	-5L__	
FAST - SLOW <sup>[11]</sup>				✓			-5E__	-5EL__	
HIGH - LOW - OFF <sup>[12]</sup>				✓			-5___	-5L___	
FAST - SLOW - OFF <sup>[12]</sup>				✓			-5E___	-5EL___	
HIGH - LOW - FORWARD - REVERSE					✓	✓	-5_____	--	
FAST - SLOW - FORWARD - REVERSE					✓	✓	-5E_____	--	
HIGH - LOW - FORWARD - REVERSE - OFF <sup>[13]</sup>					✓	✓	-5_____	--	
FAST - SLOW - FORWARD - REVERSE - OFF <sup>[13]</sup>					✓	✓	-5E_____	--	
OVERLOAD <sup>[14]</sup>		✓	✓ <sup>[3]</sup>	✓	✓	✓	-5T_	-5TL_	

10

[1] Bulletin 800F incandescent lamps are only available for 110-120VAC separate or transformer control.  
 [2] Option numbers are not complete, select pilot light lens color, add letter(s) to the option number (A = amber, B = blue, C = clear, G = green, R = red, W = white) (e.g., 4RG is a red ON and green OFF pilot light).  
 Clear and white are not available for Bulletin 800T LED type pilot lights.  
 White is not available on Bulletin 800F incandescent pilot lights.  
 Clear is not available on Bulletin 800F LED pilot lights.  
 [3] When used with option 1F or 11DSA\_, option 90 (N.O. auxiliary contact) must be selected.  
 When used with option 1F and 11DSA3, option 900 (2 N.O. auxiliary contacts) must be selected.  
 [4] SC delivery for 110-120V control voltage. PE delivery for 220-240V control voltage.  
 Bulletin 800F pilot lights cannot be used with common (line voltage) control.  
 [5] Option 91 (1 N.C. auxiliary contact) must be selected.  
 When used with option 1F or 11DSA\_, option 901 (1 N.O. and 1 N.C. auxiliary contact) must be selected.  
 When used with option 1F and 11DSA3, option 9001 (2 N.O. and 1 N.C. auxiliary contacts) must be selected.  
 [6] When ON and OFF or ON and OVERLOAD pilot lights are selected in conjunction with push buttons, and control type is separate control or transformer control, the pilot lights will be Bulletin 800F pilot lights and the push buttons will be Bulletin 800T.  
 [7] When used with option 11DSA\_ or 7FEC\_, option 90 (1 N.O. auxiliary contact) must be selected.  
 [8] Option 91 (1 N.C. auxiliary contact) must be selected.  
 When used with option 11DSA\_ or 7FEC\_, option 901 (1 N.O. and 1 N.C. auxiliary contact) must be selected.  
 [9] When used with option 1F, 11DSA\_, 7FEE\_D, or 7FEC\_, option 90 (N.O. auxiliary contact) must be selected.  
 (NOTE: required option code for Bulletin 2112 and 2113 vacuum contactor starter units is 900111.)  
 When used with option 1F and 11DSA3, 7FEE\_D, or 7FEC\_, option 900 (2 N.O. auxiliary contacts) must be selected.  
 (NOTE: required option code for Bulletin 2112 and 2113 vacuum contactor starter units is 900111.)  
 [10] Option 91 (1 N.C. auxiliary contact) must be selected.  
 When used with option 1F, 11DSA\_, 7FEE\_D, or 7FEC\_, option 901 (1 N.O. and 1 N.C. auxiliary contact) must be selected.  
 (NOTE: required option code for Bulletin 2112 and 2113 vacuum contactor starter units is 900111.)  
 When used with option 1F and 11DSA3, 7FEE\_D, or 7FEC\_, option 9001 (2 N.O. and 1 N.C. auxiliary contacts) must be selected.  
 (NOTE: required option code for Bulletin 2112 and 2113 vacuum contactor starter units is 900111.)  
 [11] When used with option 11DSA\_ or 7FEE\_DEE\_D, option -90 (1 N.O. auxiliary contact) must be selected.  
 [12] Option 91 (1 N.C. auxiliary contact) must be selected.  
 When used with option 11DSA\_ or 7FEE\_DEE\_D, option -901 (1 N.O. and 1 N.C. auxiliary contact) must be selected.  
 [13] Option 91 (1 N.C. auxiliary contact) must be selected.  
 [14] When a eutectic alloy overload relay is used, option 9 (N.O. overload relay auxiliary contact) must be selected.  
 Not available with option 11DSA3, 7FEE\_D, or 7FEC\_.

## Factory-Installed Options, Modifications, Accessories for Contactors and Starters, Metering, Mains and Feeders, Lighting and Power Panels, Transformer and Miscellaneous Units

Multiple option numbers are separated by a dash and added to the base catalog number in ascending order.

141

Option	Option Number	Description	Size or Rating	FVC	Size or Rating	FVR	FVNR	TS1W TS2W	TSR1W TSR2W	Delivery Program
				2102L 2103L		2106 2107	2112 2113	2122 2123	2126 2127	
				VA		VA	VA	VA	VA	
Control Circuit Transformer (with grounded and fused secondary)	-6P [1]	Standard capacity with primary fusing	30A	80 [2]	1	80	80 [2]	80	130	SC
			60A	80	2	80	80	80	200	
			100A	200	3	200	200	200	—	
			200A	250	4	250	250	250	—	
			300A	350	5	350	350	350	—	
			—	—	6	—	80	—	—	
			—	—	200A and 400A	—	250	—	—	
	—	—	600A	—	500	—	—			
	-6XP [3],[1]	100 watt extra capacity with primary fusing	30A	130	1	130	130	130	200	
			60A	130	2	130	130	130	250	
			100A	250	3	250	250	250	—	
			200A	350	4	350	350	350	—	
			300A	500	5	500	500	500	—	
			—	—	6	—	130	—	—	
—			—	200A and 400A	—	350	—	—		
—	—	600A	—	750	—	—				

[1] When a control circuit transformer is selected on dual 2103L and 2113 units, one auxiliary contact mounting position (P3) is given up for the transformer secondary fuse.

[2] For 0.5 space factor 2102L, 2103L, 2112 and 2113, standard capacity VA rating is 75VA.

[3] Not available on 0.5 space factor units.

## Factory-Installed Options, Modifications, Accessories for Contactors and Starters, Metering, Mains and Feeders, Lighting and Power Panels, Transformer and Miscellaneous Units

Multiple option numbers are separated by a dash and added to the base catalog number in ascending order.

142

Option	Option Number	Description	FVC	FVR	FVNR	TS1W TS2W	TSR1W TSR2W	TSR1W TSR2W	Delivery Program
			2102L 2103L	2106 2107	2112 2113	2122 2123	2126E 2127E 2126F 2127F	2126J 2127J 2126K 2127K	
E1 Plus Electronic Overload Relay <sup>(1),(2)</sup>	-7FEE_ <sup>(3)</sup>	Selectable trip class (10, 15, 20, 30) selectable Auto/Manual-Auto reset electronic overload relay for NEMA starters, Size 1-6.  Vacuum Contactor Starters	NEMA Size 1, 2		✓	✓			
			NEMA Size 3			✓ <sup>dual</sup> <sup>(4)</sup> <sub>(5)</sub>	✓ <sup>(5)</sup>	✓ <sup>(5)</sup>	
			NEMA Size 4		✓ <sup>(6)</sup>	✓ <sup>(7)</sup>			
			NEMA Size 5		✓	✓			
			NEMA Size 6			✓			
			200A, 400A, 600A				✓		
E1 Plus Electronic Overload Relay with DeviceNet module <sup>(1),(2),(8)</sup>	-7FEE_D <sup>(3)</sup>	Selectable to class (10, 15, 20, 30) selectable Auto/Manual-Auto reset electronic overload relay NEMA starters, Size 1-6. Includes DeviceNet module with (2) 24VDC inputs and (1) 110-240VAC output.  Vacuum Contactor Starters	NEMA Size 1, 2			✓ <sup>dual</sup> <sup>(4)</sup> <sub>(5)</sub>	✓ <sup>(5)</sup>		
			NEMA Size 3			✓		✓ <sup>(5)</sup>	
			NEMA Size 4			✓ <sup>(7)</sup>			
			NEMA Size 5			✓			
			NEMA Size 6			✓			
			200A, 400A, 600A				✓		
E1 Plus Electronic Overload Relay with Ground Fault Protection Module & Jam Protection <sup>(1),(2),(9),(10)</sup>	-7FEE_G <sup>(3)</sup>	Selectable to class (10, 15, 20, 30) selectable Auto/Manual-Auto reset electronic overload relay for NEMA starters, Size 1-3. Includes Ground Fault Protection Module with integral Jam Protection and external Ground Fault Sensor.  Vacuum Contactor Starters	NEMA Size 1, 2		✓	✓ <sup>(11)</sup>			
			NEMA Size 3		✓ <sup>(12)</sup>	✓ <sup>(12)</sup>			
			NEMA Size 4		✓ <sup>(13)</sup>	✓ <sup>(14)</sup>			
			NEMA Size 5		✓	✓ <sup>(15)</sup>			
			NEMA Size 6		✓	✓ <sup>(16)</sup>			
			200A 400A, 600A				✓		
E1 Plus with Jam Protection Module <sup>(1),(2),(10)</sup>	7FEE_J <sup>(3)</sup>	Selectable trip class (10, 15, 20, 30) selectable Auto/Manual-Auto reset electronic overload relay for NEMA starters, size 1-6 with Jam Protection Module  Vacuum Contactor Starters	NEMA Size 1, 2		✓	✓ <sup>dual</sup> <sup>(4)</sup> <sub>(5)</sub>	✓ <sup>(5)</sup>	✓ <sup>(5)</sup>	✓ <sup>(5)</sup>
			NEMA Size 3		✓	✓			✓ <sup>(5)</sup>
			NEMA Size 4		✓ <sup>(6)</sup>	✓ <sup>(7)</sup>			
			NEMA Size 5		✓	✓			
			NEMA Size 6			✓			
			200A, 400A, 600A				✓		

10

SC

- [1] Options -7FEE\_, 7FEE\_D, 7FEE\_G and 7FEE\_J are supplied with (1) N.O. and (1) N.C. auxiliary contact.
- [2] Options -7FEE\_, 7FEE\_D, 7FEE\_G and 7FEE\_J are mutually exclusive with each other and E3 overload relay options.
- [3] Option number is not complete:  
Select overload relay code from appropriate table on 112 and add to option number (e.g., 7FEE**B**).
- [4] Not available on NEMA Size 2 dual units.
- [5] For two-speed starter and dual mounted starter units, there are two overload option codes required (e.g., 7FEE**EEEB**, with DeviceNet module 7FEE**EDEEBD**, with Jam Protection module 7FEE**EJEEBJ**).  
For two-speed applications, the first code denotes the high speed overload relay and the second code denotes the low speed overload relay.  
For dual unit applications, the first code denotes the left-side overload relay, the second code denotes the right-side overload relay.
- [6] Bulletin 2106 NEMA Size 4 will be increased to 4.5 space factor.
- [7] Bulletin 2112 NEMA 4 with Class J or HRCII-C fuses will be increased to 3.0 space factor. Bulletin 2113 Size 4 with circuit breaker option -CT or -CM requires 3.0 space factor.
- [8] Mutually exclusive with 89\_ relay and 87\_ auxiliary timer options. Not available with pushbuttons or selector switches, except 3 and 1F are allowed for Bulletin 2112 and 2113. Separate or transformer control only. Not available with option 11DSA2 or 11DSA3.
- [9] Not available on dual starter units or with option 85XA (current transformer), 85AA (ammeter) or 700TC\_ (current transducer).
- [10] Available for separate, transformer, or line-to-neutral control only; not available with common control.
- [11] Not available on 0.5 space factor units with option 11DSA2 or 11DSA3.
- [12] NEMA size 3, power terminal blocks must be supplied. Not available with Type A wiring or option 106 (omission of power terminal blocks).
- [13] Bulletin 2107, NEMA Size 4 with circuit breaker suffix CT or CM will be increased to 4.5 space factor.
- [14] Bulletin 2112, NEMA Size 4 will be increased to 3.5 space factor. Bulletin 2113, NEMA Size 4 with circuit breaker suffix CA will be increased to 2.5 space factors.
- [15] Bulletin 2112, NEMA Size 5 with Class J fuse clips will be increased to 4.0 space factor.
- [16] Not available for 200HP at 240V or 400HP at 480V.

## Factory-Installed Options, Modifications, Accessories for Contactors and Starters, Metering, Mains and Feeders, Lighting and Power Panels, Transformer and Miscellaneous Units

### Overload Relay Codes for E1 Plus, Option -7FEE\_, -7FEE\_D, -7FEE\_G, or 7FEE\_J

143

For Use with NEMA Size	Full Load Current Range (Amperes)	Overload Relay Code (Add to Option Number from 111 [e.g., 7FEEB]) <sup>[1]</sup>
1 <sup>[2]</sup>	0.2 - 1.0	B
	1.0 - 5.0	C
	3.2 - 16	D
	5.4 - 27	E
2 <sup>[3]</sup>	9 - 45	F
3	18 - 90	G
4	30 - 150	H
5	60 - 300	J
6	120 - 600	K
200A Vacuum Contactor Starter	40 - 200	L
400A Vacuum Contactor Starter <sup>[4]</sup>	60 - 300	J
400A Vacuum Contactor Starter <sup>[4]</sup>	100 - 500	M
600A Vacuum Contactor Starter	120 - 600	K

[1] For two-speed starter and dual mounted starter units, there are two overload option codes required (e.g., 7FEEEEE**B**, with DeviceNet module 7FEEDEE**BD**, with Jam Protection module 7FEE**E**JEE**B**J). For two-speed applications, the first code denotes the high speed overload relay and the second code denotes the low speed overload relay. For dual mounted starter units, the first code denotes the overload relay for the left-hand starter, the second code denotes the overload relay for the right-hand starter. If a DeviceNet module or Jam protection module is selected, it must be added to both overload relay codes and be the same option, either DeviceNet or Jam protection for both codes.

[2] Not available on NEMA Size 1 dual units when option 7FEE\_ **G** (ground fault protection) is used.

[3] Not available on NEMA Size 2 dual units.

[4] 400A Vacuum Contactor Starters use code "J" except 125HP@208V, 125 - 150HP@240V, 250HP@380-415V, 250 - 300HP@480V, and 350 - 400HP@600V use code "M"

# Factory-Installed Options, Modifications, Accessories for Contactors and Starters, Metering, Mains and Feeders, Lighting and Power Panels, Transformer and Miscellaneous Units

Multiple option numbers are separated by a dash and added to the base catalog number in ascending order.

Option	Option Number	Description	FVC	FVR	FVNR	TS1W TS2W	TSR1W TSR2W	TSR1W TSR2W	Delivery Program
			2102L 2103L	2106 2107	2112 2113	2122 2123	2126E 2127E 2126F 2127F	2126J 2127J 2126K 2127K	
E3 Electronic Overload Relay <sup>[1],[2]</sup>  For non-DeviceNet applications a 24VDC separate power source is needed. A Bulletin 193-DNCT, may be needed for programming and monitoring. Refer to publication, 193-UM001.x-EN-P.	-7FEC1_ <sup>[3]</sup>	E3 Basic is provided with two (2) 24VDC inputs and one (1) 110-240VAC output.	NEMA size 1			✓ <sup>[4]</sup>			SC
			NEMA size 2			✓ <sup>[5]</sup>			
			NEMA size 3			✓			
			NEMA size 4			✓ <sup>[6]</sup>			
			NEMA size 5			✓			
			NEMA size 6			✓			
	-7FEC2_ <sup>[3]</sup>	E3 Plus is provided with four (4) 24VDC inputs and two (2) 110-240VAC outputs.	Vacuum Contactor Starters			✓			
			NEMA size 1		✓	✓ <sup>[4]</sup>			
			NEMA size 2		✓	✓ <sup>[5]</sup>			
	7FEC3_ <sup>[3],[7]</sup>	E3 Plus is provided with four (4) 24VDC inputs and two (2) 110-240VAC outputs.	NEMA size 3		✓	✓			
			NEMA size 4		✓ <sup>[8]</sup>	✓ <sup>[6]</sup>			
			NEMA size 5		✓	✓			
NEMA size 6					✓				
		Vacuum Contactor Starters			✓				

- [1] Outputs are rated NEMA B300 (3A @ 120VAC and 1.5A @ 240VAC). Not available with common (line voltage) control. Not available with Type A wiring. Not available on dual 2113, 0.5 space factor 2112 and 0.5 space factor 2113 units.
- [2] Mutually exclusive with E1 Plus overload relays (options -7FEE\_, 7FEE\_D, 7FEE\_G and 7FEE\_J). Mutually exclusive with option 9 & 9A, 11DSA\_, 18, 84A1, 85XA & 85AA, 87\_, 89\_, and 700TC\_.
- [3] Catalog numbers listed are not complete:
  - Select overload relay code from table below and add to option number (e.g., 7FEC2B).
  - For NEMA size 1-3 overload relays, if 120VAC inputs are required, place a "Y" configuration option in the catalog string number as in table below (e.g., 7FEC2BY).
  - If applicable for NEMA size 4-6 and vacuum contactor starters, select an E3 overload relay configuration option from table below, add to option number (e.g., 7FEC3FY, 120VAC input points).
- [4] NEMA size 1 2112/2113 1.0 space factor units are limited to 10 control terminal points and 3 power terminal points. When option 106 (eliminate power terminals) is used, up to 15 control terminal points are available. For 20 control terminal points, add 0.5 space factor.
- [5] NEMA size 2 2112/2113 1.0 space factor units are limited to 10 control terminal points and 3 power terminal points. Option 106 (eliminate power terminals) is not available for NEMA size 2 2112/2113 units. For 15 to 20 control terminal points, add 0.5 space factor.
- [6] Bulletin 2112, NEMA Size 4, with Class J or HRCII-C fuses will be increased to 3.0 space factors. Bulletin 2113, NEMA Size 4, with circuit breaker suffix "CT" or "CM" will be increased to 3.0 space factors.
- [7] NEMA size 1-3 E3 Plus overload relays have ground fault sensor as standard. NEMA size 4-6 E3 Plus overload relays and vacuum contactor starters need to have the ground fault configured to include a ground fault sensor. Refer to E3 overload relay configuration options table below.
- [8] Bulletin 2106, NEMA Size 4 will be increased to 4.5 space factors.

10

### Overload Relay Codes for E3 and E3 Plus, Option 7FEC\_ 145

For use with NEMA Size	Full Load Current Range (Amperes)	Overload Relay Code (Add to Option Number [e.g., 7FEC1A])
1	0.4-2.0	P
	1-5	A
	3-15	B
	5-25	C
2	9-45	D
3	18-90	E
4	28-140	F
5	60-302	H
6	125-630	K
200A Vacuum Contactor Starter	42 - 210	G
400A Vacuum Contactor Starter <sup>[1]</sup>	60 - 302	H
400A Vacuum Contactor Starter <sup>[1]</sup>	84 - 420	M
600A Vacuum Contactor Starter	125 - 630	K

[1] 400A Vacuum Contactor Starters use code "H" except 125HP@208V, 125 - 150HP@240V, 250HP@380-415V, 250 - 300HP@480V, and 350 - 400HP@600V use code "M"

### E3 Overload Relay Configuration Options 146

Description	Overload Relay Code (Add to option number [e.g., 7FEC3FYG])
24VDC input points	None
120VAC input points, available for 110-120VAC control voltage only	Y
Ground fault. Includes Bulletin 193-CBCT3 or 193-CBCT4 ground fault sensor.	G <sup>[1], [2]</sup>
120VAC input points and ground fault (see description above)	YG <sup>[1], [2]</sup>

- [1] Only available for E3 Plus overload relays for NEMA Size 4, 5 and 6 and vacuum contactor starters.
- [2] Bulletin 2112, NEMA Size 4 will be increased to 3.5 space factor. Bulletin 2113, NEMA Size 4 with circuit breaker suffix CA will be increased to 2.5 space factors. Bulletin 2112, NEMA Size 5 with Class J fuse clips will be increased to 4.0 space factor. Bulletin 2107, NEMA Size 4, with circuit breaker suffix "CT" or "CM" will be increased to 4.5 space factors. Bulletin 2112, NEMA Size 5, with Class J fuses will be increased to 4.0 space factors.

## Factory-Installed Options, Modifications, Accessories for Contactors and Starters, Metering, Mains and Feeders, Lighting and Power Panels, Transformer and Miscellaneous Units

Multiple option numbers are separated by a dash and added to the base catalog number in ascending order.

147

Option	Option Number	Description	FVC	FVR	FVNR	TS1W TS2W	TSR1W TSR2W	TSR1W TSR2W	Feeder/ Main	Delivery Program	
			2102L 2103L	2106 2107	2112 2113	2122 2123	2126E 2127E 2126F 2127F	2126J 2127J 2126K 2127K	2192 2193		
Overload Relay Auxiliary Contact (Eutectic Alloy)  (one contact per overload relay) <sup>[1]</sup>	-9	Normally Open	Type A Wiring		✓	✓		✓	✓		SC
			Type B Wiring		✓	✓		✓	✓		
	-9A	Normally Closed	Type A Wiring		✓	✓		✓	✓		
			Type B Wiring		✓	✓		✓	✓		
DeviceNet Starter Auxiliary (DSA) <sup>[2],[3]</sup>	-11DSA2	For use with contactors and starters to provide DeviceNet inputs and outputs. <b>(4) 120V</b> inputs and (2) 120V outputs. Available for 110V-120V control only.	✓	✓	✓	✓			✓ [4],[5],[6]		
	-11DSA3	For use with contactors and starters to provide DeviceNet inputs and outputs. <b>(4) 24VDC</b> inputs and (2) 240VAC (max), 30VDC (max) outputs. Available for 110V-120VAC or 220V-240VAC control voltage.	✓	✓	✓	✓			✓ [5],[6]		
Additional Unit Space	-15	Adds 0.5 space factor unit space to Bulletin 2112 and 2113 size 1, 2 and 3 units. <b>Note:</b> Bulletin 2112 and 2113, sizes 1 and 2, cannot be increased from 1.5 to 2.0 space factors by selecting option 15, nor can size 1 increase from 0.5 to 1.0 space factor by using option 15.			✓						
Filters for Door Vents	-16A	Filters for door vents on NEMA Type 1 and NEMA Type 1 with gasket Bulletin 2195, 2196 and 2197 units	Available on NEMA Type 1 and NEMA Type 1 with gasket Bulletins 2195, 2196 and 2197 only								
Surge Suppressor <sup>[7]</sup>	-17 <sup>[8]</sup>	On coil, one per contactor, for starters and contactors, not available on vacuum type, selection of this option requires the selection of -17R if an option relay (89__ ) is also selected.	✓		✓						SC
				✓		✓		✓	✓		
	-17R	For units with interposing relays (89CB and 89CBL) and unwired control relays (89CF and 89P), may only be used if option relay (89__ ) is selected. Selection of this option requires selection of option -17. Except when 89CBL or Common Control is selected.	✓		✓			✓	✓		
O/L Contact on Left Side of Circuit	-18 <sup>[9]</sup>	Moves overload trip contact from right (grounded) side of the control circuit to left (power input) side of control circuit.		✓	✓	✓					
Omit Wiring	-19	Omission of control wiring <sup>[10]</sup>	✓	✓	✓	✓	✓	✓	✓		
Control Circuit Fuse	-21	One (1) control circuit fuse for separate control or line to neutral control	✓	✓	✓	✓	✓	✓	✓		
	-22	Two (2) control circuit fuses for common control	✓	✓	✓	✓	✓	✓	✓	PE	

[1] Options 9 and 9A are mutually exclusive and not available with optional overload relays (-7F\_\_ ).

[2] Not available for dual 2103L or dual 2113 units. Not available for 0.5 space factor 2103L units. Not available for 0.5 space factor 2112 or 0.5 space factor 2113 units with E1 Plus with ground fault/jam protection (option 7FEE\_G) or E1 Plus with jam protection (option 7FEE\_J). Not allowed for 0.5 space factor 2113 units with eutectic overload relay. Mutually exclusive with 89\_\_ relay and 87 timer options. Not available with push buttons or selector switches, except options 3 and 1F are allowed for Bulletin 2102L, 2103L, 2112 and 2113.

[3] DeviceNet options 11DSA2 and 11DSA3 are mutually exclusive. Not available with 7FEE\_D. Not available for 2193F single or dual mounted when one or both trip code '00' is used. Mutually exclusive with E3 overload relays, option 7FEC\_\_.

[4] A 120/240VAC source must be provided.

[5] Bulletins 2192F and 2192M require option 98 (external N.O. auxiliary contact). Bulletins 2193F and 2193M require option 98 (N.O. external auxiliary contact) or 98X (N.O. internal auxiliary contact).

[6] Not available with dual 2192F units.

[7] Available for 110-240V control voltage. SC delivery for 110-120V control voltage. PE delivery for 220-240V control voltage. Not available for common control.

[8] Options 17 and 89CBL are mutually exclusive.

[9] Not available with option -7FEC\_\_.

[10] Except primary wiring to control transformers. On units where the control transformer is inaccessible (e.g. installed under a mounting bracket), the transformer secondary 'x1' will be wired to the transformer secondary fuse and the transformer secondary 'x2' will be grounded and wired to the coil on Bulletin 2102 or 2103 units, to the coil on the starter units when option -18 is selected, to the normally closed overload relay auxiliary contact on the starter units when option -18 is not selected.

## Factory-Installed Options, Modifications, Accessories for Contactors and Starters, Metering, Mains and Feeders, Lighting and Power Panels, Transformer and Miscellaneous Units

Multiple option numbers are separated by a dash and added to the base catalog number in ascending order.

148

Option	Option Number	Description	FVC	FVR	FVNR	TS1W TS2W	TSR1W TSR2W	TSR1W TSR2W	Delivery Program
			2102L 2103L	2106 2107	2112 2113	2122 2123	2126E 2127E 2126F 2127F	2126J 2127J 2126K 2127K	
Blown Fuse Indicator Lights	-4BF	Option 4BF is valid only when 480V and 600V Power Factor Correction Capacitor is selected				✓			PE-II
480V and 600V Power Factor Correction Capacitors <sup>[1],[2]</sup>  (Refer to publication 2100-AT001x-EN-P, <i>Power Factor Correction Capacitors for CENTERLINE 2100 MCC Starter Units</i> , for more information)	-30KV	2 kVAR through 40 kVAR in 0.5 space factor. <sup>[3]</sup>	2 kVAR			✓			
	-31KV		2.5 kVAR			✓			
	-32KV		3 kVAR			✓			
	-33KV		4 kVAR			✓			
	-34KV		5 kVAR			✓			
	-35KV	42.5 kVAR through 50 kVAR in 1.0 space factor. <sup>[3]</sup>	6 kVAR			✓			
	-36KV		7 kVAR			✓			
	-37KV		7.5 kVAR			✓			
	-38KV	These capacitors should not be used on motors subject to plugging or jogging. Do not subject capacitors to repetitive switching where capacitors and motors might be reenergized too quickly after being de-energized.	8 kVAR			✓			
	-39KV		9 kVAR			✓			
	-40KV		10 kVAR			✓			
	-41KV		11 kVAR			✓			
	-42KV		12.5 kVAR			✓			
	-43KV		13.5 kVAR			✓			
	-44KV		15 kVAR			✓			
	-45KV	Do not install capacitors in any vertical section that contains a variable frequency drive.	16 kVAR			✓			
	-46KV		17.5 kVAR			✓			
	-47KV		18 kVAR			✓			
	-48KV	Capacitors are mounted in separate unit with a separate door. This unit is located below selected starter. Door interlock is included. Three phase power fuses are included.	20 kVAR			✓			
	-49KV		22.5 kVAR			✓			
-50KV	25 kVAR				✓				
-51KV	27.5 kVAR				✓				
-52KV	Capacitors are factory wired to load side of the contactor and on the line side of the overload relay.	30 kVAR			✓				
-53KV		32.5 kVAR			✓				
-54KV		35 kVAR			✓				
-55KV		37.5 kVAR			✓				
-56KV		40 kVAR			✓				
-57KV		42.5 kVAR			✓				
-58KV		45 kVAR			✓				
-59KV	50 kVAR			✓					

10

[1] See option 4BF for optional blown fuse indicators. Not available on dual starters, 0.5 space factor units, 6.0 space factor units or Space Saving NEMA units or vacuum contactor starters. Refer to Recommended Capacitor Size table in Appendix for suggested capacitor ratings.  
 [2] For applications other than motor applications connected to the load side of the starter or for those applications outlined in publication 2100-AT001x-EN-P, contact your local Rockwell Automation Sales Office.  
 [3] At 600V, 37.5 kVAR to 50 kVAR are 1.0 space factor

## Factory-Installed Options, Modifications, Accessories for Contactors and Starters, Metering, Mains and Feeders, Lighting and Power Panels, Transformer and Miscellaneous Units

Multiple option numbers are separated by a dash and added to the base catalog number in ascending order.

149

Option	Option Number	Description	FVC	FVR	FVNR	TS1W TS2W	TSR1W TSR2W	TSR1W TSR2W	Delivery Program	
			2102L 2103L	2106 2107	2112 2113	2122 2123	2126E 2127E 2126F 2127F	2126J 2127J 2126K 2127K		
Grounded Unit Door	-79GD	Hinge mounted ground strap mounted on bottom hinge of unit door. Unit door hinge grounding strap for IEC requirements.	Available on all units							SC
Unit Load Connector	-79L	Select on all plug-in units in sections with vertical unit load ground bus	Unplated copper		Available on all plug-in units					
	-79LT		Tin plated copper							
Unit Ground Stab	—	Copper unit ground stabs also may be used with steel vertical ground bus. Select on plug-in units in sections with vertical plug-in ground bus.	Copper alloy		Available on all plug-in units					
	-79U		Unplated copper							
	-79UT		Tin plated copper							
Thermistor Protection Relay <sup>[1],[2]</sup>	-84A1	Bulletin 817-E2P, 110 - 120VAC, 50-60 Hz, output is unwired.			✓					
Unit Ammeter <sup>[3],[4],[2]</sup>	-85AA	Analog ammeter and current transformer.		✓	✓					
	-85XA	Current transformer only for use with external meter. Current transformer rated 2.5VA or greater.		✓	✓					
Elapsed Time Meter <sup>[5],[6],[7]</sup>	-85T	Six digit non-resettable meter (with tenths), mounted in control station	✓		✓					
Unwired Timer Auxiliary (not available on 0.5 SF units)	-87A	Bulletin 596 time delay addition to NEMA size 1 through 5 contactors with N.O. and N.C. contacts. Not available with -7FEC_E3.	On delay			✓				
	-87B		Off delay			✓				
Ground Detection Lights <sup>[8]</sup>	-88A	Three (3) Bulletin 800T pilot lights (clear), wired in grounded WYE, complete with fusing	240 Volt		Available on Bulletin 2191M, 2192M and 2193M ONLY Not for use with solidly grounded power systems					
	-88B		480 Volt							
	-88C		600 Volt							
	-88H		208 Volt							
	-88I		415 Volt							
	-88KN		400 Volt							
	-88N		380 Volt							
	-88AT	Three (3) Bulletin 800T push-to-test pilot lights (clear), wired in grounded WYE, complete with fusing	240 Volt		Available on Bulletin 2191M, 2192M and 2193M ONLY Not for use with solidly grounded power systems					
	-88BT		480 Volt							
	-88CT		600 Volt							
	-88HT		208 Volt							
	-88IT		415 Volt							
	-88KNT		400 Volt							
	-88NT		380 Volt							
Ground Fault Protection <sup>[9]</sup>	-88GF	Integral ground fault protection system with adjustable pick-up, adjustable time delay, control power indicator light, trip indicator and built-in test feature. Shunt trip is included. See required voltage code on 70.	Only available on Bulletin 2192M, 1600A-2000A. For use with solidly grounded WYE systems only.							PE-II

[1] Not available on dual starters, requires 1.5 space factor for size 1 and 2 and 2.0 space factor for 2113 size 3. Requires extra 0.5 space factor for NEMA Size 4 Bulletin 2112 with Class J and HRCII-C fuses. Requires 2.5 space factor for NEMA Size 4 Bulletin 2113 with MCP circuit breaker (Circuit Breaker code CA) and E1 Plus overload relay (Option 7FEE\_). Not available in units containing a current transducer (700TC\_). Available in Canada only. Available for 120V separate or transformer control only. Not available with E3 overload relay; for thermistor protection, use E3 Plus overload relay.

[2] 85XA, 85AA not available with 7FEE\_D or 7FEC\_.

[3] Ammeter has 5A movement, 3.5" scale, 102° deflection and 2% of full scale accuracy. Current transformer for external meter is supplied with 8-foot secondary leads. Ammeter scale and CT ratio are determined by the horsepower code. Not valid on 0.5 space factor or dual mounted units, units with E3 overload relay (7FEC\_) or units with E1Plus overload relay with ground fault/jam protection (option 7FEE\_G). Requires 2.5 space factor for NEMA Size 4 Bulletin 2113 with MCP circuit breaker (Circuit Breaker code CA) and E1 Plus overload relay (Option 7FEE\_).

[4] Unit ammeter and current transducer options are mutually exclusive.

[5] Elapsed time meter mounts in position normally used for a pilot device, limiting the maximum number of pilot devices selected. On 0.5 space factor units, elapsed time meter uses two positions normally used for a pilot device. Not available on dual mounted units. Available on units with 120 Volt separate or transformer control only. Not available on 380-415V, 50Hz applications.

[6] Mutually exclusive with control relay options 89CB, 89CBL, 89CF\_ and 89P in 1.0 space factor and current transformer options 700TC1 and 700TC4 in 1.0 space factor.

[7] Requires option -90, Normal open auxiliary contact for Bulletin 2102L, 2103L, 2112 and 2113. Requires option -900011 for Bulletin 2112 and 2113 vacuum contactor starters.

[8] Not available on Bulletin 2191M units specified with metering options. Not available on Bulletin 2191MT, 600A in horizontal wireway, corner section or 10" wide incoming lug section. Not available on non-fused 2192M units. Mutually exclusive with key interlock mounting provision (option 201).

[9] Horizontal neutral bus and incoming neutral bus is required when 3-phase, 4-wire power system is specified.

## Factory-Installed Options, Modifications, Accessories for Contactors and Starters, Metering, Mains and Feeders, Lighting and Power Panels, Transformer and Miscellaneous Units

Multiple option numbers are separated by a dash and added to the base catalog number in ascending order.

150

Option	Option Number	Description	Rating	Main Neutral Bus Location			Space Factor Adder			MLUG 2191M [1]	MFDS 2192M	MCB 2193M	Delivery Program	
				MLUG	MFDS	MCB	MLUG	MFDS	MCB					
Incoming Neutral Bus [2] For Bulletin 2191M (main lug) units. See table on page 64 for available lugs	-88HN_ (half-rated)	Provides for incoming neutral connection to horizontal neutral bus within the main incoming unit. Incoming neutral bus must match the horizontal neutral bus, rating, half or full.	600	[3]			None			✓			PE	
			800	[4]			None			✓				
			1200	[4]			None			✓				
			1600	[5]			None			✓				
			2000	[5]			None			✓				
	-88FN_ (full-rated)		600	[3]			None			✓				
			800	[4]			None			✓				
			1200	[4]			[4]			✓				
			1600	[5]			None			✓				
			2000	[5]			None			✓				
Incoming Neutral Bus [6] For Bulletins 2192M (main fusible disconnect switch) and 2193M (main circuit breaker). See tables on page 72 for 2192M and pages 79-80 for 2193M standard and optional lugs.	-88HN (half-rated)	Provides for incoming neutral connection to horizontal neutral bus within the main incoming unit. Incoming neutral bus must match the horizontal neutral bus, rating, half or full.	400		[7]	[7]		[8]	None		✓	✓	PE	
			600		[9]	[9]		1.0	1.0 [8]		✓	✓		
			800		[9]	[9]		1.0	1.0 [8]		✓	✓		
			1200		[9]	[9]		1.0	1.0		✓	✓		
			1600		[3]	N/A		None	N/A		✓	✓		
	-88FN (full-rated)		2000		[3]	[3]		None	None		✓	✓		
			150		N/A	[7]		N/A	None					✓
			225		N/A	[7]		N/A	None					✓
			400		[7]	[7]		[8]	None		✓	✓		
			600		[9]	[9]		1.0	1.0 [8]		✓	✓		
			800		[9]	[9]		1.0	1.0 [8]		✓	✓		
			1200		[9]	[9]		1.0	1.0		✓	✓		
			1600		[3]	N/A		None	N/A		✓	✓		
			2000		[3]	[3]		None	None		✓	✓		
Incoming Neutral Connection Plate [10]  (can be used only in sections with a vertical wireway)	-88NPC [11]	0.25" x 2" x 12" copper tin plated bus plate with #6-250 kcmil lug. Insulated from and mounted on unit support pan. Located below main incoming unit if top entry and located above main incoming unit if bottom entry. Adds 0.5 space factor for main unit if less than 6.0 space factor. Not available for 2191M unit in top horizontal wireway. 280A capacity.							✓[12]	✓[13]	✓[14]	SC-II		
	-88NPS [11]	0.25" x 2" x 12" copper silver plated bus plate with #6-250 kcmil lug. Insulated from and mounted on unit support pan. Located below main incoming unit if top entry and located above main incoming unit if bottom entry. Adds 0.5 space factor for main unit if less than 6.0 space factor. Not available for 2191M unit in top horizontal wireway. 280A capacity.							✓[12]	✓[13]	✓[14]	PE		

10

- [1] Not available with 600A incoming lug compartment in horizontal wireway, 300A incoming lug compartment or 10" wide section with incoming lugs.
- [2] Option code is not complete. Add location ('T' for the top, 'B' for the bottom) which matches the location of the horizontal neutral bus. Use 'T' for neutral bus above the main power bus. Use 'B' for neutral bus below the main power bus. **NOTE:** The code may be required to be opposite the code used on the Bulletin 2191 unit, e.g. 2191MT-DKC-54-88FNB.
- [3] Same as MLUG, MFDS, MCB (e.g., if MLUG, MFDS or MCB is in the top of the section, main neutral bus will be in top bus pocket).
- [4] Horizontal neutral must be located on the opposite side of the MLUG, except 6 space factor, the neutral bus location is unrestricted. 1200A full-rated neutral must be 6 space factor.
- [5] No restrictions.
- [6] Available in U.S. In Canada, contact your local Rockwell Automation Sales Office.
- [7] Top incoming only. Horizontal neutral must be located below the main power bus.
- [8] Adds 5" to width and eliminates vertical wireway.
- [9] Horizontal neutral must be located below the main power bus.
- [10] Can only be used in sections with a vertical wireway. Can not be used if horizontal neutral bus is selected. For applications with horizontal neutral bus, select the appropriate 88HN or 88FN option. If incoming neutral cable is greater than one, #6 AWG to 250 kcmil, or if neutral current will exceed 280A, do not use option 88NPC or 88NPS. Select horizontal neutral bus and appropriate 88HN or 88FN options.
- [11] Will increase unit size by 0.5 SF, mounted below main unit that is top mounted or mounted above main unit that is bottom mounted. Main unit and neutral unit doors are interlocked
- [12] May only be selected for 300A main incoming lug compartment. For ratings greater than 300A, use incoming neutral bus option (-88HN\_ or -88FN\_).
- [13] May only be selected for 400A and smaller main fusible disconnect switch. For ratings greater than 400A, use incoming neutral bus option (-88HN or -88FN).
- [14] May only be selected for 400A and smaller frame main circuit breaker. For frame ratings greater than 400A, use incoming neutral bus option (-88HN or -88FN).

# Factory-Installed Options, Modifications, Accessories for Contactors and Starters, Metering, Mains and Feeders, Lighting and Power Panels, Transformer and Miscellaneous Units

Option	Option Number	Description	FVC	FVR	FVNR	TS1W TS2W	TSR1W TSR2W	TSR1W TSR2W	Delivery Program
			2102L 2103L	2106 2107	2112 2113	2122 2123	2126E 2127E 2126F 2127F	2126J 2127J 2126K 2127K	
Interposing Relay [1]	-89CB	Control circuit interposing relay. Utilizes Bulletin 700-CF control relay to control starter coil in control circuit. Available on NEMA sizes 1 through 5 and vacuum contactor starters. The starter or contactor coil voltages and interposing relay coil voltages are the same as the control voltage.	✓		✓				SC [2]
Mutually exclusive with 89CF and 89P, unwired control relays	-89CBL [3]	Line circuit interposing relay. Utilizes Bulletin 700-CF control relay to control starter coil in control circuit. Available on NEMA sizes 1 through 5. The starter or contactor coil voltages are the same as the line voltage. The interposing relay coil voltage is the same as the control voltage.	✓	✓		✓			
				✓		✓			

[1] 2.0 space factor minimum when selected on Bulletin 2113 size 3 starters and Bulletin 2106 and 2107 size 1 or 2. Not available on dual 2103L, dual 2113 units or 0.5 space factor units. Not available with common control. Mutually exclusive with 7FEC\_ options, 11DSA2 or 11DSA3 DeviceNet starter auxiliary options or 7FEE\_D.

[2] SC delivery for 110-120V control voltage. PE delivery for 220-240V control voltage.

[3] Options 89CBL and 17 are mutually exclusive. When one (1) control circuit fuse for separate control (21) is selected with 89CBL on 1.0 space factor Bulletin 2102L, 2103L, 2112 or 2113 units, one (1) auxiliary contact mounting position (P3) is given up for the control circuit fuse.

## Factory-Installed Options, Modifications, Accessories for Contactors and Starters, Metering, Mains and Feeders, Lighting and Power Panels, Transformer and Miscellaneous Units

Multiple option numbers are separated by a dash and added to the base catalog number in ascending order.

152

Option	Option Number	Description	FVC	FVR	FVNR	TS1W TS2W	TSR1W TSR2W	TSR1W TSR2W	Delivery Program				
			2102L 2103L	2106 2107	2112 2113	2122 2123	2126E 2127E 2126F 2127F	2126J 2127J 2126K 2127K					
			QUANTITY SUPPLIED										
Unwired Control Relay <sup>[1]</sup>  Mutually exclusive with 89CB and 89CBL interposing relays  For common control, 120V coil is provided	-89CF40	Bulletin 700CF 4-pole relay <sup>[2]</sup>	4 N.O.						SC <sup>[3]</sup>				
	-89CF31		3 N.O. and 1 N.C.	1	2	1	2	4		4			
	-89CF22		2 N.O. and 2 N.C.										
	-89CF40A	Bulletin 700CF 4-pole relay with time attachment  0.3 to 30 seconds <sup>[4]</sup>	4 N.O.							PE			
	-89CF22A		2 N.O. and 2 N.C.	1	2	1	2	4			4		
	-89CF40B		4 N.O.										
	-89CF22B	2 N.O. and 2 N.C.											
	-89CF40C	Bulletin 700CF 4-pole relay with time attachment  1.8 to 180 seconds <sup>[4]</sup>	4 N.O.								SC <sup>[3]</sup>		
	-89CF22C		2 N.O. and 2 N.C.	1	2	1	2	4				4	
	-89CF40D		4 N.O.										
	-89CF22D	2 N.O. and 2 N.C.											
	-89CF40L	Bulletin 700CF 4-pole relay with mechanical latch attachment <sup>[4]</sup>	4 N.O.	1	2	1	2	4				4	PE
	-89CF22L		2 N.O. and 2 N.C.										
	-89P2	Bulletin 700P relay	2 N.O.	1	2	1	2	4				4	SC <sup>[3]</sup>
	-89P4		4 N.O.										
-89PT	Bulletin 700P with pneumatic time delay attachment (on/off delay) with two (2) timed contacts (0.1 to 60 seconds) <sup>[4]</sup>	No instantaneous contacts	1	2	1	2	4	4	PE				
-89PT2		2 N.O.											
-89PT4		4 N.O.											
-89PL2	Bulletin 700P with mechanical latch attachment <sup>[4]</sup>	2 N.O.	1	2	1	2	4	4					

10

[1] Not available on dual 2103L units, dual 2113 units or 0.5 space factor units. When selected on 2122 or 2123 size 1 or 2 starter units, power terminal blocks will not be provided. One (1) relay will be furnished per each contactor on reversing (2106/2107), two speed (2122/2123) and two-speed reversing (2126/2127) starters. Bulletin 2106 and 2107 size 1 and 2 starters and Bulletin 2113 size 3 starters require 2.0 space factors when a relay is selected. Mutually exclusive with 11DSA2 and 11DSA3 DeviceNet starter auxiliary, 7FEC\_\_ or 7FEE\_D.

[2] When control circuit transformer is selected on Bulletin 2102L or 2103L 30A or 60A units or Bulletin 2112 or 2113 size 1 or 2 units, the secondary control transformer fuse is mounted in one of the three starter auxiliary contact pockets.

[3] SC delivery for 110-120V control voltage. PE delivery for 220-240V control voltage.

[4] When selecting Bulletin 2102L or 2103L 30A or 60A units or Bulletin 2112 or 2113 size 1 and 2 starters, a 1.5 space factor unit is required.

# Factory-Installed Options, Modifications, Accessories for Contactors and Starters, Metering, Mains and Feeders, Lighting and Power Panels, Transformer and Miscellaneous Units

Multiple option numbers are separated by a dash and added to the base catalog number in ascending order.

153

Option	Option Number	Description	NEMA Size	Wiring Type	Misc. Units		FVC <sup>[1]</sup>		FVR		FVNR <sup>[1]</sup>		TS1W TS2W		TSR1W TSR2W		FDS		CB		Xfmr		Delivery Program		
					2100D	2100M	2102L	2103L	2106	2107	2112	2113	2122	2123	2126	2127	2192F	2192M	2193F	2193M	2196	2197			
Auxiliary Contacts <sup>[2]</sup>	-90	NORMALLY OPEN One (1) N.O. auxiliary contact mounted on each contactor or starter	1-6	A			✓	✓				✓	✓		✓	✓							SC		
				B <sup>[3]</sup>				✓	✓																
	-91	NORMALLY CLOSED One (1) N.C. auxiliary contact mounted on each contactor or starter	1-6	A					✓	✓			✓	✓											
				B <sup>[3]</sup>				✓	✓																
	-98 <sup>[4]</sup>	NORMALLY OPEN One (1) N.O. auxiliary contact (operates with movement of external handle only)	1-5	A or B	✓	✓	✓	✓	✓	✓	✓	✓	✓	✓	✓	✓	✓	✓	✓	✓	✓	✓		✓	
			6							✓	✓														
	-98X <sup>[6]</sup>	NORMALLY OPEN One (1) N.O. auxiliary contact mounted internally in circuit breaker	1-6	A or B		✓		✓		✓		✓		✓		✓					✓	✓		✓	
	-99 <sup>[4]</sup>	NORMALLY CLOSED One (1) N.C. auxiliary contact (operates with movement of external handle only)	1-5	A or B	✓	✓	✓	✓	✓	✓	✓	✓	✓	✓	✓	✓	✓	✓	✓	✓	✓	✓		✓	
			6							✓	✓														
	-99X <sup>[6]</sup>	NORMALLY CLOSED One (1) N.C. auxiliary contact mounted internally in circuit breaker	1-6	A or B		✓		✓		✓		✓		✓		✓					✓	✓		✓	

[1] For vacuum contactor starters only option -91 or -900111 is allowed.

[2] Multiple auxiliary contacts must be group coded by adding the second and third digit of the special feature number to the base digit "9" (e.g., 90-91-98X-99, when group coded, reads **9018X9**).

[3] Type B auxiliary contacts are wired to terminal blocks. If the number of auxiliary contact wiring points required exceeds the number of terminals available in the unit, remaining auxiliary contacts will be unwired. Refer to wiring diagram.

[4] The maximum number of auxiliary contacts that can be supplied is two (2), in any combination. Contacts actuate with movement of unit handle to ON or OFF position only. Contacts are not designed to actuate as the result of a circuit breaker trip. For such applications, auxiliary contacts mounted internally (98X or 99X) must be selected. Auxiliary contacts are supplied unwired. Not available on dual 2192F units or 1600A and 2000A 2193M units.

[5] For 1600A and 2000A 2192M, the maximum number of auxiliary contacts is four (4). The following contact arrangements are allowed.

- -98, -99, or -989 two contacts, (1) N.O./N.C. Form-C contacts
- -988, -999 four contacts, two (1) N.O./N.C. Form-C contacts

The auxiliary contacts are mounted external to the switch and are actuated by the movement of the operating handle. Auxiliary contacts are supplied unwired.

[6] The maximum number of auxiliary contacts that can be supplied internally is (2) N.O. and (2) N.C. With a shunt trip, the maximum is (1) N.O. and (1) N.C.. Not available for 2193F single or dual mounted when one or both trip codes are '00'.

## Maximum Number of Additional Auxiliary Contacts Per Starter/Contactor

154

Bulletin Number <sup>[1]</sup>	NEMA		
	Size 1-2	Size 3-5	Size 6
2102L, 2103L <sup>[2]</sup>	6	6	—
2112/2113 <sup>[2]</sup>			4
2103L/2113 Dual		—	—
2106/2107	4	4	—
2122/2123			
2102L/2103L/2112/2113 0.5SF	3	—	—
2126/2127	4	—	—

[1] Units selected with OFF pilot light will use one of these contacts. Bulletins 2126 and 2127 will use two of these contacts.

[2] When Bulletin 596 timers are selected on 30-300A contactors or size 1-5 starters, auxiliary mounting positions (P3 and P4) are used, limiting the maximum number of starter auxiliaries to two (2). When 89CB, 89CBL, 89CF, 89P, 700TC, 11DSA2 or 11DSA3 with NEMA Type B wiring is present with transformer control in 1.0 space factor units, the number of starter auxiliary contacts is limited to four (4). When 89CBL is present with separate control and control circuit fuse (21) in 1.0 space factor units, the number of starter auxiliary contacts is limited to four (4) for units with 7FEC\_-. In E3 overloads, the number of starter auxiliary contacts is limited to five (5). For size 2 units with 7FEEE\_ or 7FEE\_D, E1 Plus Overload, the number of auxiliary contacts is limited to five (5).

## Factory-Installed Options, Modifications, Accessories for Contactors and Starters, Metering, Mains and Feeders, Lighting and Power Panels, Transformer and Miscellaneous Units

Multiple option numbers are separated by a dash and added to the base catalog number in ascending order.

155

Option	Option Number	Description	FVC	FVR	FVNR	TS1W TS2W	TSR1W TSR2W	TSR1W TSR2W	Delivery Program	
			2102L 2103L	2106 2107	2112 2113	2122 2123	2126E 2127E 2126F 2127F	2126J 2127J 2126K 2127K		
Omission of Power Terminal Blocks <sup>[1]</sup>	-106	For contactors and starters (NEMA Type BD) NEMA sizes 1, 2 and 3	✓	✓	✓			✓	SC	
	-110 <sup>[2]</sup>	For 30A and 60A fusible disconnect feeders	Available for Bulletin 2192F ONLY							
Control Terminal Block <sup>[1]</sup> <sup>[3],[4]</sup>	-107	One (1) extra 5-pole control terminal block (unwired)	✓	✓	✓	✓	✓	✓	SC	
T-Handle	-111	T-handle latch on unit door	Available on all units except 2191F, 2191M, 2192M, 2193M, 2195, 2193LE and 2193PP <sup>[5]</sup>							
Key-interlock Mounting Provision <sup>[6]</sup>	-201	For circuit breaker or fusible disconnect main or feeder units. Permits customer mounting of Superior or Kirk brand key interlocks on unit operating handle. <sup>[7]</sup>	Available for Bulletins 2192 and 2193 ONLY							
Current Transducers (4-20mA Output)	-700TC1 <sup>[8]</sup>	Ohio Semitronics Model MCT5-005E 85-135V AC, 50/60Hz power (includes current transformer)			✓				PE	
	-700TC2 <sup>[8]</sup>	Crompton Instruments Model 253-TALU-LSHG 120V AC +/-20%, 50/60Hz power (includes current transformer). SC delivery in Canada.			✓					
Current Sensors (4-20mA Output)	-700TC4 <sup>[8]</sup>	N-K Technologies model AT 12-40V DC at sensor (current transformer not needed on sizes 1-3, included on sizes 4-6)			✓				SC	
	-700TC5 <sup>[8]</sup>	Riley Corp., 5-40VDC at sensor (current transformer not needed) model 420, sizes 1-3, all voltages			✓					
		Riley Corp., 5-40VDC at sensor (current transformer not needed) <sup>[9]</sup>			✓					
		Riley Corp., 5-40VDC at sensor (current transformer not needed) <sup>[10]</sup>			✓					

10

[1] Available for NEMA Wiring Type B only. Not available on 0.5 space factor units. Not available on Bulletin 2112 or 2113 size 2 in 1.0 space factor with E3 (option 7FEC\_).

[2] This option is not available on dual mounted 2192F.

[3] A maximum of two (2) 5-pole control terminal blocks only for each side of dual unit.

[4] An additional block of five control terminals can be supplied for customer use, provided the total number of control terminals does not exceed 15 maximum on units with power terminals, 20 maximum on units without power terminals. Check wiring diagram for limitations.

[5] Provided as standard with Bulletin 2193LE and 2193PP.

[6] Mutually exclusive with ground detection lights (option 88\_). Not available on 0.5 space factor units.

[7] For 150A-1200A 2192M and 150A-2000A 2193M units, use Superior key interlock #S105810Y, Type B-4003-1 (bolt flush when withdrawn) or Kirk key interlock #KFL000010. For 1600A and 2000A 2192M units, use Superior key interlock #S105821Y, Type B-06003-1 (bolt extends 0.375" when withdrawn) or Kirk key interlock #KBL003710. **Note: Fusible units should not be used on a tie (double ended) system, due to access to fuses and back feeding.** For these applications, contact your local Rockwell Automation Sales Office.

[8] Transducer/sensor output is unwired. Not available on 0.5 space factor or dual starter units. Not available with E1 Plus O.L. with ground fault/jam protection (option 7FEE\_G). Options 700TC1, 700TC4 and 700TC5 require minimum 1.5 space factors for size 1 and 2 if optional control relay, timer auxiliary relay or 11DSA2/11DSA3 is used. Option 700TC1 requires minimum 2.0 space factors for Bulletin 2113, size 3 when 11DSA2 or 11DSA3 is used. When control circuit transformer primary fusing is selected, the control transformer secondary fuse is mounted in one of the three starter auxiliary contact pockets. Option 700TC2 always requires minimum 1.5 space factors for sizes 1 and 2. Option 700TC2 requires minimum 2.0 space factors for Bulletin 2113, size 3. Unit ammeter options, current transducer and thermistor protection relay options are mutually exclusive. Options 700TC1, 700TC2, 700TC4 and 700TC5 require extra 0.5 space factor for NEMA Size 4 Bulletin 2112 with Class J and HRCII-C fuses. Requires 2.5 space factor for NEMA Size 4 Bulletin 2113 with HMCP circuit breaker (circuit breaker code CA) and E1 Plus overload relay (Option 7FEE\_). Option 700TC5 requires extra 0.5 space factor for NEMA Size 5 Bulletin 2112 with Class J fuses.

[9] Model 420L, size 4 (all voltages) and size 5 at 380V, 415V, 480V and 600V only.

[10] Model 420X, size 5 at 208V and 240V and size 6 (all voltages).

## Factory-Installed Options, Modifications, Accessories for Contactors and Starters, Metering, Mains and Feeders, Lighting and Power Panels, Transformer and Miscellaneous Units

Multiple option numbers are separated by a dash and added to the base catalog number in ascending order.

156

Option	Option Number	Description	FVC	FVR	FVNR	TS1W TS2W	TSR1W TSR2W	TSR1W TSR2W	Delivery Program
			2102L 2103L	2106 2107	2112 2113	2122 2123	2126E 2127E 2126F 2127F	2126J 2127J 2126K 2127K	
Control Circuit Wiring <sup>[1]</sup>	—	Type MTW(TEW) 90° C copper wire, VW1 rated #16 AWG	✓	✓	✓	✓	✓	✓	SC
	-750 <sup>[2]</sup>	Type MTW(TEW) 90° C copper wire, VW1 rated #14 AWG (tinned)	✓	✓	✓	✓	✓	✓	
	-750B <sup>[2]</sup>	#14 AWG tinned, MTW, 90° C copper wire, VW1 rated and tinned power wire, including stab wires, excluding starter power wire jumpers.	✓	✓	✓	✓	✓	✓	
	-750S <sup>[2]</sup>	Type SIS 90° C copper wire #14 AWG (tinned)	✓	✓	✓	✓	✓	✓	SC (+2 days)
Control Circuit Lugs <sup>[1],[2],[3]</sup>	-750RL	Insulated ring lugs for control wires where possible	✓	✓	✓	✓	✓	✓	SC (+2 days)
	-750SL	Insulated spade lugs for control wires where possible	✓	✓	✓	✓	✓	✓	
Control Wire Markers <sup>[1]</sup>	-751D	Adhesive Brady Datab type markers at each end of control wire. Not available in Canada.	✓	✓	✓	✓	✓	✓	SC
	-751HS	Heat shrink type wire marker	✓	✓	✓	✓	✓	✓	SC (+2 days)
	-751S	Sleeve type wire marker	✓	✓	✓	✓	✓	✓	SC
Omission of Circuit Breaker	-752	NEMA size 1 and 2		✓	✓	✓	✓	✓	SC
		NEMA size 3		✓	✓	✓	✓		
		NEMA size 4		✓	✓	✓	✓		
Shunt Trip	-754	For tripping circuit breakers from remote 120 volt, 60 Hz source	Available on all circuit breaker units <sup>[4]</sup>						
100% Rating of Main Disconnect Switch or Circuit Breaker	-755	Provides 100% rating of main switch or circuit breaker. NEMA Type 1 and Type 1 with gasket only, except non-fused 2192M is available in NEMA Type 12. Not available with NEMA Type 3R or Type 4.	Available on 2192M, 600A-2000A <sup>[5]</sup>						PE-II
			Available on 2193M, 600A-2000A ONLY						

- [1] Options for factory wiring of control circuits. Also available for 2100-DPS\_, 2100-C2D, 2100-E2D\_, and 2100-DC\_05XWD units. Also 2192F, 2192M, 2193F, and 2193M units when option -11DSA\_ is selected. 750B only available when unit is fed from the vertical or horizontal power bus. Dedicated auxiliary devices (e.g., fans), device and component internal wiring and wiring that could affect operation or certification(s) (e.g., insulation temperature class, EMC shielding requirements, communication requirements, UL, cUL, CSA, CE) are not included.
- [2] Not available on 0.5 space factor Bulletin 2102L, 2103L, 2112, or 2113 units.
- [3] Examples where insulated lugs CANNOT be used: Bulletin 800F pilot devices, 700CF, size 6 auxiliaries, and disconnect/circuit breaker auxiliaries and where more than one (1) wire per terminal is required.
- [4] Except for R-frame circuit breakers, not available when two (2) N.O. (98X8X), two (2) N.C. (99X9X) or two (2) N.O. and two (2) N.C. (98X8X9X9X) internal contacts are selected for circuit breakers. Not available on 2193PP plug-in panel board with main circuit breaker or 2193LE lighting panels or 2100M- empty units with circuit breaker or 2193F single or dual mounted when one or both trip codes are '00.'
- [5] 600A switch must use 601A, Class L fuse for 100% rating.

10

## Factory-Installed Options, Modifications, Accessories for Contactors and Starters, Metering, Mains and Feeders, Lighting and Power Panels, Transformer and Miscellaneous Units

157

Option	Option Number	Description	FVC	FVR	FVNR	TS1W TS2W	TSR1W TSR2W	TSR1W TSR2W	Delivery Program		
			2102L 2103L	2106 2107	2112 2113	2122 2123	2126E 2127E 2126F 2127F	2126J 2127J 2126K 2127K			
External DeviceNet Connector with 120VAC Receptacle	-767A <sup>[1]</sup>	Door mounted external DeviceNet connection and 120VAC receptacle for connection of computer to DeviceNet without having to open doors. Mounted on door of DeviceNet power supply unit. See page 104.	Available on 2100-DPS_ units only								
DeviceNet Power Supply, Redundant Design	767C	Provides second power supply and anti-backfeed, blocking diodes. Allows seamless transfer of power from primary to secondary power supply in the event of an internal failure of the primary power supply	Available only for 2100-DPS8_ units. See page 104 for unit selection.								
Unwired Pull-Apart Terminal Blocks	-800	Bulletin 1492-EC 5-pole terminal blocks	All mounting tabs on unit bottom plate are turned up for field installed terminal blocks							Available on 2100-NK and 2100-NJ empty unit inserts and 2100D and 2100M empty unit inserts with disconnecting means ONLY  Not available on 2100-NK05 or 2100-NJ05 units.	SC
	-801		All mounting tabs on unit bottom plate are turned up. (1) 5-pole pull-apart terminal block included.								
	-802		All mounting tabs on unit bottom plate are turned up. (2) 5-pole pull-apart terminal blocks included.								
	-803		All mounting tabs on unit bottom plate are turned up. (3) 5-pole pull-apart terminal blocks included.								
	-804		All mounting tabs on unit bottom plate are turned up. (4) 5-pole pull-apart terminal blocks included.								
French Legend Plates	-860F	Legend plates printed in French are available on all pilot devices. Specify 860F when pilot device option is selected.	Available on all pilot devices								
Spanish Legend Plates	-860S	Legend plates printed in Spanish are available on all pilot devices. Specify 860S when pilot device option is selected.	Available on all pilot devices								
Unit Door Nameplates <sup>[2]</sup>	—	Door Nameplate Screws	Plated steel nameplate screws. Provided when cardholder or nameplates are not selected.							Available on all units	SC-II
		Card Holder for Unit Doors	1.125" x 3.625" plastic card holders with blank cards							Available on all units	
		1.125" x 3.625" engraved 3-line or 4-line nameplate	Acrylic plate (available in U.S. only). Lettering is white with black letters or black with white letters.							Available on all units	
			Phenolic plate. Lettering is white with black letters, black with white letters or red with white letters.							Available on all units	
Overload Relay Heater Elements (Bulletin 592)	—	Set of three (3) W-type heater elements per overload supplied loose in each unit. Available on SC-II or PE-II assembled motor control centers only. See 227 for heater element selection instructions.		✓	✓		✓	✓	✓		
Stainless Steel Nameplate Screws	—	Stainless steel nameplate screws for unit nameplates (2 per unit)	Available on all units								
Export Packing Below Deck	—	Container is skid mounted and packaged in clear plastic. Packing is not watertight or waterproof. Considerations should be taken if extended storage is expected.	✓	✓	✓	✓	✓	✓	SC (+2 days)		

10

[1] When specified on 2100-DPS8KXWD, 2100-DPS8K\_ or 2100-DPS8K\_-30\_ DeviceNet Power Supply Unit, the control circuit transformer increases to 500 VA.  
 [2] Blank nameplates will be supplied when no engraving is selected. Letter height for 3-line nameplates will be 0.22". Letter height for 4-line nameplates will be 0.18". All text will be centered horizontally and vertically.



# Factory-Installed Options, Modifications, Accessories for Space Saving NEMA Starter Units

- Multiple option numbers are separated by a dash and added to the base catalog number in ascending order.
- Pilot devices are Bulletin 800F
- To select pilot light lens color, add letter(s) to the option number: A = amber, B = blue, C = clear, G = green, R = red, W = white (e.g., 4RG is a red ON and green OFF pilot light). Clear and white are not available for Bulletin 800T LED type pilot lights. Clear is not available on Bulletin 800F LED pilot lights. White is not available on Bulletin 800F incandescent pilot lights.

158

Option	Description		FVR	FVNR	Option Number	Delivery Program
			2106, 2107	2112, 2113		
Push Buttons <sup>[1], [2]</sup>	START - STOP			✓	-1 <sup>[3]</sup>	
	FORWARD - REVERSE - STOP		✓			
	STOP		✓	✓		
Push Buttons and Selector Switch <sup>[1], [2]</sup>	HAND-START, HAND-STOP, HAND-OFF-AUTO			✓	-1F <sup>[4]</sup>	
Selector Switch <sup>[1], [2]</sup>	HAND - OFF - AUTO			✓	-3	
	FORWARD - OFF - REVERSE <sup>[3]</sup>		✓			
	OFF - ON			✓		
Pilot Lights (Transformer Type for 800T, Full-voltage for 800F) <sup>[2]</sup>	Standard Type Lens color designator A, B, C, G, R	ON		✓	-4_ <sup>[4], [5]</sup>	SC
		ON-OFF		✓	-4_ <sup>[4], [6], [7]</sup>	
		FORWARD-REVERSE	✓		-4_ <sup>[7]</sup>	
		FORWARD-REVERSE-OFF	✓		-4_ <sup>[6], [8]</sup>	
		OVERLOAD	✓	✓	-4T <sup>[9]</sup>	
	LED Type Lens color designator A, B, G, R, W	ON		✓	-4L_ <sup>[4], [5]</sup>	
		ON-OFF		✓	-4L_ <sup>[4], [6], [7]</sup>	
		FORWARD-REVERSE	✓		-4L_ <sup>[7]</sup>	
		FORWARD-REVERSE-OFF	✓		-4L_ <sup>[6], [8]</sup>	
		OVERLOAD	✓	✓	-4TL <sup>[9]</sup>	
	Push-to-Test Standard Type Lens color designator A, B, C, G, R	ON		✓	-5_ <sup>[4], [5]</sup>	
		ON-OFF		✓	-5_ <sup>[4], [6], [7]</sup>	
		FORWARD-REVERSE	✓		-5_ <sup>[7]</sup>	
		FORWARD-REVERSE-OFF	✓		-5_ <sup>[6], [8]</sup>	
		OVERLOAD	✓	✓	-5T <sup>[9]</sup>	
	Push-to-Test LED Type Lens color designator A, B, G, R, W	ON		✓	-5L_ <sup>[4], [5]</sup>	
		ON-OFF		✓	-5L_ <sup>[4], [6], [7]</sup>	
		FORWARD-REVERSE	✓		-5L_ <sup>[7]</sup>	
		FORWARD-REVERSE-OFF	✓		-5L_ <sup>[6], [8]</sup>	
		OVERLOAD	✓	✓	-5TL <sup>[9]</sup>	

11

[1] Push buttons may not be used in conjunction with selector switches, except with option 1F.  
 [2] Maximum of four (4) pilot devices on 0.5 space factor units. When more than four (4) pilot devices are required, the 0.5 space factor units must be increased to 1.0 space factor. Maximum of six (6) pilot devices on 1.0 space factor and larger units.  
 [3] Mutually exclusive with DeviceNet Starter Auxiliary (11DSA\_), E3 solid-state overload relays (7FEC\_) and E1 Plus solid state overload relay 7FEE\_D.  
 [4] When option 1F is used with 11DSA\_ or 7FEE\_D, one (1) N.O. auxiliary contact, option 90, is required. When option 1F is selected with any ON pilot light, one (1) N.O. auxiliary contact, option 90, is required.  
 [5] When used in 2112 or 2113 with DeviceNet Starter Auxiliary (11DSA\_), 7FEE\_D or E3 electronic overload relay (7FEC\_), one (1) N.O. auxiliary contact, option 90, is required. When used in 2112 or 2113 with DeviceNet Starter Auxiliary (11DSA3) and option 1F, 7FEE\_D and option 1F or E3 electronic overload relay (7FEC\_) and option 1F, two (2) N.O. auxiliary contacts, option 900, are required.  
 [6] Select one (1) N.C. auxiliary contact, option 91, for OFF pilot light when in 2106, 2107, 2112 or 2113.  
 [7] When used in 2112 or 2113 with DeviceNet Starter Auxiliary (11DSA3), 7FEE\_D or E3 electronic overload relay (7FEC\_), one (1) N.O. and one (1) N.C. auxiliary contact, option 901, is required. When used in 2112 or 2113 with DeviceNet Starter Auxiliary (11DSA3) and option 1F, 7FEE\_D and option 1F or E3 solid-state overload relay (7FEC\_) and option 1F, two (2) N.O. and one (1) N.C. auxiliary contacts, option 9001, are required. When used in 2106 or 2107 with DeviceNet Starter Auxiliary (11DSA3) or E3 electronic overload relay (7FEC\_), one (1) N.O. auxiliary contact, option 90, is required.  
 [8] When used in 2106 or 2107 with DeviceNet Starter Auxiliary (11DSA3) or E3 electronic overload relay (7FEC\_), one (1) N.O. and one (1) N.C. auxiliary contact, option 901, is required.  
 [9] Not available with DeviceNet Starter Auxiliary (11DSA3), 7FEE\_D or E3 electronic overload relay (7FEC\_).

## Factory-Installed Options, Modifications, Accessories for Space Saving NEMA Starter Units

Multiple option numbers are separated by a dash and added to the base catalog number in ascending order.

159

Option	Option Number	Description	FVR	FVNR	Delivery Program	
			2106, 2107	2112, 2113		
Control Circuit Transformer (with grounded and fused secondary)	-6P	Standard capacity with primary fusing	NEMA Size 1	80 VA <sup>[1]</sup>	80 VA <sup>[1]</sup>	SC
			NEMA Size 2	80 VA	80 VA <sup>[1]</sup>	
	NEMA Size 3-4	250 VA	250 VA			
	NEMA Size 1	130 VA	130 VA			
-6XP <sup>[2]</sup>	Extra capacity with primary fusing	NEMA Size 2	130 VA	130 VA		
		NEMA Size 3-4	350 VA	350 VA		
		NEMA Size 1	130 VA	130 VA		
E1 Plus Electronic Overload Relay <sup>[3],[4]</sup>	-7FEE_ <sup>[5]</sup>	Selectable trip class (10, 15, 20, 30) selectable Auto/Manual-Auto reset electronic overload relay for NEMA starters, size 1-4.	✓	✓ <sup>[6]</sup>		
E1 Plus Electronic Overload Relay with DeviceNet Module <sup>[3],[4],[10]</sup>	-7FEE_D <sup>[5]</sup>	Selectable trip class (10, 20, 30). Selectable Auto/Manual-Auto reset electronic overload relay for starters Size 1-4. Includes DeviceNet module with (2) 24VDC inputs and (1) 110-120VAC output.		✓ <sup>[7]</sup>		
E1 Plus Electronic Overload Relay with Ground Fault Protection Module & Jam Protection <sup>[3],[4]</sup>	-7FEE_G <sup>[5]</sup>	Selectable to class (10, 15, 20, 30) selectable Auto/Manual-Auto reset electronic overload relay for NEMA starters, size 1-3. Includes Ground Fault Protection Module with integral Jam Protection and external Ground Fault Sensor.	NEMA Size 1, 2	✓	✓ <sup>[7]</sup>	
			NEMA Size 3	✓	✓	
			NEMA Size 4		✓ <sup>[8]</sup>	
E1 Plus Electronic Overload Relay with Jam Protection Module <sup>[3],[4]</sup>	7FEE_J <sup>[5]</sup>	Selectable trip class (10, 15, 20, 30) selectable Auto/Manual-Auto reset electronic overload relay for NEMA starters, size 1-4 with Jam Protection Module	✓	✓ <sup>[7]</sup>		
E3 Electronic Overload Relay <sup>[4],[9],[10]</sup> NOTE: For non-DeviceNet applications, a 24VDC separate power source is needed. A Bulletin 193-DNCT DeviceNet Configuration Terminal may be needed for programming and monitoring.	-7FEC1_ <sup>[5]</sup>	E3 Basic overload relay is provided with two (2) 24VDC inputs and one (1) 110-240VAC output	Size 1		✓	
			Size 2		✓	
			Size 3		✓	
			Size 4		✓ <sup>[12]</sup>	
	-7FEC2_ <sup>[5]</sup>	E3 Plus overload relay is provided with four (4) 24VDC inputs and two (2) 110-240VAC outputs	Size 1	✓	✓	
			Size 2	✓	✓	
-7FEC3_ <sup>[5]</sup>		Size 3	✓	✓		
		Size 4		✓ <sup>[12]</sup>		
DeviceNet Starter Auxiliary (DSA) <sup>[10],[11],[12]</sup> (mutually exclusive)	-11DSA2	For use with starters to provide DeviceNet inputs and outputs. Four (4) 120VAC inputs and two (2) 120V outputs. Cannot be selected with E3 electronic overload relay (7FEC_ ) or E1 Plus with DeviceNet (7FEE_D).	✓	✓		
	-11DSA3	For use with starters to provide DeviceNet inputs and outputs. Four (4) 24VDC inputs and two (2) 240VAC max outputs. Cannot be selected with E3 electronic overload relay (7FEC_ ) or E1 Plus with DeviceNet (7FEE_D).	✓	✓		

- [1] For 0.5 space factor or 1.0 space factor with option -15; Bulletin 2106, 2107, 2112 and 2113, the standard capacity VA rating is 75 VA.
- [2] Extra capacity control circuit transformer, option 6XP, changes 0.5 space factor units to 1.0 space factor.
- [3] E1 Plus electronic overload relay is supplied with one (1) N.O. and one (1) N.C. auxiliary contact.
- [4] Overload relay option 7FEE\_, 7FEE\_D, 7FEE\_G, 7FEE\_J or 7FEC\_ must be specified. Overload relay option 7FEE\_, 7FEE\_D, 7FEE\_G, 7FEE\_J and 7FEC\_ are mutually exclusive.
- [5] Option number is not complete.
  - Select overload relay code from appropriate table below and add to option number (e.g., 7FEED or 7FEC2B).
  - For option 7FEC\_ , review configuration options in the table below, and, if needed, select and add to option number (e.g., 7FEC1BY or 7FEC3FYG).
  - NEMA size 1-3 E3 Plus overload relays have ground fault sensor as standard. NEMA size 4-6 E3 Plus overload relays need to have the ground fault configured to include a ground fault sensor. Refer to E3 overload relay configuration options table below.
- [6] 0.5 space factor Size 2, Bulletin 2113 units with pilot devices and external reset button for overload relay are increased to 1.0 space factor.
- [7] 0.5 space factor Size 2, Bulletin 2113 are increased to 1.0 space factor.
- [8] Bulletin 2113, NEMA Size 4 with circuit breaker suffix CA are increased to 1.5 space factors. Bulletin 2113, NEMA Size 4 with circuit breaker suffix CT or CM are increased to 2.0 space factors.
- [9] 0.5 space factor Size 1, Bulletin 2106 and 2107 units are increased to 1.0 space factor. 0.5 space factor Size 1, Bulletin 2112 and 2113 units with pilot devices and external reset button for overload relay are increased to 1.0 space factor. 0.5 space factor Size 2, Bulletin 2113 units are increased to 1.0 space factor.
- [10] Not available with push button or selector switches, except options 3 and 1F. Not available with unwired control relay, option 89CF\_ and 89HA\_.
- [11] 0.5 space factor Size 1, Bulletin 2107 units are increased to 1.0 space factor. 0.5 space factor Size 2, Bulletin 2113 units are increased to 1.0 space factor.
- [12] 1.0 space factor Size 4, Bulletin 2113 units are increased to 1.5 space factor.

### Overload Relay Codes for E1 Plus, Option 7FEE 160

For use with Space Saving NEMA Size	Full Load Current Range (Amperes)	Overload Relay Code, Add to Option Number (e.g., 7FEED)
1	1 - 5	C
	3.2 - 16	D
	5.4 - 27	E
2	9 - 45	F
3	18 - 90	G
4	30 - 150	H

### Overload Relay Codes for E3 and E3 Plus, Option -7FEC\_ 161

For use with Space Saving NEMA Size	Full Load Current Range (Amperes)	Overload Relay Code, Add to Option Number (e.g., 7FEC2B)
1	1 - 5	A
	3 - 15	B
	5 - 25	C
2	9 - 45	D
3	18 - 90	E
4	28 - 140	F

### E3 Overload Relay Configuration Option 162

Description	Overload Relay Code (Add to option number [e.g. 7FEC3FYG])
24VDC input points	None
120VAC input points, available for 110-120VAC control voltage only	Y
Ground fault. Includes Bulletin 193-CBCT3 ground fault sensor	G <sup>[1]</sup>
120VAC input points and ground fault (see description above)	YG <sup>[1]</sup>

[1] Available for Size 4 E3 Plus overload relays only. 1.5 space factor Size 4, Bulletin 2113 units with circuit breaker suffix CT or CM, are increased to 2.0 space factor.

## Factory-Installed Options, Modifications, Accessories for Space Saving NEMA Starter Units

Multiple option numbers are separated by a dash and added to the base catalog number in ascending order.

163

Option	Option Number	Description	FVR	FVNR	Delivery Program	
			2106, 2107	2112, 2113		
Additional Unit Space	-15	Adds 0.5 space factor to the unit after any required space factor increases (due to other options) have been added.	✓	✓		
Surge Suppressor	-17	On starter coil, one per contactor. Selection of this option requires the selection of Option -17R if an optional relay (89__) is also selected.	✓	✓		
	-17R	On control relay, one per control relay. May only be used if optional relay (89__) is selected. Selection of this option requires selection of Option -17.	✓	✓		
Omit Wiring	-19	Omission of control wiring, except primary and secondary transformer wiring	✓	✓		
Control Circuit Fuse	-21	One (1) control circuit fuse for separate control	✓	✓		
Grounded Unit Door	-79GD	Hinge mounted ground strap mounted on bottom hinge of unit door	✓	✓		
Unit Load Connector	-79L	Select on all plug-in units in section with vertical unit load ground bus	Unplated Copper	✓	✓	
	-79LT		Tin Plated Copper	✓	✓	
Unit Ground Stab	-	Copper unit grounds stabs may be used with steel vertical ground bus. Select on plug-in units in sections with vertical plug-in ground bus	Copper Alloy	✓	✓	
	-79U		Unplated Copper	✓	✓	
	-79UT		Tin Plated Copper	✓	✓	
Elapsed Time Meter <sup>[1]</sup>	-85T	Six digit non-resettable meter with tenths, mounted in control station		✓		
Unwired Control Relay <sup>[2] [3] [4] [5]</sup>	-89CF40	Bulletin 700CF 4-pole relay	4 N.O.	2	1	SC
	-89CF31		3 N.O. / 1 N.C.	2	1	
	-89CF22		2 N.O. / 2 N.C.	2	1	
	-89CF40A <sup>[6]</sup>	Bulletin 700CF 4-pole relay with time attachment 0.3 - 30 seconds	4 N.O.	2	1	
	-89CF22A <sup>[6]</sup>		2 N.O. / 2 N.C.	2	1	
	-89CF40B <sup>[6]</sup>	Bulletin 700CF 4-pole relay with time attachment 0.3 - 30 seconds	4 N.O.	2	1	
	-89CF22B <sup>[6]</sup>		2 N.O. / 2 N.C.	2	1	
	-89CF40C <sup>[6]</sup>	Bulletin 700CF 4-pole relay with time attachment 1.8 - 180 seconds	4 N.O.	2	1	
	-89CF22C <sup>[6]</sup>		2 N.O. / 2 N.C.	2	1	
	-89CF40D <sup>[6]</sup>		4 N.O.	2	1	
	-89CF22D <sup>[6]</sup>		2 N.O. / 2 N.C.	2	1	
	-89CF40L <sup>[6]</sup>	Bulletin 700CF 4-pole relay with mechanical latch attachment	4 N.O.	2	1	
	-89CF22L <sup>[6]</sup>		2 N.O. / 2 N.C.	2	1	
	-89HA33 <sup>[6]</sup>	Bulletin 700HA 3PDT relay (Contacts rated 240VAC, max.)	3 N.O. / 3 N.C.	2	1	

11

[1] Elapsed Time Meter (85T) requires one (1) N.O. auxiliary contact, option 90. Mounts in position normally used for two (2) pilot devices, limiting the maximum number of pilot devices allowed.

[2] Not available with E3 electronic overload relays (7FEC) or E1 Plus electronic overload relay with DeviceNet Communications (7FEE\_D).

[3] Requires 0.5 space factor Size 1 Bulletin 2106 and 2107 and size 2 Bulletin 2113 units to be increased to 1.0 space factor.

[4] Requires Size 3 Bulletin 2113 unit to be 1.5 space factor when specified with control circuit transformer (Option 6P or 6XP).

[5] Requires Size 4 Bulletin 2113 unit to be 1.5 space factor when specified with E1 Plus overload relay (Option 7FEE\_) and control circuit transformer (Option 6P or 6XP).

[6] Requires Size 2 Bulletin 2107 unit to be 1.5 space factor when specified with control circuit transformer (Option 6P or 6XP).

## Factory-Installed Options, Modifications, Accessories for Space Saving NEMA Starter Units

Multiple option numbers are separated by a dash and added to the base catalog number in ascending order.

164

Option	Option Number	Description	FVR	FVNR	Delivery Program	
			2106, 2107	2112, 2113		
Auxiliary Contacts <sup>[1]</sup>	-90 <sup>[2]</sup>	NORMALLY OPEN One (1) N.O. auxiliary contact on each contactor or starter	✓	✓	SC	
	-91 <sup>[2]</sup>	NORMALLY CLOSED One (1) N.C. auxiliary contact on each contactor or starter	✓	✓		
	-98 <sup>[3]</sup>	NORMALLY OPEN One (1) N.O. auxiliary contact (operates with movement of external handle only)	✓	✓		
	-98X <sup>[4]</sup>	NORMALLY OPEN, One (1) N.O. auxiliary contact mounted internally in circuit breaker	✓	✓		
	-99 <sup>[3]</sup>	NORMALLY CLOSED, One (1) N.C. auxiliary contact (operates with movement of external handle only)	✓	✓		
	-99X <sup>[4]</sup>	NORMALLY CLOSED, One (1) N.C. auxiliary contact mounted internally in circuit breaker	✓	✓		
T-Handles	-111	T-handle latch on unit door	✓	✓		
Control Wire Markers	-751D	Adhesive Brady Datab type markers at each end of control wire. Not available in Canada	✓	✓		
	-751HS	Heat shrink type wire marker	✓	✓		
	-751S	Sleeve type wire marker	✓	✓		
French Legend Plates	-860F	Legend plates printed in French are available on all pilot devices. Specify 860F when pilot device option is selected.	✓	✓		
Spanish Legend Plates	-860S	Legend plates printed in Spanish are available on all pilot devices. Specify 860S when pilot device option is selected.	✓	✓		
Unit Door Nameplate <sup>[5]</sup>	-	Door Nameplate Screws	Plated steel nameplate screws. Provided when cardholder or nameplates are not selected.	✓	✓	SC-II
	-	Card Holder for Unit Doors	1.125" x 3.625" plastic card holders with blank cards	✓	✓	
	-	1.125" x 3.625" engraved 3-line or 4-line nameplate	Acrylic plate (available in U.S. only), white with black letters or black with white letters	✓	✓	
	-		Phenolic plate, white with black letters, black with white letters or red with white letters	✓	✓	
Stainless Steel Nameplate Screws	-	Stainless steel nameplate screws for unit nameplates (2 per unit)	✓	✓	SC	
Export Packing Below Deck	-	Container is skid mounted and packaged in clear plastic. Packing is not watertight or waterproof. Considerations should be taken if extended storage is expected.	✓	✓	SC (+2 days)	

- [1] Multiple auxiliary contacts must be group coded by adding the second and third digit of the special feature number to the base digit "9" (e.g., 90-91-98X-99, when group coded, reads 9018X9)
- [2] Auxiliary contacts are wired to terminal blocks. If the number of auxiliary contact wiring points exceeds the number of terminals available in the unit, remaining auxiliary contacts will be unwired. See auxiliary contact options table below for allowable auxiliary contact configurations.
- [3] The maximum number of auxiliary contacts that can be supplied is two (2), in any combination. Contacts actuate with movement of unit handle to ON or OFF position only. Contacts are not designed to actuate as the result of a circuit breaker trip. For such applications, auxiliary contacts mounted internally (98X or 99X) must be selected.
- [4] Only available for Bulletin 2107 and 2113. The maximum number of auxiliary contacts that can be supplied internally is two (2) N.O. and two (2) N.C.
- [5] Blank nameplates will be supplied when no engraving is selected or provided. Letter height for 3-line nameplates will be 0.22." Letter height for 4-line nameplates will be 0.18." All text will be centered horizontally and vertically.

### Auxiliary Contact Option

165

Auxiliary Contact Catalog String	Bulletin 2106 and 2112	Bulletin 2107 and 2113	Bulletin 2107	Bulletin 2113	Bulletin 2113
	Size 1	Size 1 and 2	Size 3	Size 3	Size 4
90	✓	✓	✓	✓	✓
91	✓	✓	✓	✓	✓
900	✓	✓	✓	✓	✓
901	✓	✓	✓	✓	✓
911	✓	✓	N/A	✓	✓
9000	✓	✓	N/A	✓	✓
9001	✓	✓	N/A	✓	✓
9011	✓	✓	N/A	✓	✓
9111	✓	✓	N/A	N/A	N/A
90000	✓	✓	N/A	✓	✓
90001	✓	✓	N/A	✓	✓
90011	✓	✓	N/A	✓	✓
90111	✓	✓	N/A	N/A	N/A
91111	✓	✓	N/A	N/A	N/A

# Combination Soft Starter (SMC) Units

## Bulletin 2154H and 2155H

### Soft Starter (SMC) Units - SMC-3 ..... 130

These combination soft starter units are designed especially for use in CENTERLINE motor control centers. Each unit contains a microprocessor-controlled motor controller, control circuit transformer and either a fusible disconnect switch or circuit breaker.

Features include:

- Three starting modes: soft start, kick start and current limit
- Electronic overload protection with selectable overload trip class
- Motor and system diagnostics
- Configurable auxiliary contacts
- Soft stop
- Integrated bypass contactor

Each unit is provided as a NEMA Class 1, Type B unit with terminal blocks mounted within the controller unit for connection of remote pilot devices, input signals, etc. Bulletins 2154H and 2155H are available in NEMA Type 1, NEMA Type 1 with gasket and NEMA Type 12 plug-in construction. Class J time delay fuses provide branch circuit protection on Bulletin 2154H units. Instantaneous or a variety of inverse time (thermal magnetic) circuit breakers provide branch circuit protection on 2155H units. A variety of options such as isolation contactors, auxiliary contacts, pilot devices, protective modules, DeviceNet Starter Auxiliary (DSA), etc., can be added to Bulletin 2154H and 2155H units. Extra space may be required to accommodate the optional equipment.

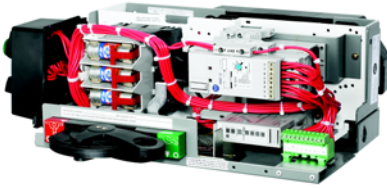

## Bulletin 2154J and 2155J

### Soft Starter (SMC) Units - SMC-Flex ..... 133

These combination soft starter units are designed especially for use in CENTERLINE motor control centers. Each unit contains a microprocessor-controlled motor controller, control circuit transformer and either a fusible disconnect switch or circuit breaker.

Features include:

- Seven standard modes of operation: soft start, current limit start, dual ramp, full voltage, linear speed acceleration, preset slow speed and soft stop
- Optional modes of operation: pump control, Smart Motor Braking™, Accu-Stop™ and slow speed with braking
- Integral SCR bypass
- Electronic overload protection with selectable trip class
- Full metering and diagnostics
- Four programmable auxiliary contacts
- DPI communication
- LCD display
- Keyboard programming

Each unit is provided as a NEMA Class 1, Type B unit with terminal blocks mounted within the controller unit for connection of remote pilot devices, input signals, etc. Bulletins 2154J and 2155J are available in NEMA Type 1, NEMA Type 1 with gasket and NEMA Type 12 construction. Each unit door includes a window for viewing the LCD display, except when door mounted human interface is provided. Class J time delay fuses provide branch circuit protection on 5A-361A Bulletin 2154J units. Class L time delay fuses provide branch circuit protection on 480A Bulletin 2154J units. Instantaneous or varieties of inverse time (thermal magnetic) circuit breakers provide branch circuit protection on 2155J units. A variety of options such as isolation contactors, auxiliary contacts, pilot devices, protective modules, human interface modules, DeviceNet communication etc. can be added to Bulletin 2154J and 2155J units. In some cases, extra space may be required to accommodate the optional equipment.

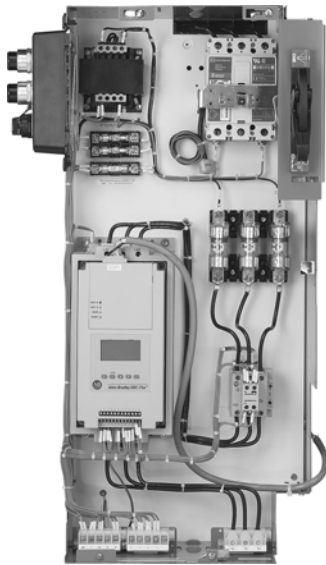

## Combination Soft Starter (SMC) Units

### Catalog Number Explanation - Bulletin 2154H and 2155H

#### Combination Soft Starter (SMC-3) Unit

- Bulletin 150 SMC-3 Solid State Controller
- Three starting modes: soft start, kick start and current limit
- 3A - 135A rating
- Built-in bypass contactor and overload relay
- NEMA Class I, Type B wiring with terminals mounted in the unit

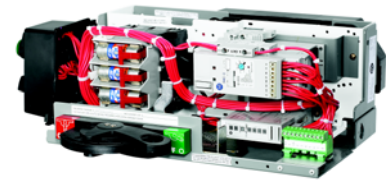

169

<b>2154H</b>	<b>B</b>	-	<b>A</b>	<b>A</b>	<b>B</b>	-	<b>38</b>	-	<b>**</b>
<b>2155H</b>	<b>B</b>	-	<b>A</b>	<b>A</b>	<b>B</b>	-	<b>38CA</b>	-	<b>**</b>
<i>Bulletin Number</i>	<i>Wiring Type</i>		<i>Current Rating</i>	<i>NEMA Enclosure Type</i>	<i>Line Voltage</i>		<i>Horsepower/kW Code and Disconnecting Means</i>		<i>Options</i>

169A

Code	Type
2154H	SMC-3 Soft Starter (SMC) with Fusible Disconnect
2155H	SMC-3 Soft Starter (SMC) with Circuit Breaker

169B

Code	Wiring Type
B	Type B

169C

Code	Current Rating
A	3A
B	9A
D	19A
E	25A
F	30A
G	37A
H	43A
J	60A
K	85A
L	108A
M	135A

169D

Code	NEMA Enclosure Type
A	NEMA Type 1 or Type 1 with gasket with external reset button
K	NEMA Type 1 or Type 1 with gasket without external reset button
D	NEMA Type 12 with external reset button
J	NEMA Type 12 without external reset button

169E

Code	Line Voltage
P	220 - 230V <sup>[1]</sup>
A	240V
N	380V <sup>[1]</sup>
KN	400V <sup>[1]</sup>
I	415V <sup>[1]</sup>
B	480V
C	600V

[1] Units at these voltages are not UL or cUL listed.

169G

Code	Options
	See Options section beginning on Page 137.

169F

Code	Horsepower/kW Code and Disconnecting Means
2154H- "38"	"38" Horsepower/kW code See tables on Page 206
2155H- "38CA"	"38__" Horsepower/kW code "__CA" Circuit Breaker Type See tables on page 206 and 212

Combination Soft Starter Motor Controller with Fusible Disconnect Switch (SMC-3)

- See page 129 for product description.
- Unit includes power fuses.
- Isolation contactor is optional. Select on page 141. This addition or other options may require additional space, see table below.
- Control circuit transformer included.
- Bulletin 150 SMC-3 controller includes (1) N.O. auxiliary contact set to NORMAL. The Bulletin 150-CF64 fan also is included for 3-37A ratings. Integrated fan is standard for 43-135A ratings.
- Bulletin 150 SMC-3 controllers are cUL US (UL and cUL listed) as motor overload protective devices. An external overload relay is not required for single motor applications.
- See page 237 for short circuit withstand ratings.

170

Rating (Amps)	Nominal Horsepower (Nominal kW) The horsepower and kW ratings shown are nominal. The limiting factor in the application and use of the SMC-3 is the output ampere rating.					Disc. Rating	NEMA Type 1 and Type 1 w/ gasket		NEMA Type 12		Delivery Program
	220-230V <sup>[1]</sup>	240V	380V-415V <sup>[1]</sup>	480V	600V <sup>[2]</sup>		Space Factor <sup>[3]</sup>	Catalog Number <sup>[4]</sup> Wiring Type B—Class I	Space Factor <sup>[3]</sup>	Catalog Number <sup>[4]</sup> Wiring Type B—Class I	
	3	(0.25-0.55)	0.5	(0.37-1.1)	0.5-1.5		0.75-2	30	0.5 <sup>[5]</sup>	2154HB-AA_ _	
9	(0.75-2.2)	0.75-2	(1.5-3.7)	2-5	3-7.5	30	0.5 <sup>[5]</sup>	2154HB-BA_ _	0.5 <sup>[5]</sup>	2154HB-BD_ _	
19	(3.7)	3-5	(5.5-7.5)	7.5-10	10-15	30	0.5 <sup>[5]</sup>	2154HB-DA_ _	0.5 <sup>[5]</sup>	2154HB-DD_ _	
25	(5.5)	7.5	(11)	15	20	30	1.0	2154HB-EA_ _	1.0	2154HB-ED_ _	
30	(7.5)	10	(15)	20	25	60	1.0	2154HB-FA_ _	1.0	2154HB-FD_ _	
37	—	—	(18.5)	25	30	60	1.0	2154HB-GA_ _	1.0	2154HB-GD_ _	
43	(11)	15	(22)	30	40	60	1.5	2154HB-HA_ _	2.0	2154HB-HD_ _	
60	(15)	20	(30)	40	50	100	1.5	2154HB-JA_ _	2.5	2154HB-JD_ _	
85	(18.5-22)	25-30	(37)	50	—	100		2154HB-KA_ _		2154HB-KD_ _	
	—	—	(45)	60	60-75	200	3.5	2154HB-LA_ _	4.0	2154HB-LD_ _	
108	(30)	40	(55)	75	100	200		2154HB-MA_ _		2154HB-MD_ _	
135	(37)	50	—	100	125	200					

[1] Units at these voltages are not UL or cUL listed.

[2] Delivery program is PE in U.S. and SC in Canada.

[3] See space factor tables below for NEMA Type 12 or for any NEMA Type when options are selected.

[4] The catalog numbers listed are not complete:

- Select the control voltage code from table on page 205 to identify the preferred control voltage (e.g., 2154HB-AAB).
- If horsepower rated, select the number from table on page 206 that corresponds to the nominal horsepower desired (e.g., 2154HB-AAB-35).
- If kW rated, select the number from table on page 206 that corresponds to the nominal kW desired (e.g., 2154HB-AAN-35K).
- The catalog numbers listed include an external reset button for the SMC-3. To order catalog numbers without the external reset button, replace the letter "A" with the letter "K" (e.g., 2154HB-AK\_ \_) or replace the letter "D" with the letter "J" (e.g., 2154HB-AJ\_ \_).

[5] These units have horizontal operating handles, Bulletin 194R fused molded case switch, up to four Bulletin 800F pilot devices and one 10 pt. pull-apart control terminal block (Type B-D only), with #16 AWG control wire only.

Bulletin 2154H Space Factors with Unit Options

171

Ratings (Amps)	NEMA Type 1 and 1 with Gasket					
	Standard Unit	With Option 13DSA_	With Option 13IC	With Option 89CF	With Option 13IC and 13DSA_	With Option 13IC and 89CF
3 - 19	0.5 <sup>[1]</sup>	0.5 <sup>[1]</sup>	0.5 <sup>[1]</sup>	0.5 <sup>[1],[2]</sup>	1.5	1.5
25 - 37	1.0	1.0	1.0	1.0		
43	1.5	1.5	1.5	1.5		
60						
85	1.5 <sup>[3]</sup>	1.5 <sup>[3]</sup>	1.5 <sup>[3]</sup>	1.5 <sup>[3]</sup>	2.0	2.0
108 - 135	3.5					

[1] 1.0 space factor when -750, -750B, or -750S is selected.

[2] 1.0 space factor when -89CF\_A, -89CF\_B, -89CF\_C, -89CF\_D or -89CF\_L specified.

[3] 2.0 space factor for 45kw at 380V-415V, 60HP at 480V and 60-75HP at 600V applications.

172

Ratings (Amps)	NEMA Type 12					
	Standard Unit	With Option 13DSA_	With Option 13IC	With Option 89CF	With Option 13IC and 13DSA_	With Option 13IC and 89CF
3 - 19	0.5 <sup>[1]</sup>	0.5 <sup>[1]</sup>	1.0	1.0	1.5	1.5
25 - 37	1.0	1.0				
43	2.0	2.0	2.0	2.0	2.0	2.0
60	2.5	2.5	2.5	2.5	2.5	2.5
85			3.0		3.0	3.0
108 - 135	4.0					

[1] 1.0 space factor when -750, -750B, or -750S is selected.

## Combination Soft Starter (SMC) Units

### Units—2155H

#### Combination Soft Starter Motor Controller with Circuit Breaker (SMC-3)

- See page 129 for product description.
- Isolation contactor is optional. Select on page 141. This addition or other options may require additional space.
- Control circuit transformer included.
- Bulletin 150 SMC-3 controller includes (1) N.O. auxiliary contact set to NORMAL. The Bulletin 150-CF64 fan also is included for 3-37A ratings. Integrated fan is standard for 43-135A ratings.
- Bulletin 150 SMC-3 controllers are cUL US (UL and cUL listed) as motor overload protective devices. An external overload relay is not required for single motor applications.
- See page 237 for short circuit withstand ratings.

173

Rating (Amperes)	Nominal Horsepower (Nominal kW) The horsepower and kW ratings shown are nominal. The limiting factor in the application and use of the SMC-3 is the output ampere rating.					NEMA Type 1 and Type 1 with gasket		NEMA Type 12		Delivery Program
	220 - 230V [1]	240V	380V-415V [1]	480V	600V [2]	Space Factor	Catalog Number [3] Wiring Type B - Class I	Space Factor	Catalog Number [3] Wiring Type B - Class I	
3	(0.25-0.55)	0.5	(0.37-1.1)	0.5-1.5	0.75-2	1.0	2155HB-AA_ _	1.0	2155HB-AD_ _	SC
9	(0.75-2.2)	0.75-2	(1.5-3.7)	2-5	3-7.5		2155HB-BA_ _		2155HB-BD_ _	
19	(3.7)	3-5	(5.5-7.5)	7.5-10	10-15		2155HB-DA_ _		2155HB-DD_ _	
25	(5.5)	7.5	(11)	15	20		2155HB-EA_ _		2155HB-ED_ _	
30	(7.5)	10	(15)	20	25		2155HB-FA_ _		2155HB-FD_ _	
37	—	—	(18.5)	25	30		2155HB-GA_ _		2155HB-GD_ _	
43	(11)	15	(22)	30	40	1.5	2155HB-HA_ _	2155HB-HD_ _		
60	(15)	20	(30)	40	50		2155HB-JA_ _	2155HB-JD_ _		
85	(18.5-22)	25-30	(37)	50	—	3.0 <sup>[4]</sup>	2155HB-KA_ _	2155HB-KD_ _		
	—	—	(45)	60	60-75					
108	(30)	40	(55)	75	100	2.5	2155HB-LA_ _	3.5	2155HB-LD_ _	
135	(37)	50	—	100	—	2.5	2155HB-MA_ _		2155HB-MD_ _	
135	—	—	—	125	—	3.0				

[1] Units at these voltages are not UL listed or CSA certified.

[2] Delivery program is PE in the United States and SC in Canada.

[3] The catalog numbers listed are not complete:

- Select the control voltage code from the table on page 205 to identify the preferred control voltage (e.g. 2155HB-AAB)
- If horsepower rated, select the number from the table on page 206 that corresponds to the nominal horsepower desired (e.g. 2155HB-AAB-35)
- If kW rated, select the number from the table on page 206 that corresponds to the nominal kW desired (e.g. 2155HB-AAN-35K)
- Select the appropriate suffix from the table on page 212 to identify the circuit breaker type (e.g. 2155HB-AAB-35CA or 2155HB-AAN-35KCA)
- The catalog numbers listed include an external reset button for the SMC-3. To order catalog numbers without the external reset button, replace the letter "A" with the letter "K" (e.g. 2155HB-AK\_ \_) or replace the letter "D" with the letter "J" (e.g. 2155HB-AJ\_ \_).

[4] Reduce by 0.5 space factor for 45kW at 380V-415V, 60HP at 480V and 60-75HP at 600V applications when circuit breaker suffix CT or CM is selected.

#### Bulletin 2155H Space Factors with Unit Options

174

Ratings (Amps)	NEMA Type 1 and 1 with Gasket												
	Standard Unit	With Option 13DSA	With Option 13HIC	With Option 13IC	With Option 89CF	With Option 13IC and 13DSA	With Option 13IC and 89CF	With Option 13HIC and 13DSA	With Option 13HIC and 13IC	With Option 13HIC and 89CF	With Option 13HIC and 13IC and 13DSA	With Option 13HIC and 13IC and 89CF	
3 - 37	1.0	1.0	1.5	1.0	1.0	1.0	1.0	1.5	1.5	1.5	1.5	1.5	
43	1.5	1.5		1.5	1.5	1.5	1.5						1.5
60				1.5 <sup>[1]</sup>	1.5 <sup>[1]</sup>		1.5 <sup>[1]</sup>						1.5 <sup>[1]</sup>
85													
108-135 <sup>[2]</sup>	2.5		3.5			2.5					3.5		
108-135 <sup>[3]</sup>	3.0		4.0			3.0					4.0		

[1] 2.0 space factor for 45 kw at 380V-415V, 60HP at 480V and 60-75HP at 600V applications, when used with circuit breaker types CT or CM.

[2] Space factor when circuit breaker suffix 'CA' is selected; except for 125HP at 600V.

[3] Space factor when circuit breaker suffix 'CT' or 'CM' is selected, or when circuit breaker suffix 'CA' is selected for 125HP at 600V.

175

Ratings (Amps)	NEMA Type 12											
	Standard Unit	With Option 13DSA	With Option 13HIC	With Option 13IC	With Option 89CF	With Option 13IC and 13DSA	With Option 13IC and 89CF	With Option 13HIC and 13DSA	With Option 13HIC and 13IC	With Option 13HIC and 89CF	With Option 13HIC and 13IC and 13DSA	With Option 13HIC and 13IC and 89CF
3 - 37	1.0	1.0	1.5	1.0	1.0	1.0	1.0	1.5	1.5	1.5	1.5	1.5
43	2.0	2.0	2.5	2.0	2.0	2.0	2.0	2.5	2.5	2.5	2.5	2.5
60	2.5	2.5	3.0	2.5	2.5	2.5	2.5	3.0	3.0	3.0	3.0	3.0
85	3.0 <sup>[1]</sup>	3.0 <sup>[1]</sup>	3.5 <sup>[1]</sup>	3.5 <sup>[1]</sup>	3.0 <sup>[1]</sup>	3.5 <sup>[1]</sup>	3.5 <sup>[1]</sup>	3.5 <sup>[1]</sup>	4.0 <sup>[1]</sup>	3.5 <sup>[1]</sup>	4.0 <sup>[1]</sup>	4.0 <sup>[1]</sup>
108-135 <sup>[2]</sup>	3.5		4.0			3.5					4.0	
108-135 <sup>[3]</sup>	3.5		4.5			3.5					4.5	

[1] Reduce by 0.5 space factor for 45kW at 380V-415V, 60HP at 480V and 60-75HP at 600V applications when circuit breaker suffix CT or CM is selected.

[2] Space factor when circuit breaker suffix 'CA' is selected; except for 125HP at 600V.

[3] Space factor when circuit breaker 'CT' or 'CM' is selected, or when circuit breaker suffix 'CA' is selected for 125HP at 600V.

## Catalog Number Explanation - Bulletin 2154J and 2155J Combination Soft Starter (SMC-Flex) Unit

- Seven standard modes of operation: soft stop, current limit, dual ramp, full-voltage, linear speed acceleration, preset slow speed and soft stop
- Optional modes of operation: pump control, Smart Motor Braking™, Accu-Stop™ and slow speed with braking
- 5 - 480A rating
- Built-in bypass contactor and overload relay
- NEMA Class I, Type B wiring with terminals mounted in unit

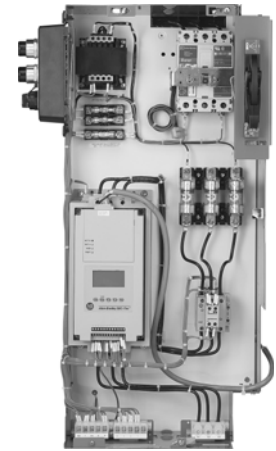

176

<b>2154J</b>		<b>B</b>	-	<b>F108</b>	<b>L</b>	<b>K</b>	<b>B</b>	-	<b>49</b>	-	<b>**</b>																																																						
<b>2155J</b>		<b>B</b>	-	<b>F108</b>	<b>L</b>	<b>K</b>	<b>B</b>	-	<b>49CA</b>	-	<b>**</b>																																																						
Bulletin Number	Wiring Type	Current Rating		NEMA Type	Line Voltage	Horsepower/kW Code and Disconnecting Means		Options																																																									
<p>176A</p> <table border="1"> <thead> <tr> <th>Code</th> <th>Type</th> </tr> </thead> <tbody> <tr> <td>2154J</td> <td>SMC-Flex Soft Starter (SMC) with Fusible Disconnect</td> </tr> <tr> <td>2155J</td> <td>SMC-Flex Soft Starter (SMC) with Circuit Breaker</td> </tr> </tbody> </table>		Code	Type	2154J	SMC-Flex Soft Starter (SMC) with Fusible Disconnect	2155J	SMC-Flex Soft Starter (SMC) with Circuit Breaker	<p>176C</p> <table border="1"> <thead> <tr> <th>Code</th> <th>Current Rating</th> </tr> </thead> <tbody> <tr><td>F005</td><td>5A</td></tr> <tr><td>F025</td><td>25A</td></tr> <tr><td>F043</td><td>43A</td></tr> <tr><td>F060</td><td>60A</td></tr> <tr><td>F085</td><td>85A</td></tr> <tr><td>F108</td><td>108A</td></tr> <tr><td>F135</td><td>135A</td></tr> <tr><td>F201</td><td>201A</td></tr> <tr><td>F251</td><td>251A</td></tr> <tr><td>F317</td><td>317A</td></tr> <tr><td>F361</td><td>361A</td></tr> <tr><td>F480</td><td>480A</td></tr> </tbody> </table>		Code	Current Rating	F005	5A	F025	25A	F043	43A	F060	60A	F085	85A	F108	108A	F135	135A	F201	201A	F251	251A	F317	317A	F361	361A	F480	480A	<p>176D</p> <table border="1"> <thead> <tr> <th>Code</th> <th>Line</th> </tr> </thead> <tbody> <tr> <td>L</td> <td>Connected</td> </tr> </tbody> </table>		Code	Line	L	Connected	<p>176F</p> <table border="1"> <thead> <tr> <th>Code</th> <th>Line Voltage</th> </tr> </thead> <tbody> <tr><td>P</td><td>220 - 230V<sup>[1]</sup></td></tr> <tr><td>A</td><td>240V</td></tr> <tr><td>N</td><td>380V<sup>[1]</sup></td></tr> <tr><td>KN</td><td>400V<sup>[1]</sup></td></tr> <tr><td>I</td><td>415V<sup>[1]</sup></td></tr> <tr><td>B</td><td>480V</td></tr> <tr><td>C</td><td>600V</td></tr> </tbody> </table> <p>[1] Units at these voltages are not UL or cUL listed.</p>		Code	Line Voltage	P	220 - 230V <sup>[1]</sup>	A	240V	N	380V <sup>[1]</sup>	KN	400V <sup>[1]</sup>	I	415V <sup>[1]</sup>	B	480V	C	600V	<p>176H</p> <table border="1"> <thead> <tr> <th>Code</th> <th>Options</th> </tr> </thead> <tbody> <tr> <td></td> <td>See Options section beginning on Page 137.</td> </tr> </tbody> </table>		Code	Options		See Options section beginning on Page 137.
Code	Type																																																																
2154J	SMC-Flex Soft Starter (SMC) with Fusible Disconnect																																																																
2155J	SMC-Flex Soft Starter (SMC) with Circuit Breaker																																																																
Code	Current Rating																																																																
F005	5A																																																																
F025	25A																																																																
F043	43A																																																																
F060	60A																																																																
F085	85A																																																																
F108	108A																																																																
F135	135A																																																																
F201	201A																																																																
F251	251A																																																																
F317	317A																																																																
F361	361A																																																																
F480	480A																																																																
Code	Line																																																																
L	Connected																																																																
Code	Line Voltage																																																																
P	220 - 230V <sup>[1]</sup>																																																																
A	240V																																																																
N	380V <sup>[1]</sup>																																																																
KN	400V <sup>[1]</sup>																																																																
I	415V <sup>[1]</sup>																																																																
B	480V																																																																
C	600V																																																																
Code	Options																																																																
	See Options section beginning on Page 137.																																																																
<p>176B</p> <table border="1"> <thead> <tr> <th>Code</th> <th>Wiring Type</th> </tr> </thead> <tbody> <tr> <td>B</td> <td>Type B</td> </tr> </tbody> </table>		Code	Wiring Type	B	Type B	<p>176E</p> <table border="1"> <thead> <tr> <th>Code</th> <th>NEMA Enclosure Type</th> </tr> </thead> <tbody> <tr> <td>K</td> <td>NEMA Type 1 or Type 1 with gasket without external reset button</td> </tr> <tr> <td>J</td> <td>NEMA Type 12 without external reset button</td> </tr> </tbody> </table>		Code	NEMA Enclosure Type	K	NEMA Type 1 or Type 1 with gasket without external reset button	J	NEMA Type 12 without external reset button	<p>176G</p> <table border="1"> <thead> <tr> <th>Code</th> <th>Horsepower/kW Code and Disconnecting Means</th> </tr> </thead> <tbody> <tr> <td>2154J-"49"</td> <td>"49" Horsepower/kW code" See table on Page 206</td> </tr> <tr> <td>2155J- "49CA"</td> <td>"49__" Horsepower/kW code " __CA" Circuit Breaker Type See tables on page 206 and 212</td> </tr> </tbody> </table>		Code	Horsepower/kW Code and Disconnecting Means	2154J-"49"	"49" Horsepower/kW code" See table on Page 206	2155J- "49CA"	"49__" Horsepower/kW code " __CA" Circuit Breaker Type See tables on page 206 and 212																																												
Code	Wiring Type																																																																
B	Type B																																																																
Code	NEMA Enclosure Type																																																																
K	NEMA Type 1 or Type 1 with gasket without external reset button																																																																
J	NEMA Type 12 without external reset button																																																																
Code	Horsepower/kW Code and Disconnecting Means																																																																
2154J-"49"	"49" Horsepower/kW code" See table on Page 206																																																																
2155J- "49CA"	"49__" Horsepower/kW code " __CA" Circuit Breaker Type See tables on page 206 and 212																																																																

12

## Combination Soft Starter (SMC) Units

### Units—2154J

#### Combination Soft Starter Motor Controller with Fusible Disconnect Switch (SMC-Flex) - Line Connected

- See page 129 for product description.
- SMC-Flex units are configured as line connected, for Delta connected contact factory.
- Isolation contactor is optional. Select on page 141. The addition of this option may require additional space. See the table below, for space factor of units with option.
- Unit includes power fuses.
- Control circuit transformer included.
- Bulletin 150 SMC-Flex controllers are C-UL US (UL and C-UL listed) as motor overload protective devices. An external overload relay is not required for single motor applications.
- See page 237 for short circuit withstand ratings.

177

Rating (Amps)	Nominal Horsepower (Nominal kW) The horsepower and kW ratings shown are nominal. The limiting factor in the application and use of the SMC-Flex is the output ampere rating.					Disc. Rating	NEMA Type 1 and Type 1 w/ gasket		NEMA Type 12		Delivery Program
	220-230V [1]	240V	380V-415V [1]	480V	600V [2]		Space Factor	Catalog Number [3] Wiring Type B— Class It	Space Factor	Catalog Number [3] Wiring Type B— Class I	
5	(0.25-1.1)	0.5-1	(0.37-2.2)	0.5-3	0.75-3	30	2.0	2154JB-F005LK_ -__	3.0	2154JB-F005LJ_ -__	SC
25	(1.5-5.5)	1.5-7.5	(3.7-11)	5-15	5-20	30		2154JB-F025LK_ -__		2154JB-F025LJ_ -__	
43	(7.5-11)	10-15	(15-22)	20-30	25-40	60	2154JB-F043LK_ -__	2154JB-F043LJ_ -__			
60	(15)	20	(30)	40	50	100	2154JB-F060LK_ -__	2154JB-F060LJ_ -__			
85	(18.5-22)	25-30	(37)	50	—	100	2.5	2154JB-F085LK_ -__	3.5	2154JB-F085LJ_ -__	
	—	—	(45)	60	60-75	200					
108	(30)	40	(55)	75	100	200	3.5	2154JB-F108LK_ -__	4.0	2154JB-F108LJ_ -__	
135	(37)	50	—	100	125	200		2154JB-F135LK_ -__		2154JB-F135LJ_ -__	
201	(45-55)	60-75	(75-90)	125-150	150-200	400	6.0 <sup>[4]</sup> , 20" W	2154JB-F201LK_ -__	6.0 <sup>[4]</sup> , 20" W	2154JB-F201LJ_ -__	SC-II
251	(75)	100	(110-132)	200	250	400		2154JB-F251LK_ -__		2154JB-F251LJ_ -__	
317	(90)	125	(150-160)	250	300	400	6.0 <sup>[5]</sup> , 20" W, 20" D	2154JB-F317LK_ -__	6.0 <sup>[5]</sup> , 20" W, 20" D	2154JB-F317LJ_ -__	
361	(110)	150	(185)	300	350	600		2154JB-F361LK_ -__		2154JB-F361LJ_ -__	
480	(132)	200	(200-250)	350-400	400-500	600		2154JB-F480LK_ -__		2154JB-F480LJ_ -__	

[1] Units at these voltages are not UL listed or CSA certified.

[2] Delivery program is PE-II in the United States and SC-II in Canada.

[3] The catalog numbers listed are not complete:

- Select the control voltage code from table on page 205 to identify the preferred control voltage (e.g., 2154JB-F108LKB).
- If horsepower rated, select the number from table on page 206 that corresponds to the nominal horsepower desired, (e.g., 2154JB-F108LKB-49).
- If kW rated, select the number from table on page 206 that corresponds to the nominal kW desired, (e.g., 2154JB-F108LKN-49K).

[4] Frame mounted unit, section does not have vertical wireway. The design of these units is optimized for bottom entry of load cables. For top entry of load cables, consult the factory.

[5] Frame mounted unit, section does not have vertical wireway. Horizontal bus is 5" deeper than standard. The design of these units is optimized for bottom entry of load cables. For top entry of load cables, consult the factory.

#### Bulletin 2154J Space Factors with Unit Options

178

Rating (Amperes)	Space Factor for NEMA Type 1 and Type 1 w/ gasket Units				Space Factor for NEMA Type 12 Units			
	Standard Unit	With Option 13GF	With Option 13IC	With Options 13GF and 13IC	Standard Unit	With Option 13GF	With Option 13IC	With Options 13GF and 13IC
5	2.0				3.0			
25								
43								
60	2.5				3.0 / 3.5 <sup>[1]</sup>			
85								
108	3.5				4.0			
135								
201	6.0, 20" W				6.0, 20" W			
251								
317	6.0, 20" W, 20" D		6.0, 25" W, 20" D		6.0, 20" W, 20" D		6.0, 25" W, 20" D	
361	6.0, 20" W, 20" D		6.0, 25" W, 20" D		6.0, 20" W, 20" D		6.0, 25" W, 20" D	
480	6.0, 20" W, 20" D		6.0, 30" W, 20" D		6.0, 20" W, 20" D		6.0, 30" W, 20" D	

[1] Requires 3.5 space factor for 45kW @ 380-415V, 60HP @ 480V and 60-75HP @ 600V.

Combination Soft Starter Motor Controller with Circuit Breaker (SMC-Flex) - Line Connected

- See page 129 for product description.
- SMC-Flex units are configured as line connected, for Delta connected contact factory.
- Isolation contactor is optional. Select on page 141. The addition of this option may require additional space. See page 135 for space factor of units with option.
- Control circuit transformer included.
- Bulletin 150 SMC-Flex controllers are C-UL US (UL and C-UL listed) as motor overload protective devices. An external overload relay is not required for single motor applications.
- See page 237 for short circuit withstand ratings.

179

Rating (Amps)	Nominal Horsepower (Nominal kW) The horsepower and kW ratings shown are nominal. The limiting factor in the application and use of the SMC-Flex is the output ampere rating.					NEMA Type 1 and Type 1 w/ gasket		NEMA Type 12		Delivery Program
	220-230V [1]	240V	380V-415V [1]	480V	600V [2]	Space Factor	Catalog Number [3] Wiring Type B—Class I	Space Factor	Catalog Number [3] Wiring Type B—Class I	
5	(0.25-1.1)	0.5-1	(0.37-2.2)	0.5-3	0.75-3	2.0	2155JB-F005LK_ _ _	3.0	2155JB-F005LJ_ _ _	SC
25	(1.5-5.5)	1.5-7.5	(3.7-11)	5-15	5-20		2155JB-F025LK_ _ _		2155JB-F025LJ_ _ _	
43	(7.5-11)	10-15	(15-22)	20-30	25-40		2155JB-F043LK_ _ _		2155JB-F043LJ_ _ _	
60	(15)	20	(30)	40	50		2155JB-F060LK_ _ _		2155JB-F060LJ_ _ _	
85	(18.5-22)	25-30	(37)	50-60	60-75	2.5	2155JB-F085LK_ _ _	3.0 <sup>[4]</sup>	2155JB-F085LJ_ _ _	
	—	—	(45)	—	—		2155JB-F108LK_ _ _	3.5	2155JB-F108LJ_ _ _	
108	(30)	40	(55)	75	100	2155JB-F135LK_ _ _	2155JB-F135LJ_ _ _			
135	(37)	50	—	100	125	6.0 <sup>[5]</sup> , 20" W	2155JB-F201LK_ _ _	6.0 <sup>[5]</sup> , 20" W	2155JB-F201LJ_ _ _	
201	(45-55)	60-75	(75-90)	125-150	150-200		2155JB-F251LK_ _ _		2155JB-F251LJ_ _ _	
251	(75)	100	(110-132)	200	250		2155JB-F317LK_ _ _		2155JB-F317LJ_ _ _	
317	(90)	125	(150-160)	250	300		2155JB-F361LK_ _ _		2155JB-F361LJ_ _ _	
361	(110)	150	(185)	300	350	6.0 <sup>[6]</sup> 20" W, 20" D	2155JB-F480LK_ _ _	6.0 <sup>[6]</sup> 20" W, 20" D	2155JB-F480LJ_ _ _	
480	(132)	200	(200-250)	350-400	400-500					

- [1] Units at these voltages are not UL listed or CSA certified.  
 [2] Delivery program is PE-II in the United States and SC-II in Canada.  
 [3] The catalog numbers listed are not complete:  
 • Select the control voltage code from table on page 205 to identify the preferred control voltage (e.g., 2155JB-F108LKB).  
 • If horsepower rated, select the number from table on page 206 that corresponds to the nominal horsepower desired, (e.g., 2155JB-F108LKB-49).  
 • If kW rated, select the number from table on page 206 that corresponds to the nominal kW desired, (e.g., 2155JB-F108LKN-49K).  
 • Select the appropriate suffix from the table on page 212 to identify the circuit breaker type (e.g. 2155JB-F108LKB-49CA or 2155JB-F108LKB-49KCA).  
 [4] Requires minimum of 3.5 space factors for 45kW @380-415 V when circuit breaker suffix 'CT' or 'CM' is selected.  
 [5] Frame mounted unit, section does not have vertical wireway next to this unit. The design of these units is optimized for bottom entry of load cables. For top entry of load cables, consult the factory.  
 [6] Frame mounted unit, section does not have vertical wireway. Horizontal bus is 5" deeper than standard. The design of these units is optimized for bottom entry of load cables. For top entry of load cables, consult the factory.

12

Bulletin 2155J Space Factors with Unit Options

180

Rating (Amperes)	Space Factor for NEMA Type 1 and Type 1 w/ gasket Units								Space Factor for NEMA Type 12 Units							
	Standard Unit	With Option 13GF	With Option 13IC	With Options 13GF and 13IC	With Option 13HIC	With Options 13GF and 13HIC	With Options 13IC and 13HIC	With Options 13GF, 13IC and 13HIC	Standard Unit	With Option 13GF	With Option 13IC	With Options 13GF and 13IC	With Option 13HIC	With Options 13GF and 13HIC	With Options 13IC and 13HIC	With Options 13GF, 13IC and 13HIC
5	2.0								3.0							
25	2.0								3.0							
43	2.0				2.5		2.0		3.0							
60	2.0				2.5		2.0		3.0				3.5			
85	2.0				2.0 <sup>[1]</sup>		2.5		3.0				3.5			
	2.5 <sup>[2]</sup>				3.0 <sup>[2]</sup>		3.5 <sup>[2]</sup>									
108 - 135 <sup>[3]</sup>	2.5	3.0	2.5	3.0	3.5				3.5				4.0			
108 - 135 <sup>[4]</sup>	3.0	3.5	3.0	3.5	4.0				3.5	4.0	3.5	4.0	4.5			
201	6.0, 20" W								6.0, 20" W							
251	6.0, 20" W								6.0, 20" W							
317	6.0, 20" W, 20" D				6.0, 25" W, 20" D				6.0, 20" W, 20" D				6.0, 25" W, 20" D			
361	6.0, 20" W, 20" D				6.0, 25" W, 20" D				6.0, 20" W, 20" D				6.0, 25" W, 20" D			
480	6.0, 20" W, 20" D				6.0, 30" W, 20" D				6.0, 20" W, 20" D				6.0, 30" W, 20" D			

- [1] The following combination of option requires 2.5 space factors: Options 89\_ and 4T\_ or 4TL\_ or 5TL\_ and 9\_ (without Option 13IC).  
 [2] Space factor for 45kW applications @ 380V-415V when circuit suffix 'CT' or 'CM' is selected.  
 [3] Space factor when circuit breaker suffix 'CA' is selected.  
 [4] Space factor when circuit breaker suffix 'CT' or 'CM' is selected.



# Factory-Installed Options, Modifications, Accessories for Combination Soft Starter (SMC) Units

Multiple option numbers are separated by a dash and added to the base catalog number in ascending order.

181

Option	Description	SMC-3 <sup>[1]</sup>		SMC-Flex		Option Number	Delivery Program	
		2154H	2155H	2154J	2155J			
Push Buttons <sup>[2],[3]</sup>	START-STOP <sup>[4]</sup>	✓	✓	✓ <sup>[5]</sup>	✓ <sup>[5]</sup>	-1	SC	
	STOP	✓	✓	✓ <sup>[5]</sup>	✓ <sup>[5]</sup>	-1B		
	START-STOP and SOFT STOP			✓ <sup>[5]</sup>	✓ <sup>[5]</sup>	-1XA		
	START-STOP and PUMP STOP			✓ <sup>[6]</sup>	✓ <sup>[6]</sup>	-1XB		PE
	START-STOP and SLOW SPEED			✓ <sup>[5]</sup>	✓ <sup>[5]</sup>	-1XC		SC
	START-STOP and BRAKE			✓ <sup>[7]</sup>	✓ <sup>[7]</sup>	-1XD		PE
	START-STOP and ACCU-STOP			✓ <sup>[7]</sup>	✓ <sup>[7]</sup>	-1XE		
START-STOP, SLOW SPEED and BRAKE	<b>Note:</b> When SMC-Flex option 13XB is selected, the only push button option that can be selected is 1XB. When SMC-Flex option 13XD is selected, the only push button options that can be selected are 1XD, 1XE, or 1XF			✓ <sup>[7],[8]</sup>	✓ <sup>[7],[8]</sup>	-1XF		
Control Station Housing <sup>[9]</sup>	Blank	✓	✓	✓	✓	-2	SC	
	1 hole—for one pilot device	✓	✓	✓	✓	-2A		
	2 holes—for two pilot devices	✓	✓	✓	✓	-2B		
	3 holes—for three pilot devices	✓	✓	✓	✓	-2C		
	4 holes—for four pilot devices	✓	✓	✓	✓	-2D <sup>[10]</sup>		
Selector Switch <sup>[2],[11]</sup>	HAND-OFF-AUTO	✓	✓	✓	✓	-3	SC	
	OFF-ON	✓	✓	✓	✓	-3E <sup>[3]</sup>		
Selector Switch <sup>[2],[12]</sup>	HAND-OFF-AUTO for Soft Stop <sup>[13]</sup>			✓	✓	-3XA	PE	
	HAND-OFF-AUTO for Pump Control			✓	✓	-3XB	PE	
	HAND-OFF-AUTO for Smart Motor Braking <sup>[14]</sup>			✓	✓	-3XD	SC	

- [1] Pilot devices for 0.5 space factor units are Bulletin 800F. A minimum of 1.0 space factor is required for SMC-3 units when more than four pilot devices are required.
- [2] Maximum one (1) switch per unit. Push buttons may not be used in conjunction with selector switches. When three (3) or less pilot devices are selected, Bulletin 800T pilot devices are supplied, except selector switches are Bulletin 800H devices. Generally, when more than three (3) pilot devices are selected, Bulletin 800F pilot devices are supplied. For 0.5 space factor units, Bulletin 800F pilot devices are supplied. Maximum four (4) pilot devices on 0.5 space factor units. Only one push button or selector switch option may be selected.
- [3] Mutually exclusive with 13GC, 13GD, 13GE, 13GR and 13DSA.
- [4] Two (2) Bulletin 800F pilot lights will be supplied when two (2) pilot lights are selected in conjunction with two (2) push buttons.
- [5] Can only be used with standard starting mode for SMC-Flex.
- [6] Can only be used with Pump Control option 13XB for SMC-Flex.
- [7] Can only be used with Smart Motor Braking, Accu-Stop and Slow Speed with Braking option 13XD for SMC-Flex.
- [8] Option 1XF cannot be used with ON/OFF and fault pilot lights for SMC-Flex.
- [9] Available only on units without pilot devices. Holes are for Bulletin 800T pilot devices when unit is 1.0 space factor and larger. Holes are for Bulletin 800F pilot devices when unit is 0.5 space factor.
- [10] Not available for 1.0 space factor and larger units.
- [11] Selector switches 3 and 3E are not available when option 13XB or 13XD is selected.
- [12] These selector switches can only be used with corresponding control options (e.g. -3XA used only with standard starting mode, -3XB used only for 13XB and 3XD only used for 13XD).
- [13] Selector switch option 3XA functions when SMC-Flex is operating in Soft Stop mode. Consult factory if SMC-Flex will be operating in Preset Slow Speed mode.
- [14] Selector switch option 3XD functions when SMC-Flex is operating in Smart Motor Braking mode. Consult factory if SMC-Flex will be operating in Accu-Stop or Slow Speed Braking mode.

## Factory-Installed Options, Modifications, Accessories for Combination Soft Starter (SMC) Units

Multiple option numbers are separated by a dash and added to the base catalog number in ascending order. To select pilot light lens color, add letter(s) to the option number: A = amber, B = blue, C = clear, G = green, R = red, W = white (e.g., 4RG is a red ON and green OFF pilot light). Clear and white are not available for Bulletin 800T LED type pilot lights. Clear is not available on Bulletin 800F LED pilot lights. White is not available on Bulletin 800F incandescent pilot lights.

182

Option	Description		SMC-3 <sup>[1]</sup>		SMC-Flex		Option Number	Delivery Program
			2154H	2155H	2154J	2155J		
Pilot Lights (Transformer Type for 800T, Full-voltage for 800F) <sup>[2],[3]</sup>	Standard type	ON <sup>[4]</sup>	✓	✓	✓ <sup>[5]</sup>	✓ <sup>[5]</sup>	-4_	SC
		ON-OFF <sup>[2]</sup>	✓	✓	✓ <sup>[5]</sup>	✓ <sup>[5]</sup>	-4__	
		FAULT	✓ <sup>[6]</sup>	✓ <sup>[6]</sup>	✓	✓	-4T_	
	LED type	ON <sup>[4]</sup>	✓	✓	✓ <sup>[5]</sup>	✓ <sup>[5]</sup>	-4L_	
		ON-OFF <sup>[2]</sup>	✓	✓	✓ <sup>[5]</sup>	✓ <sup>[5]</sup>	-4L__	
		FAULT	✓ <sup>[6]</sup>	✓ <sup>[6]</sup>	✓	✓	-4TL_	
	Push-To-Test Standard Type	ON <sup>[4]</sup>	✓	✓	✓ <sup>[5]</sup>	✓ <sup>[5]</sup>	-5_	
		ON-OFF <sup>[2]</sup>	✓	✓	✓ <sup>[5]</sup>	✓ <sup>[5]</sup>	-5__	
		FAULT	✓ <sup>[6]</sup>	✓ <sup>[6]</sup>	✓	✓	-5T_	
	Push-To-Test LED Type	ON <sup>[4]</sup>	✓	✓	✓ <sup>[5]</sup>	✓ <sup>[5]</sup>	-5L_	
		ON-OFF <sup>[2]</sup>	✓	✓	✓ <sup>[5]</sup>	✓ <sup>[5]</sup>	-5L__	
		FAULT	✓ <sup>[6]</sup>	✓ <sup>[6]</sup>	✓	✓	-5TL_	

[1] Pilot devices for 0.5 space factor units are Bulletin 800F. A minimum of 1.0 space factor is required for SMC-3 units when more than four pilot devices are required.

[2] Select one (2) N.O. auxiliary contacts (option 900) for SMC-3 units with ON light and DeviceNet Starter Auxiliary (option 13DSA\_) when isolation contactor (option 13IC) is not selected. Select one (1) N.O. auxiliary contacts (option 90) for SMC-3 units with ON light and DeviceNet Starter Auxiliary (option 13DSA\_) and when isolation contactor (option 13IC) is selected.

[3] When three (3) or less pilot devices are selected, Bulletin 800T pilot devices are supplied, except selector switches are Bulletin 800H devices. Generally, when more than three (3) pilot devices are selected, Bulletin 800F pilot devices are supplied. For 0.5 space factor units, Bulletin 800F pilot devices are supplied. Maximum four (4) pilot devices on 0.5 space factor units.

[4] Select one (1) N.O. and one (1) N.C. auxiliary contact(option 901) when isolation contactor (option 13IC) is not selected. Select one (1) N.C. auxiliary contact(option 91) when isolation contactor (option 13IC) is selected. If used with DeviceNet Starter Auxiliary (option 13DSA\_), select isolation contactor (option 13IC) and (2) N.O. and one (1) N.C. auxiliary contact(option 9001)

[5] Select (1) N.O. auxiliary contact (Option 90) when ON pilot light is selected for SMC-Flex units. Select (1) N.O. and (1) N.C. auxiliary contact (Option 90 and 91) when ON-OFF pilot lights are selected for SMC-Flex units.

[6] Not available with DeviceNet Starter Auxiliary (Option 13DSA3).

## Factory-Installed Options, Modifications, Accessories for Combination Soft Starter (SMC) Units

Multiple option numbers are separated by a dash and added to the base catalog number in ascending order.

184

Option	Option Number	Description				SMC-3		SMC-Flex		Delivery Program	
						2154H	2155H	2154J	2155J		
Protective Modules	-13D	Protective module contains capacitors and metal oxide varistors (MOVs) which protect the internal power circuitry from severe electrical transients and high electrical noise	Line Side	480V MAX	3A-37A	✓	✓			SC	
					43A-85A	✓	✓				
					108A-135A	✓	✓				
					5A-85A			✓	✓		
					108A-480A			✓	✓		
				600V	3A-37A	✓	✓				PE in U.S., SC in Canada
					43A-85A	✓	✓				
					108A-135A	✓	✓				
					5A-85A			✓	✓		
					108A-480A			✓	✓		
	-13E	Load Side	480V MAX	43A-85A	✓	✓			SC		
				108A-135A	✓	✓					
				5A-85A			✓	✓			
				108A-480A			✓	✓			
600V			43A-85A	✓	✓			PE in U.S., SC in Canada			
			108A-135A	✓	✓						
			5A-85A			✓	✓				
			108A-480A			✓	✓				

## Factory-Installed Options, Modifications, Accessories for Combination Soft Starter (SMC) Units

Multiple option numbers are separated by a dash and added to the base catalog number in ascending order.

185

Option	Option Number	Description	SMC-3		SMC-Flex		Delivery Program	
			2154H	2155H	2154J	2155J		
DeviceNet Starter Auxiliary (mutually exclusive) <sup>[1]</sup>	-13DSA2	(4) 120VAC inputs and (2) 120VAC outputs for DeviceNet.	✓	✓	✓ <sup>[2]</sup>	✓ <sup>[2]</sup>	SC	
	-13DSA3	(4) 24VDC inputs and (2) 120VAC outputs for DeviceNet.	✓	✓	✓ <sup>[2]</sup>	✓ <sup>[2]</sup>		
Communication Modules (mutually exclusive)	-13GC	ControlNet communication module. Mounted internal to SMC-Flex. Includes one 1786-TPYS tap, supplied loose for customer mounting.			✓	✓		
	-13GD	DeviceNet communication module. Mounted internal to SMC-Flex.			✓	✓		
	-13GE	Ethernet communication module. Mounted internal to SMC-Flex.			✓	✓		
	-13GR	Single Point Remote I/O			✓	✓		
Ground Fault Current Transformer	-13GF	Provides ground fault core balance current transformer for ground fault indication			✓	✓		
Human Interface Module (HIM) (mutually exclusive)	-13HBA0	Blank Cover. No functionality			✓	✓		
	-13HBA3	LCD display, full numeric keypad	Door mounted in bezel. Cable to SMC Flex unit included. No window on door. Available on NEMA Type 1 and Type 1 with gasket only.			✓		✓
	-13HBA5	LCD display programmer only				✓		✓
	-13HC3S	LCD display, full numeric keypad	Door mounted. HIM is not removable from bezel. One HIM required per SMC Flex unit. No window on door. Available on NEMA 12 only.			✓	✓	
	-13HC5S	LCD display programmer only				✓	✓	
High Interrupting Capacity Fuses (Class J - Time Delay) <sup>[3]</sup>	-13HIC	Provides unit with high interrupting capacity fuses for increased short circuit withstand rating. See page 237 for short circuit withstand ratings of Bulletin 2155J units with this option.	Class J - Time Delay	3A-19A		✓		
				25A-37A		✓		
				43A-60A		✓		
				85A-108A		✓		
				135A		✓		
				5A			✓	
				25A			✓	
				43A-60A			✓	
				85A-108A			✓	
				135A-201A			✓	
				251A-361A			✓	
				Class L - Time Delay	480A			✓

[1] Not available with push buttons, selector switch (option 3E) and control relays (option 89C\_ or 89P\_). The addition of DeviceNet Starter Auxiliary (option 13DSA\_) may increase space factor of 2154H and 2155H SMC-3 units. See page 131 and page 132. Select (1) N.O. auxiliary contact (Option 90) when used with Bulletin 2154J and 2155J.

[2] When specifying options 13DSA2 or 13DSA3 with Bulletin 2154J and 2155J units, option 13GD must also be specified.

[3] Adding this option may require additional space for Bulletin 2155H units, see page 132 for space factors of units with this option. Adding this option may require additional space for Bulletin 2155J units, see page 135 for space factors of units with this option.

## Factory-Installed Options, Modifications, Accessories for Combination Soft Starter (SMC) Units

Multiple option numbers are separated by a dash and added to the base catalog number in ascending order

186

Option	Option Number	Description	SMC-3		SMC-Flex		Delivery Program	
			2154H	2155H	2154J	2155J		
Add Isolation Contactor <sup>[1]</sup>	-13IC	Provides unit with Bulletin 100 isolation contactor.	3A-19A	✓	✓	✓	✓	SC
			24A, 25A	✓	✓	✓	✓	
			30A-37A	✓	✓	✓	✓	
			43A	✓	✓	✓	✓	
			54A-60A	✓	✓	✓	✓	
			85A	✓	✓	✓	✓	
			97A-108A	✓	✓	✓	✓	
			135A-180A	✓	✓	✓	✓	
			201A-251A			✓	✓	
			317A-361A			✓	✓	
			480A-500A			✓	✓	
Standard Starting Mode <sup>[2], [3]</sup>	—	This starting mode group provides soft start, soft stop, current limit, full voltage, kick start, preset slow speed, linear speed start and stop and dual ramp. Refer to SMC-Flex Selection Guide, Publication 150-SG009x-EN-P, for detailed description of modes of operation.	5A-480A			✓	✓	
Pump Control <sup>[2], [4]</sup>	-13XB	This starting mode provides pump start and stop in addition to soft start, soft stop, current limit, full voltage and kick start. Refer to SMC-Flex Selection Guide, Publication 150-SG009x-EN-P, for detailed description of modes of operation.	5A-480A			✓	✓	PE
Braking Control Smart Motor Braking™, Accu-Stop™ and Slow Speed Braking <sup>[2], [5]</sup>	-13XD	This starting mode provides Smart Motor Braking, Accu-Stop and Slow Speed Braking in addition to soft start, soft stop, current limit, full voltage, kick start and preset slow speed. Refer to SMC-Flex Selection Guide, Publication 150-SG009x-EN-P, for detailed description of modes of operation.	5A-85A			✓	✓	
			108A			✓	✓	
			135A			✓	✓	
			201A			✓	✓	
			251A			✓	✓	
			317A			✓	✓	
			361A			✓	✓	
			480A			✓	✓	

[1] Adding this option may increase the space factor of the unit.

- For Bulletin 2154H, see page 131, for Bulletin 2155H, see page 132.

- For Bulletin 2154J, see page 134, for Bulletin 2155J, see page 135.

[2] Soft Start, Pump Stop, Smart Motor Braking, Accu-Stop and slow speed with braking are not intended to be used as an emergency stop

[3] Push Button option 1XA and 1XC and selector switch option 3XA can only be used with standard starting mode and are the only pushbutton and selector switch options that can be selected with standard starting mode.

[4] Push Button option 1XB and selector switch option 3XB can only be used with Pump Control (Option 13XB) and are the only pushbutton and selector switch options that can be selected with Pump Control.

[5] Push Button option 1XD, 1XE and 1XF and selector switch option 3XD can only be used with Smart Motor Braking, Accu-Stop and Slow Speed with Braking (Option 13XD) and are the only pushbutton and selector switch options that can be selected for Smart Motor Braking, Accu-Stop and Slow Speed with Braking (Option 13XD).

## Factory-Installed Options, Modifications, Accessories for Combination Soft Starter (SMC) Units

Multiple option numbers are separated by a dash and added to the base catalog number in ascending order.

190

Option	Option Number	Description	SMC-3		SMC-Flex		Delivery Program		
			2154H	2155H	2154J	2155J			
Surge Suppressor	-17R	Provides surge suppressor across coil of unwired control relays (option 89CF or 89P)	✓	✓	✓	✓	SC		
Omit Wiring	-19	Omission of control wiring	✓	✓	✓	✓			
Grounded Unit Door	-79GD	Hinge mounted ground strap mounted on bottom hinge of unit door. Unit door hinge grounding strap for IEC requirements.	✓	✓	✓	✓			
Unit Load Connector	-79L	Specify on all plug-in units in sections with vertical unit load ground bus	Unplated copper	✓	✓	✓		✓	
	-79LT		Tin plated copper	✓	✓	✓		✓	
Unit Ground Stab	—	Specify on plug-in units in sections with vertical plug-in ground bus. Copper unit ground stabs also may be used with steel vertical ground bus.	Copper alloy	✓	✓	✓		✓	
	-79U		Unplated copper	✓	✓	✓		✓	
	-79UT		Tin plated copper	✓	✓	✓		✓	
Unwired Control Relay <sup>[1]</sup>	-89CF40	Bulletin 700CF 4-Pole Relay	4 N.O.	✓	✓	✓		✓	SC
	-89CF31		3 N.O. and 1 N.C.	✓	✓	✓		✓	
	-89CF22		2 N.O. and 2 N.C.	✓	✓	✓	✓		
	-89CF40A	Bulletin 700CF 4-Pole Relay with Time Attachment	4 N.O.	✓	✓	✓	✓		
	-89CF22A		2 N.O. and 2 N.C.	✓	✓	✓	✓		
	-89CF40B	0.3 to 30 seconds	4 N.O.	✓	✓	✓	✓		
	-89CF22B		2 N.O. and 2 N.C.	✓	✓	✓	✓		
	-89CF40C	Bulletin 700CF 4-Pole Relay with Time Attachment	4 N.O.	✓	✓	✓	✓		
	-89CF22C		2 N.O. and 2 N.C.	✓	✓	✓	✓		
	-89CF40D		4 N.O.	✓	✓	✓	✓		
	-89CF22D	1.8 to 180 seconds	2 N.O. and 2 N.C.	✓	✓	✓	✓		
	-89CF40L	Bulletin 700CF 4-Pole Relay with Mechanical Latch Attachment	4 N.O.	✓	✓	✓	✓	PE	
	-89CF22L		2 N.O. and 2 N.C.	✓	✓	✓	✓		
	-89P2	Bulletin 700P Relay	2 N.O.		✓	✓	SC		
	-89P4		4 N.O.		✓	✓			
-89PT	Bulletin 700P with Pneumatic Time Delay Attachment (on/off delay) with two (2) timed contacts (0.1-60 sec)	None		✓	✓	PE			
-89PT2		2 N.O.		✓	✓				
-89PT4		4 N.O.		✓	✓				
-89PL2	Bulletin 700P Relay with Mechanical Latch Attachment	2 N.O.		✓	✓				

[1] Mutually exclusive with DeviceNet Starter Auxiliary (option 13DSA\_). The addition of unwired control relay (option 89CF) may increase the space factor of 2154H SMC-3 units. See page 131.

## Factory-Installed Options, Modifications, Accessories for Combination Soft Starter (SMC) Units

Multiple option numbers are separated by a dash and added to the base catalog number in ascending order.

191

Option	Option Number	Description	SMC-3		SMC-Flex		Delivery Program
			2154H	2155H	2154J	2155J	
Auxiliary Contacts Type B Wiring	-90	Normally Open—1 N.O. auxiliary contact mounted on isolation contactor (131C) when supplied	✓ <sup>[1]</sup>	✓ <sup>[1]</sup>	✓ <sup>[2]</sup>	✓ <sup>[2]</sup>	SC
	-91	Normally Closed—1 N.C. auxiliary contact mounted on isolation contactor (131C) when supplied	✓ <sup>[1]</sup>	✓ <sup>[1]</sup>	✓ <sup>[2]</sup>	✓ <sup>[2]</sup>	
	-98 <sup>[3]</sup>	Normally Open—1 N.O. mounted on operating mechanism (operates with movement of external handle only)	✓	✓	✓	✓	
	-98X <sup>[4]</sup>	Normally Open—1 N.O. mounted internally. Circuit breaker units only.		✓		✓	
	-99 <sup>[3]</sup>	Normally Closed—1 N.C. mounted on operating mechanism (operates with movement of external handle only)	✓	✓	✓	✓	
	-99X <sup>[4]</sup>	Normally Closed—1 N.C. mounted internally. Circuit breaker units only.		✓		✓	

- [1] The following apply to auxiliary contacts for Bulletin 2154H and 2155H SMC-3 units:
- Bulletin 150 SMC-3 controller includes one N.O. auxiliary contact set to NORMAL (unless otherwise specified below).
  - When isolation contactor (option -131C) is not selected, the maximum number of auxiliary contacts is two (2) in the following combinations (2) N.O. or (1) N.O. and (1) N.C. The auxiliary contacts are side-mounted on the SMC-3 and set to NORMAL. The standard SMC-3 N.O. auxiliary contact is set for AT SPEED and is not used.
  - When isolation contactor (option -131C) is selected, the maximum number auxiliary contacts is four (4) in any combination (except (3) N.C., (4) N.C., or (1) N.O. & (3) N.C.). These auxiliary contacts are on the isolation contactor. The standard SMC-3 N.O. auxiliary contact is set for NORMAL and is used to control the isolation contactor.
  - When ON pilot light or DeviceNet Starter Auxiliary (option -13DSA\_) is selected in SMC-3 units, without an isolation contactor and without any additional auxiliary contacts, the standard SMC-3 N.O. auxiliary contact will be used and set to NORMAL.
  - When ON pilot light or DeviceNet Starter Auxiliary (option -13DSA\_) is selected in SMC-3 units, without an isolation contactor, only one additional N.O. or N.C. contact may be selected, select (2) N.O. auxiliary contacts (option -900) or (1) N.O. and (1) N.C. auxiliary contacts (option -901). The auxiliary contacts are side-mounted on the SMC-3 and set to NORMAL. The standard SMC-3 N.O. auxiliary contact is set for AT SPEED and is not used.
  - When ON pilot light and DeviceNet Starter Auxiliary (option -13DSA\_) are selected in SMC-3 units, select (2) N.O. auxiliary contacts (option -900). Without an isolation contactor (option-131C) the auxiliary contacts are side-mounted on the SMC-3 and set to NORMAL. The standard SMC-3 N.O. auxiliary contact is set for AT SPEED and is not used.
  - When ON-OFF pilot lights are selected on SMC-3 units, select (1) N.O. auxiliary contact and (1) N.C. auxiliary contact (option -901). Without an isolation contactor (option-131C) the auxiliary contacts are side-mounted on the SMC-3 and set to NORMAL. The standard SMC-3 N.O. auxiliary contact is set for AT SPEED and is not used.
  - When ON-OFF pilot lights and DeviceNet Starter Auxiliary (option -13DSA\_) are selected on SMC-3 units, select (2) N.O. and (1) N.C. auxiliary contact (option -9001). **Note:** this number of auxiliary contacts requires the selection of an isolation contactor (option -131C).
- [2] The following apply to auxiliary contacts for Bulletin 2154J and 2155J SMC Flex units:
- When isolation contactor (Option 131C) is selected, the maximum number of auxiliary contacts is four (4) in any combination (except (3) N.C., (4) N.C., or (1) N.O. & (3) N.C.).
  - When isolation contactor (Option 131C) is **not** selected, the maximum number of auxiliary contacts is four (4) in the following combinations: (2) N.O. / (2) N.C., (3) N.O. / (1) N.C., (4) N.O. or (4) N.C.
  - When ON pilot light is selected on SMC-Flex units, select (1) N.O. auxiliary contact (option -90).
  - When ON-OFF pilot lights are selected on SMC-Flex units, select (1) N.O. and (1) N.C. auxiliary contact (option -90 and -91).
  - When DeviceNet Starter Auxiliary (-13DSA\_) is selected on SMC-Flex units, select (1) N.O. auxiliary contact (option -90).
- [3] The maximum number of auxiliary contacts that can be supplied is two (2), in any combination. Contacts actuate with movement of unit handle to ON or OFF position only. Contacts are not designed to actuate as a result of a circuit breaker trip. For such applications, auxiliary contacts "mounted internally" (98X or 99X) must be selected. Auxiliary contacts are supplied unwired.
- [4] The maximum number of auxiliary contacts that can be supplied internally is (2) N.O. and (2) N.C. (form C). Internal auxiliary contacts (98X or 99X) are wired to a 3-point unmounted terminal block.

## Factory-Installed Options, Modifications, Accessories for Combination Soft Starter (SMC) Units

Multiple option numbers are separated by a dash and added to the base catalog number in ascending order.

192

Option	Option Number	Description	SMC-3		SMC-Flex		Delivery Program	
			2154H	2155H	2154J	2155J		
T-Handle	-111	T-Handle latch on unit door	✓	✓	✓	✓	SC	
Control Circuit Wiring <sup>[1]</sup>	—	Type MTW (TEW) 90° C #16 AWG copper wire, VW1 rated	✓	✓	✓	✓		
	-750	Type MTW (TEW) 90° C #14 AWG (tinned) copper wire, VW1 rated	✓ [2]	✓ [2]	✓	✓		
	-750B	#14 AWG tinned, MTW, 90° C copper wire, VW1 rated and tinned power wire, including stab wires.	✓ [2]	✓ [2]	✓	✓		
	-750S	Type SIS 90° C #14 AWG (tinned) copper wire	✓ [2]	✓ [2]	✓	✓	SC (+2 days)	
Control Circuit Ring Lugs	-750RL <sup>[3]</sup>	Insulated ring lugs for control wires where possible	✓	✓	✓	✓		
Control Circuit Spade Lugs	-750SL <sup>[3]</sup>	Insulated spade lugs for control wires where possible	✓	✓	✓	✓	SC	
Control Wire Markers	-751D	Adhesive Brady Datab type markers at each end of control wire. Not available in Canada.	✓	✓	✓	✓		
	-751HS	Heat shrink type marker at each end of control wire	✓	✓	✓	✓		
	-751S	Sleeve type marker at each end of control wire	✓	✓	✓	✓		
Shunt Trip	-754 <sup>[4]</sup>	For tripping circuit breakers from remote 120V, 60Hz source		✓		✓	SC	
French Legend Plates	-860F	Legend plates printed in French are available on all pilot devices. Specify 860F when pilot device option is selected.	✓	✓	✓	✓		
Spanish Legend Plates	-860S	Legend plates printed in Spanish are available on all pilot devices. Specify 860S when pilot device option is selected.	✓	✓	✓	✓		
Unit Door Nameplates	—	Door Nameplate Screws	Plated steel nameplate screws. Provided when cardholder or nameplates are not selected.	✓	✓	✓	✓	SC-II
		Card Holder for Unit Doors	1.125" x 3.625" plastic card holders with blank cards	✓	✓	✓	✓	
		1.125" x 3.625" engraved 3-line or 4-line nameplate	Acrylic plate (available in U.S. only). Lettering is white with black letters or black with white letters.	✓	✓	✓	✓	
			Phenolic plate. Lettering is white with black letters, black with white letters, or red with white letters.	✓	✓	✓	✓	
Stainless Steel Nameplate Screws	—	Stainless steel nameplate screws for unit nameplates (2 per unit)	✓	✓	✓	✓	SC-II (+2 days)	
Export Packing Below Deck	—	Container is skid mounted and packaged in clear plastic. Packing is not watertight or waterproof. Considerations should be taken if extended storage is expected.	✓	✓	✓	✓		

13

[1] Options for factory wiring of control circuits. Device and component internal wiring and wiring that could affect operation or certification (e.g., insulation temperature class, EMC shielding requirements, communication requirements, UL, cUL, CSA, CE) are not included.

[2] Requires 0.5 space factor SMC-3 units to be increased to 1.0 space factor.

[3] Examples of where insulated lugs cannot be used include SMC terminals, Bulletin 800F pilot devices, 700CF relays, disconnects/circuit breakers and areas where more than one (1) wire per terminal is required.

[4] Not available when 2 N.O. and 2 N.C. (form C) internal contacts are selected for circuit breakers.

# Variable Frequency AC Motor Drive Units

## Bulletin 2162Q and 2163Q with PowerFlex 70 Drive ..... 149



These combination variable frequency AC motor drive units are specifically designed for use in CENTERLINE motor control centers. Each unit contains a high performance, microprocessor-controlled, variable frequency AC drive and either a fusible disconnect switch or a circuit breaker.

They also:

- Include isolated logic and power.
- Include fan(s) and venting where required. See page 243.
- Include internal electronic overload protection.
- Include EMC filters on 380-415VAC.
- Include UL Class J time delay fuses. These fuses provide both branch circuit protection and drive input protection. The drive input fuses are provided in series with the circuit breaker in Bulletin 2163Q units.
- Include control circuit transformer (CCT). The CCT is sized to provide power for all standard pilot devices and any required fan(s).
- Produce a three-phase, pulse width modulated (PWM) adjustable frequency output and voltage output for exceptional control of motor speed and torque.
- Are digitally programmable with access to mode programming, providing precise and repeatedly accurate setup, control and operation and adaptability to handle a variety of applications.

A Human Interface Module (HIM) and Control Platform Type **must** be selected.

Bulletin 2162Q and 2163Q use PowerFlex 70 drives.

Each unit is provided as a NEMA Wiring Class I, Type A unit with terminals mounted on the drive chassis for connection of remote pilot devices, input signals, etc. For NEMA Type 3R and NEMA Type 4 enclosure construction, contact your local Rockwell Automation Sales Office or Allen-Bradley distributor.

## Bulletin 2162R and 2163R with PowerFlex 700 Drive ..... 160



These combination variable frequency AC motor drive units are specifically designed for use in CENTERLINE motor control centers. Each unit contains a high performance, microprocessor-controlled, variable frequency AC drive and either a fusible disconnect switch or a circuit breaker.

They also:

- Include isolated logic and power.
- Include fan(s) and venting where required. See page 243.
- Include internal electronic overload protection.
- Include EMC filters on 380-415VAC.
- Include UL Class J time delay fuses. These fuses provide both branch circuit protection and drive input protection. The drive input fuses are provided in series with the circuit breaker in Bulletin 2163R units.
- Include control circuit transformer (CCT). The CCT is sized to provide power for all standard pilot devices and any required fan(s).
- Produce a three-phase, pulse width modulated (PWM) adjustable frequency output and voltage output for exceptional control of motor speed and torque.
- Are digitally programmable with access to mode programming, providing precise and repeatedly accurate set-up, control and operation and adaptability to handle a variety of applications.
- Have available 24VDC or 115VAC control voltages.
- A Human Interface Module (HIM) and Control Interface Type **must** be selected.
- Bulletin 2162R and 2163R use PowerFlex 700 drives.
- Each unit is provided as a NEMA Wiring Class I, Type A unit with terminals mounted on the drive chassis for connection of remote pilot devices, input signals, etc. For NEMA Type 3R and NEMA Type 4 enclosure construction, contact your local Rockwell Automation Sales Office or Allen-Bradley distributor.

### Bulletin 2162T and 2163T

#### PowerFlex 40 Drive ..... 171

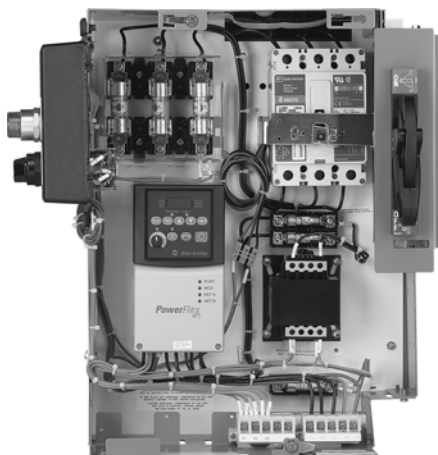

These combination variable frequency AC motor drive units are specifically designed for use in CENTERLINE motor control centers. Each unit contains a high performance, microprocessor-controlled, variable frequency AC drive and either a fusible disconnect switch or a circuit breaker.

They also:

- Include isolated logic and power.
- Include fan(s) and venting where required. See page 245.
- Include UL Class CC or J time delay fuses. These fuses provide both branch circuit protection and drive input protection. The drive input fuses are provided in series with the circuit breaker in Bulletin 2163T units.
- Include control circuit transformer (CCT). The CCT is sized to provide power for all standard pilot devices and any required fan(s).
- Produce a three-phase, pulse width modulated (PWM) adjustable frequency output and voltage output for exceptional control of motor speed and torque.
- Are digitally programmable with access to mode programming, providing precise and repeatedly accurate setup, control and operation and adaptability to handle a variety of applications.

Bulletin 2162T and 2163T use **normal duty** PowerFlex 40 drives.

Each unit is provided as a NEMA Wiring Class I, Type A unit with terminals mounted on the drive chassis for connection of remote pilot devices, input signals, etc. For NEMA Type 3R and NEMA Type 4 enclosure construction, contact your local Rockwell Automation Sales Office or Allen-Bradley distributor.

### Bulletin 2164Q, 2164R, 2165Q and 2165R

#### Manual Drive Bypass and PowerFlex 70 or PowerFlex 700 Drive ..... 176

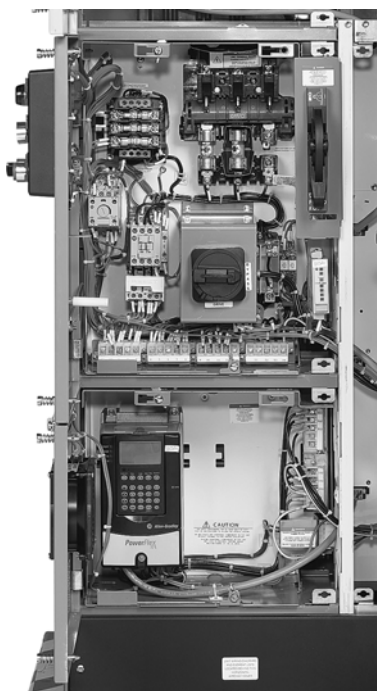

These combination variable frequency drive units are specially designed for use in CENTERLINE motor control centers. The configuration consists of two interlocked components, one containing the bypass circuitry and one containing a PowerFlex 70 (Bulletin 2164Q or 2165Q) or PowerFlex 700 (Bulletin 2164R or 2165R) variable frequency drive. The bypass component contains a fusible or circuit breaker disconnect, control circuit transformer, six-pole manually operated bypass switch, pull-apart terminal blocks and bypass contactor (Bulletin 100 contactor) with a Bulletin 193 overload relay. The drive compartment contains the respective PowerFlex variable frequency drive (see product descriptions on Bulletins 2162Q, 2162R, 2163Q and 2163R for specific PowerFlex 70 and 700 features) less control circuit transformer and disconnecting means. This configuration allows for the drive to be taken offline and replaced as needed with minimal disruption to the application process. When in bypass mode the serviceable drive component meets NFPA 70E hazard/Risk Level 0.

The bypass component is provided as a NEMA Class II wiring, Type B unit. Terminals mounted on the drive chassis are provided for the connection of remote devices, input signals, etc. Also

- A Human Interface Module must be specified.
- “Drive On” and “Bypass On” pilot lights and HAND-OFF-AUTO selector switch, HAND START and HAND STOP push buttons must be specified.
- Control Platform Type (Bulletin 2164Q, 2165Q) or Control Interface Type (Bulletin 2164R, 2165R) must be specified for Bulletins 2164R and 2165R.

Bulletin 2164Q and 2165Q use **normal duty** PowerFlex 70 drives.

Bulletin 2164R and 2165R use **normal duty** PowerFlex 700 drives.

For all NEMA Type 3R and NEMA Type 4 applications, contact your local Rockwell Automation Sales Office or Allen-Bradley distributor.

## Catalog Number Explanation - Bulletin 2160R

### PowerFlex 700H Variable Frequency AC Drive Load Reactor Unit

- Supplied in a unit separate from the drive
- Available in NEMA Enclosure Type 1 and Type 1 with gasket only
- NOTE: PowerFlex 700H drives have approximately 3% line reactance inherent to the device. Contact your local Rockwell Automation Sales Office for information

196

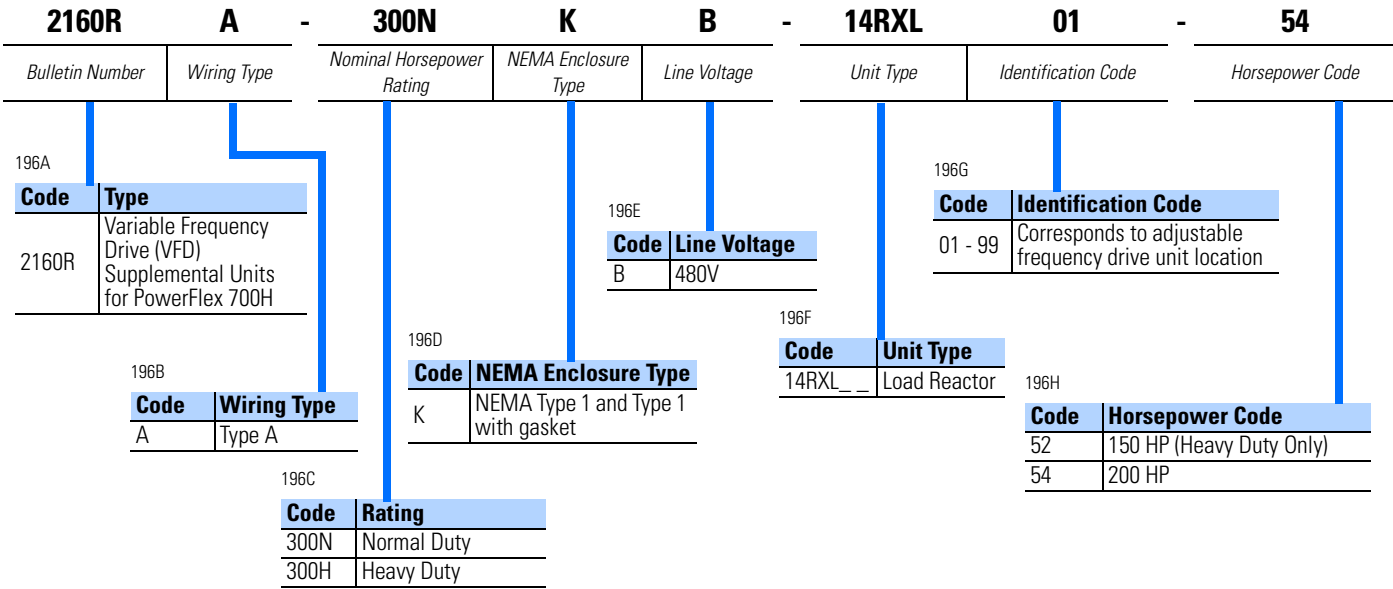

- See page 191 for a description of load reactor options and associated rules.
- Reactor unit is a separate unit from the drive unit.
- Reactor unit requires an additional section mounted to the right of the section with the drive unit. These two sections will create a shipping block.
- The reactor unit is to be mounted in the bottom of the section.
- The remaining space in the section with the load reactor is available for plug-in units.

197

Drive Rating	Nominal Horsepower <small>The horsepower ratings shown are nominal.</small>	Line Voltage	Space Factor	Catalog Number <sup>[1]</sup> NEMA Type 1 and Type 1 w/ gasket	Space Factor	Catalog Number <sup>[1]</sup> NEMA Type 12	Delivery Program
Heavy Duty	150	480	1.5 <sup>[2]</sup>	2160RA-300HKB-14RXL__-52	Available for NEMA Type 1 and Type 1 w/ gasket only		PE-II
	200	480		2160RA-300HKB-14RXL__-54			
Normal Duty	200	480		2160RA-300NKB-14RXL__-54			

[1] The catalog numbers listed are not complete:

- Select the drive supplementary unit identification code (01-99) (e.g., 2160RA-300NKB-14RXL01-54).
- The supplementary unit identification code must begin with "01" and continue sequentially ("02," "03," "04," etc.) Each reactor unit is to have a unique supplementary unit identification code that correlates with the same identification code on the drive unit.

[2] Frame mounted unit, must be located at the bottom of the section. Must be located in the adjacent section to the right of the corresponding drive location.

Catalog Number Explanation - Bulletin 2162Q and 2163Q

PowerFlex 70 Drive

- Bulletins 2162Q and 2163Q use PowerFlex 70 drives
- NEMA Enclosure Type 1, Type 1 with gasket or Type 12 Enclosure Type
- NEMA Wiring Class I, Type A
- Isolated logic and power produces a three-phase, pulse-width-modulated (PWM) adjustable frequency output to vary motor speed



207

<b>2162Q</b>	<b>A</b>	-	<b>1P1N</b>	<b>K</b>	<b>B</b>	-	<b>33</b>	-	<b>14HA0</b>
<b>2163Q</b>	<b>A</b>	-	<b>1P1N</b>	<b>K</b>	<b>B</b>	-	<b>33CA</b>	-	<b>14HA0</b>
<i>Bulletin Number</i>	<i>Wiring Type</i>		<i>PowerFlex 70 Nominal Output Current Rating</i>	<i>NEMA Enclosure Type</i>	<i>Line Voltage</i>		<i>Nominal Horsepower/kW and Circuit Breaker Type</i>		<i>Human Interface Module and Options</i>

207A

Code	Type
2162Q	PowerFlex 70 Variable Frequency AC Drive with Fusible Disconnect
2163Q	PowerFlex 70 Variable Frequency AC Drive with Circuit Breaker

207D

Code	NEMA Enclosure Type
K	NEMA Type 1 and Type 1 with gasket
J	NEMA Type 12

207F

Code	Nominal Horsepower/kW Code and Circuit Breaker Type
2162Q-"33"	"33" Nominal Horsepower/kW code. See table on page 206
2163Q-"33CA"	"33_" Nominal Horsepower/kW code. See table on page 206 " _CA" Circuit Breaker Type. See table on page 212

207B

Code	Wiring Type
A	Type A

207E

Code	Line Voltage
N	380V <sup>[1]</sup>
KN	400V <sup>[1]</sup>
I	415V <sup>[1]</sup>
B	480V
C	600V

207G

Code	Human Interface Module and Options
	See options section beginning on page 187

[1] Units at these voltages are not UL or cUL listed.

207C

Drive Size Code, Output Current Rating (Amperes) and Nominal hp or (kW) <sup>[1]</sup>														
Normal Duty Applications									Heavy Duty Applications					
380-415V Line Voltage			480V Line Voltage			600V Line Voltage			480V Line Voltage			600V Line Voltage		
Code	Ratings	kW	Code	Ratings	hp	Code	Ratings	hp	Code	Ratings	hp	Code	Ratings	hp
1P3N	1.3	0.37	1P1N	1.1	0.5	0P9N	0.9	0.5	2P1H	1.1	0.5	1P7H	0.9	0.5
2P1N	1.5	0.55	2P1N	1.6	0.75	1P7N	1.3	0.75	2P1H	1.6	0.75	1P7H	1.3	0.75
2P1N	2.1	0.75	2P1N	2.1	1	1P7N	1.7	1	3P4H	2.1	1	2P7H	1.7	1
3P5N	2.6	1.1	3P4N	3.0	1.5	2P7N	2.4	1.5	3P4H	3.0	1.5	2P7H	2.4	1.5
3P5N	3.5	1.5	3P4N	3.4	2	2P7N	2.7	2	5P0H	3.4	2	3P9H	2.7	2
5P0N	5.0	2.2	5P0N	5.0	3	3P9N	3.9	3	8P0H	5.0	3	6P1H	3.9	3
8P7N	8.7	3.7	8P0N	8.0	5	6P1N	6.1	5	011H	8.0	5	9P0H	6.1	5
011N	11.5	5.5	011N	11	7.5	9P0N	9.0	7.5	014H	11	7.5	011H	9.0	7.5
015N	15.4	7.5	014N	14	10	011N	11	10	022H	14	10	017H	11	10
022N	22	11	022N	22	15	017N	17	15	027H	22	15	022H	17	15
030N	30	15	027N	27	20	022N	22	20	034H	27	20	027H	22	20
037N	37	18.5	034N	34	25	027N	27	25	040H	34	25	032H	27	25
043N	43	22	040N	40	30	032N	32	30	052H	40	30	041H	32	30
060N	60	30	052N	52	40	041N	41	40	065H	52	40	052H	41	40
072N	72	37	065N	65	50	052N	52	50						

[1] The kW and HP ratings shown are for reference only. PowerFlex 70 drive units should be sized according to the applications and output ampere rating.

Combination PowerFlex 70 Variable Frequency AC Drive (VFD) Units with Fusible Disconnect, 380-415V (NORMAL DUTY)

- See page 145 for product description.
- Normal Duty Ratings, the drive overload capabilities (based on the output currents listed below) are: 110% for 60 seconds and 150% for 3 seconds.
- For specific drive applications refer to PowerFlex 70 User Manual.
- Branch circuit overload protection is provided by the internal drive overload.
- PowerFlex 70 drives are cUL US (UL and cUL listed) as motor overload protected devices. An external overload relay is not required for single motor applications. PowerFlex 70 AC drives are not intended for use with single phase motors.
- See page 238 for Combination Unit Short Circuit Withstand Ratings table.
- Wiring is Type A only. Drive can accept 16 AWG control wire maximum.
- Proper placement of drive units in the MCC is essential for proper operation and life cycle of the drive. Strong consideration should be given to placing units with drives at the bottom of the section. When more than one drive unit is placed in a section, the drive unit with the highest rating should be located at the bottom of the section.
- Do not mount transformer units below drive units. Heat from transformer units may cause drive to trip.
- HIM (Human Interface Module) and Control Platform Type are required. Select on page 189 and 190.
- Combination VFD units at these voltages are not UL or cUL listed.

208

Frame	Maximum Continuous Output Amperes [1]	Nominal kW	NEMA Type 1 and Type 1 w/ gasket		NEMA Type 12		Delivery Program
		The horsepower and kW ratings shown below are for reference only. PowerFlex 70 drive units should be sized according to the application and output ampere rating.	Space Factor	Catalog Number [2]	Space Factor	Catalog Number [2]	
B	1.3	0.37	1.5	2162QA-1P3NK_-33K	2.0	2162QA-1P3NJ_-33K	PE
	1.5	0.55		2162QA-2P1NK_-34K		2162QA-2P1NJ_-34K	
	2.1	0.75		2162QA-2P1NK_-35K		2162QA-2P1NJ_-35K	
	2.6	1.1		2162QA-3P5NK_-36K		2162QA-3P5NJ_-36K	
	3.5	1.5		2162QA-3P5NK_-37K		2162QA-3P5NJ_-37K	
	5.0	2.2		2162QA-5P0NK_-38K		2162QA-5P0NJ_-38K	
	8.7	3.7		2162QA-8P7NK_-39K	2.5	2162QA-8P7NJ_-39K	
C	11.5	5.5	2.0	2162QA-011NK_-40K	3.0	2162QA-011NJ_-40K	
	15.4	7.5		2162QA-015NK_-41K		2162QA-015NJ_-41K	
D	22	11	2.5	2162QA-022NK_-42K	3.5	2162QA-022NJ_-42K	
	30	15		2162QA-030NK_-43K		2162QA-030NJ_-43K	
	37	18.5		2162QA-037NK_-44K		2162QA-037NJ_-44K	
	43	22	3.0	2162QA-043NK_-45K		2162QA-043NJ_-45K	
E	60	30	3.0 <sup>[3]</sup>	2162QA-060NK_-46K	4.0	2162QA-060NJ_-46K	
	72	37	3.5	2162QA-072NK_-47K		2162QA-072NJ_-47K	

[1] Ampere ratings are at a 4kHz carrier frequency. If carrier frequencies above 4kHz are selected, the drive output ampere ratings **must** be derated. For derating information, contact your local Rockwell Automation Sales Office and/or refer to *PowerFlex 70/700 Reference Manual*, PFLEX-RM001x-EN-E.

[2] The catalog numbers listed are not complete: Select the appropriate voltage code: 380V = N, 400V = KN, 415 = I (e.g. 2162QA-1P3NKN-33K).

[3] Requires 3.5 total space factors when door mounted pilot devices are selected.

**Units—2162Q**

*Combination PowerFlex 70 Variable Frequency AC Drive (VFD) Units with Fusible Disconnect, 480V (NORMAL DUTY)*

- See page 145 for product description.
- Normal Duty Ratings, the drive overload capabilities (based on the output currents listed below) are: 110% for 60 seconds and 150% for 3 seconds.
- For specific drive applications refer to PowerFlex 70 User Manual.
- Branch circuit overload protection is provided by the internal drive overload.
- PowerFlex 70 drives are cUL US (UL and cUL listed) as motor overload protected devices. An external overload relay is not required for single motor applications. PowerFlex 70 AC drives are not intended for use with single phase motors.
- See page 238 for Combination Unit Short Circuit Withstand Ratings table.
- Wiring is Type A only. Drive can accept 16 AWG control wire maximum.
- Proper placement of drive units in the MCC is essential for proper operation and life cycle of the drive. Strong consideration should be given to placing units with drives at the bottom of the section. When more than one drive unit is placed in a section, the drive unit with the highest rating should be located at the bottom of the section.
- Do not mount transformer units below drive units. Heat from transformer units may cause drive to trip.
- HIM (Human Interface Module) and Control Platform Type are required. Select on page 189 and 190.

209

Frame	Maximum Continuous Output Amperes <sup>[1]</sup>	Nominal HP	NEMA Type 1 and Type 1 w/ gasket		NEMA Type 12		Delivery Program
		The horsepower and kW ratings shown below are for reference only. PowerFlex 70 drive units should be sized according to the application and output ampere rating.	Space Factor	Catalog Number	Space Factor	Catalog Number	
A	1.1	0.5	1.5	2162QA-1P1NKB-33	2.0	2162QA-1P1NJB-33	SC
	1.6	0.75		2162QA-2P1NKB-34		2162QA-2P1NJB-34	
	2.1	1		2162QA-2P1NKB-35		2162QA-2P1NJB-35	
	3.0	1.5		2162QA-3P4NKB-36		2162QA-3P4NJB-36	
	3.4	2		2162QA-3P4NKB-37		2162QA-3P4NJB-37	
B	5.0	3	2.5	2162QA-5P0NKB-38	2.5	2162QA-5P0NJB-38	
	8.0	5		2162QA-8P0NKB-39		2162QA-8P0NJB-39	
C	11	7.5	2.0	2162QA-011NKB-40	3.0	2162QA-011NJB-40	
	14	10		2162QA-014NKB-41		2162QA-014NJB-41	
D	22	15	2.5	2162QA-022NKB-42	3.5	2162QA-022NJB-42	
	27	20		2162QA-027NKB-43		2162QA-027NJB-43	
	34	25		2162QA-034NKB-44		2162QA-034NJB-44	
E	40	30	3.0	2162QA-040NKB-45	3.5	2162QA-040NJB-45	
	52	40	3.0 <sup>[2]</sup>	2162QA-052NKB-46	4.0	2162QA-052NJB-46	
	65	50	3.5 <sup>[3]</sup>	2162QA-065NKB-47	4.0 <sup>[3]</sup>	2162QA-065NJB-47	

[1] Ampere ratings are at a 4kHz carrier frequency. If carrier frequencies above 4kHz are selected, the drive output ampere ratings **must** be derated. For derating information, contact your local Rockwell Automation Sales Office and/or refer to *PowerFlex 70/700 Reference Manual*, PFLEX-RM001.x-EN-E.

[2] Requires 3.5 total space factors when door mounted pilot devices are selected and line or load reactor (-14RLX or -14RXL) is not selected.

Requires 4.0 total space factors when line or load reactor (-14RLX or -14RXL) is selected.

[3] Requires 6.0 total space factors, 20" wide, frame mounted (section does not have vertical wireway), when line or load reactor (-14RLX or -14RXL) is selected. Delivery program changes to SC-II.

## Variable Frequency AC Motor Drive Units

### Units—2162Q

#### Combination PowerFlex 70 Variable Frequency AC Drive (VFD) Units with Fusible Disconnect, 480V (HEAVY DUTY)

- See page 145 for product description.
- Heavy Duty Ratings, the drive overload capabilities (based on the output currents listed below) are: 150% for 60 seconds and 200% for 3 seconds.
- For specific drive applications refer to PowerFlex 70 User Manual.
- Branch circuit overload protection is provided by the internal drive overload.
- PowerFlex 70 drives are cUL US (UL and cUL listed) as motor overload protected devices. An external overload relay is not required for single motor applications. PowerFlex 70 AC drives are not intended for use with single phase motors.
- See page 238 for Combination Unit Short Circuit Withstand Ratings table.
- Wiring is Type A only. Drive can accept 16 AWG control wire maximum.
- Proper placement of drive units in the MCC is essential for proper operation and life cycle of the drive. Strong consideration should be given to placing units with drives at the bottom of the section. When more than one drive unit is placed in a section, the drive unit with the highest rating should be located at the bottom of the section.
- Do not mount transformer units below drive units. Heat from transformer units may cause drive to trip.
- HIM (Human Interface Module) and Control Platform Type are required. Select on page 189 and 190.

210

Frame	Maximum Continuous Output Amperes [1]	Nominal HP	NEMA Type 1 and Type 1 w/ gasket		NEMA Type 12		Delivery Program
		The horsepower and kW ratings shown below are for reference only. PowerFlex 70 drive units should be sized according to the application and output ampere rating.	Space Factor	Catalog Number	Space Factor	Catalog Number	
A	1.1	0.5	1.5	2162QA-2P1HKB-33	2.0	2162QA-2P1HJB-33	SC
	1.6	0.75		2162QA-2P1HKB-34		2162QA-2P1HJB-34	
	2.1	1		2162QA-3P4HKB-35		2162QA-3P4HJB-35	
	3.0	1.5		2162QA-3P4HKB-36		2162QA-3P4HJB-36	
B	3.4	2	2.5	2162QA-5P0HKB-37	2.5	2162QA-5P0HJB-37	
	5.0	3		2162QA-8P0HKB-38		2162QA-8P0HJB-38	
C	8.0	5	2.0	2162QA-011HKB-39	3.0	2162QA-011HJB-39	
	11	7.5		2162QA-014HKB-40		2162QA-014HJB-40	
D	14	10	2.5	2162QA-022HKB-41	3.5	2162QA-022HJB-41	
	22	15		2162QA-027HKB-42		2162QA-027HJB-42	
	27	20		2162QA-034HKB-43		2162QA-034HJB-43	
E	34	25	3.0	2162QA-040HKB-44	3.5	2162QA-040HJB-44	
	40	30	3.0 <sup>[2]</sup>	2162QA-052HKB-45	4.0	2162QA-052HJB-45	
	52	40	3.5 <sup>[3]</sup>	2162QA-065HKB-46	4.0 <sup>[3]</sup>	2162QA-065HJB-46	

[1] Ampere ratings are at a 4kHz carrier frequency. If carrier frequencies above 4kHz are selected, the drive output ampere ratings **must** be derated. For derating information, contact your local Rockwell Automation Sales Office and/or refer to *PowerFlex 70/700 Reference Manual*, PFLEX-RM001x-EN-E.

[2] Requires 3.5 total space factors when door mounted pilot devices are selected and line or load reactor (-14RLX or -14RXL) is not selected. Requires 4.0 total space factors when line or load reactor (-14RLX or -14RXL) is selected.

[3] Requires 6.0 total space factors, 20" wide, frame mounted (section does not have vertical wireway), when line or load reactor (-14RLX or -14RXL) is selected. Delivery program changes to SC-II.

Units—2162Q

Combination PowerFlex 70 Variable Frequency AC Drive (VFD) Units with Fusible Disconnect, 600V (NORMAL DUTY)

- See page 145 for product description.
- Normal Duty Ratings, the drive overload capabilities (based on the output currents listed below) are: 110% for 60 seconds and 150% for 3 seconds.
- For specific drive applications refer to PowerFlex 70 User Manual.
- Branch circuit overload protection is provided by the internal drive overload.
- PowerFlex 70 drives are cUL US (UL and cUL listed) as motor overload protected devices. An external overload relay is not required for single motor applications. PowerFlex 70 AC drives are not intended for use with single phase motors.
- See page 238 for Combination Unit Short Circuit Withstand Ratings table.
- Wiring is Type A only. Drive can accept 16 AWG control wire maximum.
- Proper placement of drive units in the MCC is essential for proper operation and life cycle of the drive. Strong consideration should be given to placing units with drives at the bottom of the section. When more than one drive unit is placed in a section, the drive unit with the highest rating should be located at the bottom of the section.
- Do not mount transformer units below drive units. Heat from transformer units may cause drive to trip.
- HIM (Human Interface Module) and Control Platform Type are required. Select on page 189 and 190.

211

Frame	Maximum Continuous Output Amperes [1]	Nominal HP	NEMA Type 1 and Type 1 w/ gasket		NEMA Type 12		Delivery Program
		The horsepower ratings shown below are for reference only. PowerFlex 70 drive units should be sized according to the application and output ampere rating.	Space Factor	Catalog Number	Space Factor	Catalog Number	
A	0.9	0.5	1.5	2162QA-0P9NKC-33	2.0	2162QA-0P9NJC-33	PE in U.S. SC in Canada
	1.3	0.75		2162QA-1P7NKC-34		2162QA-1P7NJC-34	
	1.7	1		2162QA-1P7NKC-35		2162QA-1P7NJC-35	
	2.4	1.5		2162QA-2P7NKC-36		2162QA-2P7NJC-36	
	2.7	2		2162QA-2P7NKC-37		2162QA-2P7NJC-37	
B	3.9	3	2.5	2162QA-3P9NKC-38	2.5	2162QA-3P9NJC-38	
	6.1	5		2162QA-6P1NKC-39		2162QA-6P1NJC-39	
C	9.0	7.5	2.0	2162QA-9P0NKC-40	3.0	2162QA-9P0NJC-40	
	11	10		2162QA-011NKC-41		2162QA-011NJC-41	
D	17	15	2.5	2162QA-017NKC-42	3.5	2162QA-017NJC-42	
	22	20		2162QA-022NKC-43		2162QA-022NJC-43	
	27	25		3.0	2162QA-027NKC-44	2162QA-027NJC-44	
	32	30			2162QA-032NKC-45	2162QA-032NJC-45	
E	41	40	3.0 [2]	2162QA-041NKC-46	4.0	2162QA-041NJC-46	
	52	50		2162QA-052NKC-47		2162QA-052NJC-47	

[1] Ampere ratings are at a 4kHz carrier frequency. If carrier frequencies above 4kHz are selected, the drive output ampere ratings **must** be derated. For derating information, contact your local Rockwell Automation Sales Office and/or refer to *PowerFlex 70/700 Reference Manual*, PFLEX-RM001x-EN-E.

[2] Requires 3.5 total space factors when door mounted pilot devices are selected and line or load reactor (-14RLX or -14RXL) is not selected. Requires 4.0 total space factors when line or load reactor (-14RLX or -14RXL) is selected.

Combination PowerFlex 70 Variable Frequency AC Drive (VFD) Units with Fusible Disconnect, 600V (HEAVY DUTY)

- See page 145 for product description.
- Heavy Duty Ratings, the drive overload capabilities (based on the output currents listed below) are: 150% for 60 seconds and 200% for 3 seconds.
- For specific drive applications refer to PowerFlex 70 User Manual.
- Branch circuit overload protection is provided by the internal drive overload.
- PowerFlex 70 drives are cUL US (UL and cUL listed) as motor overload protected devices. An external overload relay is not required for single motor applications. PowerFlex 70 AC drives are not intended for use with single phase motors.
- See page 238 for Combination Unit Short Circuit Withstand Ratings table.
- Wiring is Type A only. Drive can accept 16 AWG control wire maximum.
- Proper placement of drive units in the MCC is essential for proper operation and life cycle of the drive. Strong consideration should be given to placing units with drives at the bottom of the section. When more than one drive unit is placed in a section, the drive unit with the highest rating should be located at the bottom of the section.
- Do not mount transformer units below drive units. Heat from transformer units may cause drive to trip.
- HIM (Human Interface Module) and Control Platform Type are required. Select on page 189 and 190.

212

Frame	Maximum Continuous Output Amperes <sup>[1]</sup>	Nominal HP		NEMA Type 1 and Type 1 w/ gasket		NEMA Type 12		Delivery Program
		The horsepower ratings shown below are for reference only. PowerFlex 70 drive units should be sized according to the application and output ampere rating.		Space Factor	Catalog Number	Space Factor	Catalog Number	
A	0.9	0.5		1.5	2162QA-1P7HKC-33	2.0	2162QA-1P7HJC-33	PE in U.S. SC in Canada
	1.3	0.75			2162QA-1P7HKC-34		2162QA-1P7HJC-34	
	1.7	1			2162QA-2P7HKC-35		2162QA-2P7HJC-35	
	2.4	1.5			2162QA-2P7HKC-36		2162QA-2P7HJC-36	
B	2.7	2		2162QA-3P9HKC-37	2162QA-3P9HJC-37	2.5	2162QA-3P9HJC-37	
	3.9	3		2162QA-6P1HKC-38	2162QA-6P1HJC-38			
C	6.1	5		2.0	2162QA-9P0HKC-39	3.0	2162QA-9P0HJC-39	
	9.0	7.5			2162QA-011HKC-40		2162QA-011HJC-40	
D	11	10		2.5	2162QA-017HKC-41	3.5	2162QA-017HJC-41	
	17	15			2162QA-022HKC-42		2162QA-022HJC-42	
	22	20			3.0	2162QA-027HKC-43	2162QA-027HJC-43	
	27	25				2162QA-032HKC-44	2162QA-032HJC-44	
E	32	30		3.0 <sup>[2]</sup>	4.0	2162QA-041HKC-45	2162QA-041HJC-45	
	41	40				2162QA-052HKC-46	2162QA-052HJC-46	

[1] Ampere ratings are at a 4kHz carrier frequency. If carrier frequencies above 4kHz are selected, the drive output ampere ratings **must** be derated. For derating information, contact your local Rockwell Automation Sales Office and/or refer to *PowerFlex 70/700 Reference Manual*, PFLEX-RM001x-EN-E.

[2] Requires 3.5 total space factors when door mounted pilot devices are selected and line or load reactor (-14RLX or -14RXL) is not selected. Requires 4.0 total space factors when line or load reactor (-14RLX or -14RXL) is selected.

Units—2163Q

Combination PowerFlex 70 Variable Frequency AC Drive (VFD) Units with Circuit Breaker Disconnect, 380-415V (NORMAL DUTY)

- See page 145 for product description.
- Normal Duty Ratings, the drive overload capabilities (based on the output currents listed below) are: 110% for 60 seconds and 150% for 3 seconds.
- For specific drive applications refer to PowerFlex 70 User Manual.
- Branch circuit overload protection is provided by the internal drive overload.
- PowerFlex 70 drives are cUL US (UL and cUL listed) as motor overload protected devices. An external overload relay is not required for single motor applications. PowerFlex 70 AC drives are not intended for use with single phase motors.
- See page 238 for Combination Unit Short Circuit Withstand Ratings table.
- Wiring is Type A only. Drive can accept 16 AWG control wire maximum.
- Proper placement of drive units in the MCC is essential for proper operation and life cycle of the drive. Strong consideration should be given to placing units with drives at the bottom of the section. When more than one drive unit is placed in a section, the drive unit with the highest rating should be located at the bottom of the section.
- Do not mount transformer units below drive units. Heat from transformer units may cause drive to trip.
- HIM (Human Interface Module) and Control Platform Type are required. Select on page 189 and 190.
- Combination VFD units at these voltages are not UL or cUL listed.

213

Frame	Maximum Continuous Output Amperes [1]	Nominal kW	NEMA Type 1 and Type 1 w/ gasket		NEMA Type 12		Delivery Program
		The horsepower and kW ratings shown below are for reference only. PowerFlex 70 drive units should be sized according to the application and output ampere rating.	Space Factor	Catalog Number <sup>[2]</sup>	Space Factor	Catalog Number	
B	1.3	0.37	1.5	2163QA-1P3NK_-33K_	2.0	2163QA-1P3NJ_-33K_	PE
	1.5	0.55		2163QA-2P1NK_-34K_		2163QA-2P1NJ_-34K_	
	2.1	0.75		2163QA-2P1NK_-35K_		2163QA-2P1NJ_-35K_	
	2.6	1.1		2163QA-3P5NK_-36K_		2163QA-3P5NJ_-36K_	
	3.5	1.5		2163QA-3P5NK_-37K_		2163QA-3P5NJ_-37K_	
	5.0	2.2		2163QA-5P0NK_-38K_		2163QA-5P0NJ_-38K_	
	8.7	3.7		2163QA-8P7NK_-39K_	2.5	2163QA-8P7NJ_-39K_	
C	11.5	5.5	2.0	2163QA-011NK_-40K_	3.0	2163QA-011NJ_-40K_	
	15.4	7.5		2163QA-015NK_-41K_		2163QA-015NJ_-41K_	
D	22	11	2.5	2163QA-022NK_-42K_		2163QA-022NJ_-42K_	
	30	15		2163QA-030NK_-43K_	2163QA-030NJ_-43K_		
	37	18.5	3.0	2163QA-037NK_-44K_	2163QA-037NJ_-44K_		
	43	22	3.5	2163QA-043NK_-45K_	2163QA-043NJ_-45K_		
E	60	30	3.0 <sup>[3]</sup>	2163QA-060NK_-46K_	4.0 <sup>[3]</sup>	2163QA-060NJ_-46K_	
	72	37	4.0	2163QA-072NK_-47K_	4.0	2163QA-072NJ_-47K_	

[1] Ampere ratings are at a 4kHz carrier frequency. If carrier frequencies above 4kHz are selected, the drive output ampere ratings **must** be derated. For derating information, contact your local Rockwell Automation Sales Office and/or refer to *PowerFlex 70/700 Reference Manual*, PFLX-RM001x-EN-E.

[2] The catalog numbers listed are not complete:

- Select the appropriate voltage code: 380V = N, 400V = KN, 415 = I (e.g. 2163QA-1P3NKN-33K).
- Select the appropriate suffix code from the circuit breaker table on page 212 to identify the desired circuit breaker type (e.g. 2163QA-1P3NKN-33K**CA**).

[3] Requires 3.5 total space factors when door mounted pilot devices are selected.

## Variable Frequency AC Motor Drive Units

### Units—2163Q

#### Combination PowerFlex 70 Variable Frequency AC Drive (VFD) Units with Circuit Breaker Disconnect, 480V (NORMAL DUTY)

- See page 145 for product description.
- Normal Duty Ratings, the drive overload capabilities (based on the output currents listed below) are: 110% for 60 seconds and 150% for 3 seconds.
- For specific drive applications refer to PowerFlex 70 User Manual.
- Branch circuit overload protection is provided by the internal drive overload.
- PowerFlex 70 drives are cUL US (UL and cUL listed) as motor overload protected devices. An external overload relay is not required for single motor applications. PowerFlex 70 AC drives are not intended for use with single phase motors.
- See page 238 for Combination Unit Short Circuit Withstand Ratings table.
- Wiring is Type A only. Drive can accept 16 AWG control wire maximum.
- Proper placement of drive units in the MCC is essential for proper operation and life cycle of the drive. Strong consideration should be given to placing units with drives at the bottom of the section. When more than one drive unit is placed in a section, the drive unit with the highest rating should be located at the bottom of the section.
- Do not mount transformer units below drive units. Heat from transformer units may cause drive to trip.
- HIM (Human Interface Module) and Control Platform Type are required. Select on page 189 and 190.

214

Frame	Maximum Continuous Output Amperes [1]	Nominal HP	NEMA Type 1 and Type 1 w/ gasket		NEMA Type 12		Delivery Program
		The horsepower and kW ratings shown below are for reference only. PowerFlex 70 drive units should be sized according to the application and output ampere rating.	Space Factor	Catalog Number [2]	Space Factor	Catalog Number [2]	
A	1.1	0.5	1.5	2163QA-1P1NKB-33_	2.0	2163QA-1P1NJB-33_	SC
	1.6	0.75		2163QA-2P1NKB-34_		2163QA-2P1NJB-34_	
	2.1	1		2163QA-2P1NKB-35_		2163QA-2P1NJB-35_	
	3.0	1.5		2163QA-3P4NKB-36_		2163QA-3P4NJB-36_	
	3.4	2		2163QA-3P4NKB-37_		2163QA-3P4NJB-37_	
B	5.0	3	2163QA-5P0NKB-38_	2.5	2163QA-5P0NJB-38_		
	8.0	5	2163QA-8P0NKB-39_		2163QA-8P0NJB-39_		
C	11	7.5	2.0	2163QA-011NKB-40_	3.0	2163QA-011NJB-40_	
	14	10		2163QA-014NKB-41_		2163QA-014NJB-41_	
D	22	15	2.5	2163QA-022NKB-42_	3.5	2163QA-022NJB-42_	
	27	20		2163QA-027NKB-43_		2163QA-027NJB-43_	
	34	25		2163QA-034NKB-44_		2163QA-034NJB-44_	
	40	30		2163QA-040NKB-45_		2163QA-040NJB-45_	
E	52	40	3.0 <sup>[3]</sup>	2163QA-052NKB-46_	4.0	2163QA-052NJB-46_	
	65	50	3.5 <sup>[4]</sup>	2163QA-065NKB-47_	4.0 <sup>[4]</sup>	2163QA-065NJB-47_	

[1] Ampere ratings are at a 4kHz carrier frequency. If carrier frequencies above 4kHz are selected, the drive output ampere ratings **must** be derated. For derating information, contact your local Rockwell Automation Sales Office and/or refer to *PowerFlex 70/700 Reference Manual*, PFLEX-RM001x-EN-E.

[2] The catalog numbers listed are not complete:

- Select the appropriate suffix code from the Circuit Breaker table on page 212 to identify the desired circuit breaker type (e.g. 2163QA-1P1NKB-33**CA**).

[3] Requires 3.5 total space factors when door mounted pilot devices are selected and line or load reactor (-14RLX or -14RXL) is not selected.

[4] Requires 4.0 total space factors when line or load reactor (-14RLX or -14RXL) is selected.

[4] Requires 6.0 total space factors, 20" wide, frame mounted (section does not have vertical wireway), when line or load reactor (-14RLX or -14RXL) is selected. Delivery program changes to SC-II.

Combination PowerFlex 70 Variable Frequency AC Drive (VFD) Units with Circuit Breaker Disconnect, 480V (HEAVY DUTY)

- See page 145 for product description.
- Heavy Duty Ratings, the drive overload capabilities (based on the output currents listed below) are: 150% for 60 seconds and 200% for 3 seconds.
- For specific drive applications refer to PowerFlex 70 User Manual.
- Branch circuit overload protection is provided by the internal drive overload.
- PowerFlex 70 drives are cUL US (UL and cUL listed) as motor overload protected devices. An external overload relay is not required for single motor applications. PowerFlex 70 AC drives are not intended for use with single phase motors.
- See page 238 for Combination Unit Short Circuit Withstand Ratings table.
- Wiring is Type A only. Drive can accept 16 AWG control wire maximum.
- Proper placement of drive units in the MCC is essential for proper operation and life cycle of the drive. Strong consideration should be given to placing units with drives at the bottom of the section. When more than one drive unit is placed in a section, the drive unit with the highest rating should be located at the bottom of the section.
- Do not mount transformer units below drive units. Heat from transformer units may cause drive to trip.
- HIM (Human Interface Module) and Control Platform Type are required. Select on page 189 and 190.

215

Frame	Maximum Continuous Output Amperes [1]	Nominal HP	NEMA Type 1 and Type 1 w/ gasket		NEMA Type 12		Delivery Program
		The horsepower and kW ratings shown below are for reference only. PowerFlex 70 drive units should be sized according to the application and output ampere rating.	Space Factor	Catalog Number [2]	Space Factor	Catalog Number	
A	1.1	0.5	1.5	2163QA-2P1HKB-33_	2.0	2163QA-2P1HJB-33_	SC
	1.6	0.75		2163QA-2P1HKB-34_		2163QA-2P1HJB-34_	
	2.1	1		2163QA-3P4HKB-35_		2163QA-3P4HJB-35_	
	3.0	1.5		2163QA-3P4HKB-36_		2163QA-3P4HJB-36_	
B	3.4	2	2.5	2163QA-5P0HKB-37_	2.5	2163QA-5P0HJB-37_	
	5	3		2163QA-8P0HKB-38_		2163QA-8P0HJB-38_	
C	8	5	2.0	2163QA-011HKB-39_	3.0	2163QA-011HJB-39_	
	11	7.5		2163QA-014HKB-40_		2163QA-014HJB-40_	
D	14	10	2.5	2163QA-022HKB-41_	3.5	2163QA-022HJB-41_	
	22	15		2163QA-027HKB-42_		2163QA-027HJB-42_	
	27	20		3.0	2163QA-034HKB-43_	2163QA-034HJB-43_	
	34	25			2163QA-040HKB-44_	2163QA-040HJB-44_	
E	40	30	3.0 <sup>[3]</sup>	2163QA-052HKB-45_	4.0	2163QA-052HJB-45_	
	52	40	3.5 <sup>[4]</sup>	2163QA-065HKB-46_	4.0 <sup>[4]</sup>	2163QA-065HJB-46_	

14

[1] Ampere ratings are at a 4kHz carrier frequency. If carrier frequencies above 4kHz are selected, the drive output ampere ratings **must** be derated. For derating information, contact your local Rockwell Automation Sales Office and/or refer to *PowerFlex 70/700 Reference Manual*, PFLEX-RM001x-EN-E.

[2] The catalog numbers listed are not complete.

- Select the appropriate suffix code from the Circuit Breaker Table on page 212 to identify the desired circuit breaker type (e.g. 2163QA-1P1NKB-33**CA**).

[3] Requires 3.5 total space factors when door mounted pilot devices are selected and line or load reactor (-14RLX or -14RXL) is not selected.

[4] Requires 6.0 total space factors, 20" wide, frame mounted (section does not have vertical wireway), when line or load reactor (-14RLX or -14RXL) is selected. Delivery program changes to SC-II.

## Variable Frequency AC Motor Drive Units

### Units—2163Q

#### Combination PowerFlex 70 Variable Frequency AC Drive (VFD) Units with Circuit Breaker Disconnect, 600V (NORMAL DUTY)

- See page 145 for product description.
- Normal Duty Ratings, the drive overload capabilities (based on the output currents listed below) are: 110% for 60 seconds and 150% for 3 seconds.
- For specific drive applications refer to PowerFlex 70 User Manual.
- Branch circuit overload protection is provided by the internal drive overload.
- PowerFlex 70 drives are cUL US (UL and cUL listed) as motor overload protected devices. An external overload relay is not required for single motor applications. PowerFlex 70 AC drives are not intended for use with single phase motors.
- See page 238 for Combination Unit Short Circuit Withstand Ratings table.
- Wiring is Type A only. Drive can only accept 16 AWG control wire.
- Proper placement of drive units in the MCC is essential for proper operation and life cycle of the drive. Strong consideration should be given to placing units with drives at the bottom of the section. When more than one drive unit is placed in a section, the drive unit with the highest rating should be located at the bottom of the section.
- Do not mount transformer units below drive units. Heat from transformer units may cause drive to trip.
- HIM (Human Interface Module) and Control Platform Type are required. Select on page 189 and 190.

216

Frame	Maximum Continuous Output Amperes [1]	Nominal HP	NEMA Type 1 and Type 1 w/ gasket		NEMA Type 12		Delivery Program
		The horsepower ratings shown below are for reference only. PowerFlex 70 drive units should be sized according to the application and output ampere rating.	Space Factor	Catalog Number [2]	Space Factor	Catalog Number [2]	
A	0.9	0.5	1.5	2163QA-0P9NKC-33_	2.0	2163QA-0P9NJC-33_	PE in U.S. SC in Canada
	1.3	0.75		2163QA-1P7NKC-34_		2163QA-1P7NJC-34_	
	1.7	1		2163QA-1P7NKC-35_		2163QA-1P7NJC-35_	
	2.4	1.5		2163QA-2P7NKC-36_		2163QA-2P7NJC-36_	
	2.7	2		2163QA-2P7NKC-37_		2163QA-2P7NJC-37_	
B	3.9	3	2.5	2163QA-3P9NKC-38_	2.5	2163QA-3P9NJC-38_	
	6.1	5		2163QA-6P1NKC-39_		2163QA-6P1NJC-39_	
C	9.0	7.5	2.0	2163QA-9P0NKC-40_	3.0	2163QA-9P0NJC-40_	
	11	10		2163QA-011NKC-41_		2163QA-011NJC-41_	
D	17	15	2.5	2163QA-017NKC-42_	3.0	2163QA-017NJC-42_	
	22	20		2163QA-022NKC-43_		2163QA-022NJC-43_	
	27	25		2163QA-027NKC-44_		2163QA-027NJC-44_	
	32	30		2163QA-032NKC-45_		2163QA-032NJC-45_	
E	41	40	3.0 [3]	2163QA-041NKC-46_	4.0	2163QA-041NJC-46_	
	52	50		2163QA-052NKC-47_		2163QA-052NJC-47_	

[1] Ampere ratings are at a 4kHz carrier frequency. If carrier frequencies above 4kHz are selected, the drive output ampere ratings **must** be derated. For derating information, contact your local Rockwell Automation Sales Office and/or refer to *PowerFlex 70/700 Reference Manual*, PFLEX-RM001x-EN-E.

[2] The catalog number is not complete:

- Select the appropriate suffix code from the Circuit Breaker Table on page 212 to identify the desired circuit breaker type (e.g. 2163QA-0P9NKC-33**CA**).

[3] Requires 3.5 total space factors when door mounted pilot devices are selected and line or load reactor (-14RLX or -14RXL) is not selected. Requires 4.0 total space factors when line or load reactor (-14RLX or -14RXL) is selected.

Combination PowerFlex 70 Variable Frequency AC Drive (VFD) Units with Circuit Breaker Disconnect, 600V (HEAVY DUTY)

- See page 145 for product description.
- Heavy Duty Ratings, the drive overload capabilities (based on the output currents listed below) are: 150% for 60 seconds and 200% for 3 seconds.
- For specific drive applications refer to PowerFlex 70 User Manual.
- Branch circuit overload protection is provided by the internal drive overload.
- PowerFlex 70 drives are cUL US (UL and cUL listed) as motor overload protected devices. An external overload relay is not required for single motor applications. PowerFlex 70 AC drives are not intended for use with single phase motors.
- See page 238 for Combination Unit Short Circuit Withstand Ratings table.
- Wiring is Type A only. Drive can accept 16 AWG control wire maximum.
- Proper placement of drive units in the MCC is essential for proper operation and life cycle of the drive. Strong consideration should be given to placing units with drives at the bottom of the section. When more than one drive unit is placed in a section, the drive unit with the highest rating should be located at the bottom of the section.
- Do not mount transformer units below drive units. Heat from transformer units may cause drive to trip.
- HIM (Human Interface Module) and Control Platform Type are required. Select on page 189 and 190.

217

Frame	Maximum Continuous Output Amperes <sup>[1]</sup>	Nominal HP	NEMA Type 1 and Type 1 w/ gasket		NEMA Type 12		Delivery Program
		The horsepower ratings shown below are for reference only. PowerFlex 70 drive units should be sized according to the application and output ampere rating.	Space Factor	Catalog Number <sup>[2]</sup>	Space Factor	Catalog Number <sup>[2]</sup>	
A	0.9	0.5	1.5	2163QA-1P7HKC-33_	2.0	2163QA-1P7HJC-33_	PE in U.S. SC in Canada
	1.3	0.75		2163QA-1P7HKC-34_		2163QA-1P7HJC-34_	
	1.7	1		2163QA-2P7HKC-35_		2163QA-2P7HJC-35_	
	2.4	1.5		2163QA-2P7HKC-36_		2163QA-2P7HJC-36_	
B	2.7	2	2.5	2163QA-3P9HKC-37_	2.5	2163QA-3P9HJC-37_	
	3.9	3		2163QA-6P1HKC-38_		2163QA-6P1HJC-38_	
C	6.1	5	2.0	2163QA-9P0HKC-39_	3.0	2163QA-9P0HJC-39_	
	9	7.5		2163QA-011HKC-40_		2163QA-011HJC-40_	
D	11	10	2.5	2163QA-017HKC-41_	3.5	2163QA-017HJC-41_	
	17	15		2163QA-022HKC-42_		2163QA-022HJC-42_	
	22	20		3.0	2163QA-027HKC-43_	2163QA-027HJC-43_	
	27	25			2163QA-032HKC-44_	2163QA-032HJC-44_	
E	32	30	3.0 <sup>[3]</sup>	2163QA-041HKC-45_	4.0	2163QA-041HJC-45_	
	41	40		2163QA-052HKC-46_		2163QA-052HJC-46_	

[1] Ampere ratings are at a 4kHz carrier frequency. If carrier frequencies above 4kHz are selected, the drive output ampere ratings **must** be derated. For derating information, contact your local Rockwell Automation Sales Office and/or refer to *PowerFlex 70/700 Reference Manual*, PFLEX-RM001.x-EN-E.

[2] The catalog number is not complete:  
 • Select the appropriate suffix code from the Circuit Breaker Table on page 212 to identify the desired circuit breaker type (e.g. 2163QA-0P9HKC-33**CA**).

[3] Requires 3.5 total space factors when door mounted pilot devices are selected and line or load reactor (-14RLX or -14RXL) is not selected.  
 Requires 4.0 total space factors when line or load reactor (-14RLX or -14RXL) is selected.

## Variable Frequency AC Motor Drive Units

### Catalog Number Explanation - Bulletin 2162R and 2163R

#### PowerFlex 700 Drive

- Bulletins 2162R and 2163R use PowerFlex 700 Drives
- NEMA Enclosure Type 1, Type 1 with gasket or Type 12 Enclosure Type
- Class J time delay drive input fuses provide both branch circuit and drive input protection
- Isolated logic and power produces a three-phase, pulse-width-modulated (PWM) adjustable frequency output to vary motor speed



218

<b>2162R</b>	<b>A</b>	-	<b>034N</b>	<b>K</b>	<b>B</b>	-	<b>44</b>	-	<b>14HA0</b>
<b>2163R</b>	<b>A</b>	-	<b>034N</b>	<b>K</b>	<b>B</b>	-	<b>44CA</b>	-	<b>14HA0</b>
<i>Bulletin Number</i>	<i>Wiring Type</i>		<i>PowerFlex 700 Nominal Output Current Rating</i>	<i>NEMA Enclosure Type</i>	<i>Line Voltage</i>		<i>Nominal Horsepower/kW and Circuit Breaker Type</i>		<i>Human Interface Module and Options</i>

218A		218D		218F	
<b>Code</b>	<b>Type</b>	<b>Code</b>	<b>NEMA Enclosure Type</b>	<b>Code</b>	<b>Nominal Horsepower/kW Code and Circuit Breaker Type</b>
2162R	PowerFlex 700 Variable Frequency AC Drive with Fusible Disconnect	K	NEMA Type 1 or Type 1 with gasket	2162R-"33"	"33_" Nominal Horsepower/kW code. See table on page 206
2163R	PowerFlex 700 Variable Frequency AC Drive with Circuit Breaker	J	NEMA Type 12	2163R-"33CA"	"33_" Nominal Horsepower/kW code. See table on page 206 "CA" Circuit Breaker Type. See table on page 212

218B		218E		218G	
<b>Code</b>	<b>Wiring Type</b>	<b>Code</b>	<b>Line Voltage</b>	<b>Code</b>	<b>Human Interface Module and Options</b>
A	Type A	N	380V <sup>[1]</sup>		See options section beginning on page 187
		KN	400V <sup>[1]</sup>		
		I	415V <sup>[1]</sup>		
		B	480V		
		C	600V		

[1] Units at these voltages are not UL or cUL listed.

218C

#### Drive Size Code, Output Current Rating (Amperes) and Nominal hp or (kw)<sup>[1]</sup>

Normal Duty Applications									Heavy Duty Applications					
380-415V Line Voltage			480V Line Voltage			600V Line Voltage			480V Line Voltage			600V Line Voltage		
Code	Ratings	kW	Code	Ratings	hp	Code	Ratings	hp	Code	Ratings	hp	Code	Ratings	hp
1P3N	1.3	0.37	1P1N	1.1	0.5	1P7N	1.7	1	2P1H	1.1	0.5	2P7H	1.7	1
2P1N	1.5	0.55	2P1N	1.6	0.75	2P7N	2.4	1.5	2P1H	1.6	0.75	2P7H	2.4	1.5
2P1N	2.1	0.75	2P1N	2.1	1	2P7N	2.7	2	3P4H	2.1	1	3P9H	2.7	2
3P5N	2.6	1.1	3P4N	3.0	1.5	3P9N	3.9	3	3P4H	3.0	1.5	6P1H	3.9	3
3P5N	3.5	1.5	3P4N	3.4	2	6P1N	6.1	5	5P0H	3.4	2	9P0H	6.1	5
5P0N	5.0	2.2	5P0N	5.0	3	9P0N	9.0	7.5	8P0H	5.0	3	011H	9.0	7.5
8P7N	8.7	3.7	8P0N	8.0	5	011N	11	10	011H	8.0	5	017H	11	10
011N	11.5	5.5	011N	11	7.5	017N	17	15	014H	11	7.5	022H	17	15
015N	15.4	7.5	014N	14	10	022N	22	20	022H	14	10	027H	22	20
022N	22	11	022N	22	15	027N	27	25	027H	22	15	032H	27	25
030N	30	15	027N	27	20	032N	32	30	034H	27	20	041H	32	30
037N	37	18.5	034N	34	25	041N	41	40	040H	34	25	052H	41	40
043N	43	22	040N	40	30	052N	52	50	052H	40	30	062H	52	50
056N	56	30	052N	52	40	062N	62	60	065H	52	40	077H	62	60
072N	72	37	065N	65	50	077N	77	75	077H	65	50	125H	77	75
105N	85	45	077N	77	60	125N	99	100	096H	77	60	125H	99	100
105N	105	55	096N	96	75	125N	125	125	125H	96	75	144H	125	125
170N	138	75	125N	125	100	144N	144	150	156H	125	100			
170N	170	90	156N	156	125				180H	156	125			
300N	205	110	180N	180	150				300H	180	150			
300N	255	132	300N	255	200				300H	245	200			

[1] The kW and HP ratings shown are for reference only. PowerFlex 700 drive units should be sized according to the applications and output ampere rating.

Combination PowerFlex 700 Variable Frequency AC Drive (VFD) Units with Fusible Disconnect, 380-415VAC (NORMAL DUTY)

- See page 145 for product description.
- Normal Duty Ratings, the drive overload capabilities (based on the output currents listed below) are: 110% for 60 seconds and 150% for 3 seconds.
- For specific drive applications refer to the PowerFlex 700 User Manual.
- Branch circuit (overload) protection is provided by the internal drive overload.
- PowerFlex700 AC drives are cUL US (UL and cUL listed) as motor overload protected devices. An external overload relay is not required for single motor applications. PowerFlex 700 AC drives are not intended for use with single phase motors.
- See page 238 for Combination Unit Short Circuit Withstand Ratings table.
- Wiring is Type A only. Drive can accept 16 AWG control wire maximum.
- Proper placement of drive units in the MCC is essential for proper operation and life cycle of the drive. Strong consideration should be given to placing units with drives at the bottom of the section. When more than one drive unit is placed in a section, the drive unit with the highest rating should be located at the bottom of the section.
- Do not mount transformer units below drive units. Heat from transformer units may cause drive to trip.
- HIM (Human Interface Module) and Control Interface Type are required. Select on page 189 and 190.
- Combination VFD units at these voltages are not UL or cUL listed.

219

Frame	Maximum Continuous Output Amperes [1]	Nominal HP	NEMA Type 1 and Type 1 w/ gasket		NEMA Type 12		Delivery Program
		The horsepower and kW ratings shown below are for reference only. PowerFlex 700 drive units should be sized according to the application and output ampere rating.	Space Factor	Catalog Number <sup>[2]</sup>	Space Factor	Catalog Number	
Normal Duty							
0	1.3	0.37	2.0	2162RA-1P3NK_-33K	2.0	2162RA-1P3NJ_-33K	PE
	1.5	0.55		2162RA-2P1NK_-34K		2162RA-2P1NJ_-34K	
	2.1	0.75		2162RA-2P1NK_-35K		2162RA-2P1NJ_-35K	
	2.6	1.1		2162RA-3P5NK_-36K		2162RA-3P5NJ_-36K	
	3.5	1.5		2162RA-3P5NK_-37K		2162RA-3P5NJ_-37K	
	5.0	2.2		2162RA-5P0NK_-38K		2162RA-5P0NJ_-38K	
	8.7	3.7		2162RA-8P7NK_-39K		2162RA-8P7NJ_-39K	
	11.5	5.5		2162RA-011NK_-40K		2162RA-011NJ_-40K	
1	15.4	7.5	2.5	2162RA-015NK_-41K	2.5	2162RA-015NJ_-41K	
	22	11		2162RA-022NK_-42K		2162RA-022NJ_-42K	
2	30	15	2.5	2162RA-030NK_-43K	3.0	2162RA-030NJ_-43K	
	37	18.5		2162RA-037NK_-44K		2162RA-037NJ_-44K	
3	43	22	3.0	2162RA-043NK_-45K	3.5	2162RA-043NJ_-45K	
	56	30		2162RA-056NK_-46K		2162RA-056NJ_-46K	
	72	37		2162RA-072NK_-47K		2162RA-072NJ_-47K	
5	85	45	6.0, 25"W, 20"D <sup>[3]</sup>	2162RA-105NK_-48K	6.0, 25"W, 20"D <sup>[3]</sup>	2162RA-105NJ_-48K	
	105	55		2162RA-105NK_-49K		2162RA-105NJ_-49K	
6	138	75		6.0, 30"W, 20"D <sup>[3]</sup>	2162RA-170NK_-50K	6.0, 30"W, 20"D <sup>[3]</sup>	2162RA-170NJ_-50K
	170	90			2162RA-170NK_-51K		2162RA-170NJ_-51K
g <sup>[4]</sup>	205	110		6.0, 35"W, 20"D <sup>[3]</sup>	2162RAT-300NK_-52K	Available in NEMA Type 1 and Type 1 with gasket only	
				6.0, 30"W, 20"D <sup>[3]</sup>	2162RAB-300NK_-52K		
	6.0, 35"W, 20"D <sup>[3]</sup>	2162RAT-300NK_-53K					
	6.0, 30"W, 20"D <sup>[3]</sup>	2162RAB-300NK_-53K					

14

[1] Ampere ratings are at a 4kHz carrier frequency. If carrier frequencies above 4kHz are selected, the drive output current ratings **must** be derated. For derating information, contact your local Rockwell Automation Sales Office and/or refer to PowerFlex 70/700 Reference Manual, PFLEX-RM001x-EN-E.  
 [2] The catalog numbers listed are not complete:  
 • Select the appropriate voltage code (380V = N, 400V = KN, 415V = I) (e.g. 2162RA-1P3NKN-33K).  
 [3] Frame mounted unit, section does not have vertical wireway. Horizontal bus is 5" deeper than standard.  
 [4] Frame 9 is a PowerFlex 700H drive.

## Variable Frequency AC Motor Drive Units

### Units—2162R

#### Combination PowerFlex 700 Variable Frequency AC Drive (VFD) Units with Fusible Disconnect, 480VAC (NORMAL DUTY)

- See page 145 for product description.
- Normal Duty Ratings, the drive overload capabilities (based on the output currents listed below) are: 110% for 60 seconds and 150% for 3 seconds.
- For specific drive applications refer to the PowerFlex 700 User Manual.
- Branch circuit (overload) protection is provided by the internal drive overload.
- PowerFlex700 AC drives are cUL US (UL and cUL listed) as motor overload protected devices. An external overload relay is not required for single motor applications. PowerFlex 700 AC drives are not intended for use with single phase motors.
- See page 238 for Combination Unit Short Circuit Withstand Ratings table.
- Wiring is Type A only. Drive can accept 16 AWG control wire maximum.
- Proper placement of drive units in the MCC is essential for proper operation and life cycle of the drive. Strong consideration should be given to placing units with drives at the bottom of the section. When more than one drive unit is placed in a section, the drive unit with the highest rating should be located at the bottom of the section.
- Do not mount transformer units below drive units. Heat from transformer units may cause drive to trip.
- HIM (Human Interface Module) and Control Interface Type are required. Select on page 189 and 190.

220

Frame	Maximum Continuous Output Amperes <sup>[1]</sup>	Nominal HP	NEMA Type 1 and Type 1 w/ gasket		NEMA Type 12		Delivery Program
		The horsepower and kW ratings shown below are for reference only. PowerFlex 700 drive units should be sized according to the application and output ampere rating.	Space Factor	Catalog Number	Space Factor	Catalog Number	
		Normal Duty					
0	1.1	0.5	2.0	2162RA-1P1NKB-33	2.0	2162RA-1P1NJB-33	SC
	1.6	0.75		2162RA-2P1NKB-34		2162RA-2P1NJB-34	
	2.1	1		2162RA-2P1NKB-35		2162RA-2P1NJB-35	
	3.0	1.5		2162RA-3P4NKB-36		2162RA-3P4NJB-36	
	3.4	2		2162RA-3P4NKB-37		2162RA-3P4NJB-37	
	5.0	3		2162RA-5P0NKB-38		2162RA-5P0NJB-38	
	8.0	5		2162RA-8P0NKB-39		2162RA-8P0NJB-39	
	11	7.5		2162RA-011NKB-40		2162RA-011NJB-40	
1	14	10	2.5	2162RA-014NKB-41	2.5	2162RA-014NJB-41	
	22	15		2162RA-022NKB-42		2162RA-022NJB-42	
2	27	20	2.5	2162RA-027NKB-43	3.0	2162RA-027NJB-43	
	34	25		2162RA-034NKB-44		2162RA-034NJB-44	
3	40	30	3.0	2162RA-040NKB-45	3.5	2162RA-040NJB-45	
	52	40		2162RA-052NKB-46		2162RA-052NJB-46	
	65	50		2162RA-065NKB-47		2162RA-065NJB-47	
4	77	60	6.0, 20" W <sup>[2]</sup>	2162RA-077NKB-48	6.0, 25" W <sup>[2]</sup>	2162RA-077NJB-48	
5	96	75	6.0	2162RA-096NKB-49	6.0	2162RA-096NJB-49	
	125	100		2162RA-125NKB-50	25"W, 20"D <sup>[3]</sup>	2162RA-125NJB-50	
6	156	125	6.0 25"W, 20"D <sup>[3]</sup>	2162RA-156NKB-51	6.0 30"W, 20"D <sup>[3]</sup>	2162RA-156NJB-51	
	180	150		2162RA-180NKB-52	6.0 35"W, 20"D <sup>[3]</sup>	2162RA-180NJB-52	
g <sup>[4]</sup>	255	200	6.0, 35"W, 20"D <sup>[3]</sup>	2162RAT-300NKB-54	Available in NEMA Type 1 and Type 1 with gasket only	PE-II	
			6.0, 30"W, 20"D <sup>[3]</sup>	2162RAB-300NKB-54			

[1] Ampere ratings are at a 4kHz carrier frequency. If carrier frequencies above 4kHz are selected, the drive output current ratings **must** be derated. For derating information, contact your local Rockwell Automation Sales Office and/or refer to PowerFlex 70/700 Reference Manual, PFLEX-RM001x-EN-E.

[2] Frame mounted unit, section does not have vertical wireway.

[3] Frame mounted unit, section does not have vertical wireway. Horizontal bus is 5" deeper than standard.

[4] Frame 9 is a PowerFlex 700H drive.

**Units—2162R**

*Combination PowerFlex 700 Variable Frequency AC Drive (VFD) Units with Fusible Disconnect, 480VAC (HEAVY DUTY)*

- See page 145 for product description.
- Heavy Duty Ratings, the drive overload capabilities (based on the output currents listed below) are: 150% for 60 seconds and 200% for 3 seconds.
- For specific drive applications refer to the PowerFlex 700 User Manual.
- Branch circuit (overload) protection is provided by the internal drive overload.
- PowerFlex 700 drives are cUL US (UL and cUL listed) as motor overload protected devices. An external overload relay is not required for single motor applications. PowerFlex 700 AC drives are not intended for use with single phase motors.
- See page 238 for Combination Unit Short Circuit Withstand Ratings table.
- Wiring is Type A only. Drive can accept 16 AWG control wire maximum.
- Proper placement of drive units in the MCC is essential for proper operation and life cycle of the drive. Strong consideration should be given to placing units with drives at the bottom of the section. When more than one drive unit is placed in a section, the drive unit with the highest rating should be located at the bottom of the section.
- Do not mount transformer units below drive units. Heat from transformer units may cause drive to trip.
- HIM (Human Interface Module) and Control Interface Type are required. Select on page 189 and 190.

221

Frame	Maximum Continuous Output Amperes <sup>[1]</sup>	Nominal HP	NEMA Type 1 and Type 1 w/ gasket		NEMA Type 12		Delivery Program
		The horsepower and kW ratings shown below are for reference only. PowerFlex 700 drive units should be sized according to the application and output ampere rating.	Space Factor	Catalog Number	Space Factor	Catalog Number	
			Heavy Duty	480V			
0	1.1	0.5	2.0	2162RA-2P1HKB-33	2.0	2162RA-2P1HJB-33	SC
	1.6	0.75		2162RA-2P1HKB-34		2162RA-2P1HJB-34	
	2.1	1		2162RA-3P4HKB-35		2162RA-3P4HJB-35	
	3.0	1.5		2162RA-3P4HKB-36		2162RA-3P4HJB-36	
	3.4	2		2162RA-5P0HKB-37		2162RA-5P0HJB-37	
	5.0	3		2162RA-8P0HKB-38		2162RA-8P0HJB-38	
1	8.0	5	2.5	2162RA-011HKB-39	2.5	2162RA-011HJB-39	
	11	7.5		2162RA-014HKB-40		2162RA-014HJB-40	
	14	10		2162RA-022HKB-41		2162RA-022HJB-41	
2	22	15	2.5	2162RA-027HKB-42	3.0	2162RA-027HJB-42	
	27	20		2162RA-034HKB-43		2162RA-034HJB-43	
3	34	25	3.0	2162RA-040HKB-44	3.5	2162RA-040HJB-44	
	40	30		4.0	2162RA-052HKB-45	4.0	2162RA-052HJB-45
	52	40			2162RA-065HKB-46	4.0	2162RA-065HJB-46
4	65	50	6.0, 20"W <sup>[2]</sup>	2162RA-077HKB-47	6.0, 25"W <sup>[2]</sup>	2162RA-077HJB-47	
5	77	60	6.0	2162RA-096HKB-48	6.0	2162RA-096HJB-48	
	96	75		2162RA-125HKB-49	25"W, 20"D <sup>[3]</sup>	2162RA-125HJB-49	
6	125	100	6.0 25"W, 20"D <sup>[3]</sup>	2162RA-156HKB-50	6.0 30"W, 20"D <sup>[3]</sup>	2162RA-156HJB-50	
	156	125		2162RA-180HKB-51	6.0 35"W, 20"D <sup>[3]</sup>	2162RA-180HJB-51	
g <sup>[4]</sup>	180	150	6.0 35"W, 20"D <sup>[3]</sup>	2162RAT-300HKB-52	Available in NEMA Type 1 and Type 1 with gasket only	PE-II	
			6.0 30"W, 20"D <sup>[3]</sup>	2162RAB-300HKB-52			
	245	200	6.0, 35"W, 20"D <sup>[3]</sup>	2162RAT-300HKB-54			
			6.0, 30"W, 20"D <sup>[3]</sup>	2162RAB-300HKB-54			

14

[1] Ampere ratings are at a 4kHz carrier frequency. If carrier frequencies above 4kHz are selected, the drive output current ratings **must** be derated. For derating information, contact your local Rockwell Automation Sales Office and/or refer to PowerFlex 70/700 Reference Manual, PFLEX-RM001x-EN-E.  
 [2] Frame mounted unit, section does not have vertical wireway.  
 [3] Frame mounted unit, section does not have vertical wireway. Horizontal bus is 5" deeper than standard.  
 [4] Frame 9 is a PowerFlex 700H drive.

Combination PowerFlex 700 Variable Frequency AC Drive (VFD) Units with Fusible Disconnect, 600VAC (NORMAL DUTY)

- See page 145 for product description.
- Normal Duty Ratings, the drive overload capabilities (based on the output currents listed below) are: 110% for 60 seconds and 150% for 3 seconds.
- For specific drive applications refer to the PowerFlex 700 User Manual.
- Branch circuit (overload) protection is provided by the internal drive overload.
- PowerFlex700 AC drives are cUL US (UL and cUL listed) as motor overload protected devices. An external overload relay is not required for single motor applications. PowerFlex 700 AC drives are not intended for use with single phase motors.
- See page 238 for Combination Unit Short Circuit Withstand Ratings table.
- Wiring is Type A only. Drive can accept 16 AWG control wire maximum.
- Proper placement of drive units in the MCC is essential for proper operation and life cycle of the drive. Strong consideration should be given to placing units with drives at the bottom of the section. When more than one drive unit is placed in a section, the drive unit with the highest rating should be located at the bottom of the section.
- Do not mount transformer units below drive units. Heat from transformer units may cause drive to trip.
- HIM (Human Interface Module) and Control Interface Type are required. Select on page 189 and 190.

222

Frame	Maximum Continuous Output Amperes	Nominal HP	NEMA Type 1 and Type 1 w/ gasket		NEMA Type 12		Delivery Program
		The HP ratings shown below are for reference only. PowerFlex 700 drive units should be sized according to the application and output ampere rating.	Space Factor	Catalog Number	Space Factor	Catalog Number	
0	1.7 <sup>[1]</sup>	1	2.0	2162RA-1P7NKC-35	2.0	2162RA-1P7NJC-35	PE in U.S.,  SC in Canada
	2.4 <sup>[1]</sup>	1.5		2162RA-2P7NKC-36		2162RA-2P7NJC-36	
	2.7 <sup>[1]</sup>	2		2162RA-2P7NKC-37		2162RA-2P7NJC-37	
	3.9 <sup>[1]</sup>	3		2162RA-3P9NKC-38		2162RA-3P9NJC-38	
	6.1 <sup>[1]</sup>	5		2162RA-6P1NKC-39	2.5	2162RA-6P1NJC-39	
	9.0 <sup>[1]</sup>	7.5		2162RA-9P0NKC-40		2162RA-9P0NJC-40	
1	11 <sup>[1]</sup>	10	2.5	2162RA-011NKC-41	3.0	2162RA-011NJC-41	
	17 <sup>[1]</sup>	15		2162RA-017NKC-42		2162RA-017NJC-42	
2	22 <sup>[1]</sup>	20	2.5	2162RA-022NKC-43	3.0	2162RA-022NJC-43	
	27 <sup>[1]</sup>	25		2162RA-027NKC-44		2162RA-027NJC-44	
3	32 <sup>[1]</sup>	30	3.0	2162RA-032NKC-45	3.5	2162RA-032NJC-45	
	41 <sup>[1]</sup>	40		4.0	2162RA-041NKC-46	2162RA-041NJC-46	
	52 <sup>[1]</sup>	50			2162RA-052NKC-47	2162RA-052NJC-47	
4	62 <sup>[2]</sup>	60	6.0, 20"W <sup>[3]</sup>	2162RA-062NKC-48	6.0, 25"W <sup>[3]</sup>	2162RA-062NJC-48	
5	77 <sup>[2]</sup>	75	6.0, 25"W, 20"D <sup>[4]</sup>	2162RA-077NKC-49	6.0, 25"W, 20"D <sup>[4]</sup>	2162RA-077NJC-49	
6	99 <sup>[2]</sup>	100		2162RA-125NKC-50	6.0, 30"W, 20"D <sup>[4]</sup>	2162RA-125NJC-50	
	125 <sup>[2]</sup>	125		2162RA-125NKC-51	2162RA-125NJC-51		
	144 <sup>[2]</sup>	150		2162RA-144NKC-52	6.0, 35"W, 20"D <sup>[4]</sup>	2162RA-144NJC-52	

[1] Ampere ratings are at a 4kHz carrier frequency. If carrier frequencies above 4kHz are selected, the drive output current ratings **must** be derated. For derating information, contact your local Rockwell Automation Sales Office and/or refer to *PowerFlex 70/700 Reference Manual*, PFLEX-RM001x-EN-E.  
 [2] Ampere ratings are at 2kHz carrier frequency. If carrier frequencies above 2kHz are selected, the drive output current ratings **may** require derating. Contact your local Rockwell Automation Sales Office and to *PowerFlex 70/700 Reference Manual*, PFLEX-RM001x-EN-E.  
 [3] Frame mounted unit, section does not have vertical wireway.  
 [4] Frame mounted unit, section does not have vertical wireway. Horizontal bus is 5" deeper than standard.

Combination PowerFlex 700 Variable Frequency AC Drive (VFD) Units with Fusible Disconnect, 600VAC (HEAVY DUTY)

- See page 145 for product description.
- Heavy Duty Ratings, the drive overload capabilities (based on the output currents listed below) are: 150% for 60 seconds and 200% for 3 seconds.
- For specific drive applications refer to the PowerFlex 700 User Manual.
- Branch circuit (overload) protection is provided by the internal drive overload.
- PowerFlex 700 drives are cUL US (UL and cUL listed) as motor overload protected devices. An external overload relay is not required for single motor applications. PowerFlex 700 AC drives are not intended for use with single phase motors.
- See page 238 for Combination Unit Short Circuit Withstand Ratings table.
- Wiring is Type A only. Drive can accept 16 AWG control wire maximum.
- Proper placement of drive units in the MCC is essential for proper operation and life cycle of the drive. Strong consideration should be given to placing units with drives at the bottom of the section. When more than one drive unit is placed in a section, the drive unit with the highest rating should be located at the bottom of the section.
- Do not mount transformer units below drive units. Heat from transformer units may cause drive to trip.
- HIM (Human Interface Module) and Control Interface Type are required. Select on page 189 and 190.

223

Frame	Maximum Continuous Output Amperes	Nominal HP	NEMA Type 1 and Type 1 w/ gasket		NEMA Type 12		Delivery Program
		The HP ratings shown below are for reference only. PowerFlex 700 drive units should be sized according to the application and output ampere rating.	Space Factor	Catalog Number	Space Factor	Catalog Number	
			Heavy Duty	600V			
0	1.7 <sup>[1]</sup>	1	2.0	2162RA-2P7HKC-35	2.0	2162RA-2P7HJC-35	PE in U.S.,  SC in Canada
	2.4 <sup>[1]</sup>	1.5		2162RA-2P7HKC-36		2162RA-2P7HJC-36	
	2.7 <sup>[1]</sup>	2		2162RA-3P9HKC-37		2162RA-3P9HJC-37	
	3.9 <sup>[1]</sup>	3		2162RA-6P1HKC-38	2.5	2162RA-6P1HJC-38	
	6.1 <sup>[1]</sup>	5		2162RA-9P0HKC-39		2162RA-9P0HJC-39	
1	9.0 <sup>[1]</sup>	7.5	2162RA-011HKC-40	3.0	2162RA-011HJC-40		
	11 <sup>[1]</sup>	10	2162RA-017HKC-41		2162RA-017HJC-41		
2	17 <sup>[1]</sup>	15	2162RA-022HKC-42	3.5	2162RA-022HJC-42		
	22 <sup>[1]</sup>	20	2162RA-027HKC-43		2162RA-027HJC-43		
3	27 <sup>[1]</sup>	25	2162RA-032HKC-44	4.0	2162RA-032HJC-44		
	32 <sup>[1]</sup>	30	2162RA-041HKC-45		2162RA-041HJC-45		
	41 <sup>[1]</sup>	40	2162RA-052HKC-46	2162RA-052HJC-46			
4	52 <sup>[2]</sup>	50	6.0, 20"W <sup>[3]</sup>	2162RA-062HKC-47	6.0, 25"W <sup>[3]</sup>	2162RA-062HJC-47	
5	62 <sup>[2]</sup>	60	6.0, 25"W, 20"D <sup>[4]</sup>	2162RA-077HKC-48	6.0, 25"W, 20"D <sup>[4]</sup>	2162RA-077HJC-48	
6	77 <sup>[2]</sup>	75		2162RA-125HKC-49	6.0,	2162RA-125HJC-49	
	99 <sup>[2]</sup>	100		2162RA-125HKC-50	30"W, 20"D <sup>[4]</sup>	2162RA-125HJC-50	
	125 <sup>[2]</sup>	125		2162RA-144HKC-51	6.0, 35"W, 20"D <sup>[4]</sup>	2162RA-144HJC-51	

14

[1] Ampere ratings are at a 4kHz carrier frequency. If carrier frequencies above 4kHz are selected, the drive output current ratings **must** be derated. For derating information, contact your local Rockwell Automation Sales Office and/or refer to *PowerFlex 70/700 Reference Manual*, PFLEX-RM001x-EN-E.

[2] Ampere ratings are at 2kHz carrier frequency. If carrier frequencies above 2kHz are selected, the drive output current ratings **may** require derating. Contact your local Rockwell Automation Sales Office and to *PowerFlex 70/700 Reference Manual*, PFLEX-RM001x-EN-E.

[3] Frame mounted unit, section does not have vertical wireway.

[4] Frame mounted unit, section does not have vertical wireway. Horizontal bus is 5" deeper than standard.

## Variable Frequency AC Motor Drive Units

### Units—2163R

#### Combination PowerFlex 700 Variable Frequency AC Drive (VFD) Units with Circuit Breaker, 380-415VAC (NORMAL DUTY)

- See page 145 for product description.
- Normal Duty Ratings, the drive overload capabilities (based on the output currents listed below) are: 110% for 60 seconds and 150% for 3 seconds.
- For specific drive applications refer to the PowerFlex 700 User Manual.
- Branch circuit (overload) protection is provided by the internal drive overload.
- PowerFlex700 AC drives are cUL US (UL and cUL listed) as motor overload protected devices. An external overload relay is not required for single motor applications. PowerFlex 700 AC drives are not intended for use with single phase motors.
- See page 238 for Combination Unit Short Circuit Withstand Ratings table.
- Wiring is Type A only. Drive can accept 16 AWG control wire maximum.
- Proper placement of drive units in the MCC is essential for proper operation and life cycle of the drive. Strong consideration should be given to placing units with drives at the bottom of the section. When more than one drive unit is placed in a section, the drive unit with the highest rating should be located at the bottom of the section.
- Do not mount transformer units below drive units. Heat from transformer units may cause drive to trip.
- HIM (Human Interface Module) and Control Interface Type are required. Select on page 189 and 190.
- Combination VFD units at these voltages are not UL or cUL listed.

224

Frame	Maximum Continuous Output Amperes <sup>[1]</sup>	Nominal kW	NEMA Type 1 and Type 1 w/ gasket		NEMA Type 12		Delivery Program
		The horsepower and kW ratings shown below are for reference only. PowerFlex 700 drive units should be sized according to the application and output ampere rating.	Space Factor	Catalog Number <sup>[2]</sup>	Space Factor	Catalog Number <sup>[2]</sup>	
0	1.3	0.37	2.0	2163RA-1P3NK_-33K_	2.0	2163RA-1P3NJ_-33K_	PE
	1.5	0.55		2163RA-2P1NK_-34K_		2163RA-2P1NJ_-34K_	
	2.1	0.75		2163RA-2P1NK_-35K_		2163RA-2P1NJ_-35K_	
	2.6	1.1		2163RA-3P5NK_-36K_		2163RA-3P5NJ_-36K_	
	3.5	1.5		2163RA-3P5NK_-37K_		2163RA-3P5NJ_-37K_	
	5.0	2.2		2163RA-5P0NK_-38K_		2163RA-5P0NJ_-38K_	
	8.7	3.7		2163RA-8P7NK_-39K_		2163RA-8P7NJ_-39K_	
	11.5	5.5		2163RA-011NK_-40K_		2163RA-011NJ_-40K_	
1	15.4	7.5	2.5	2163RA-015NK_-41K_	2.5	2163RA-015NJ_-41K_	PE
	22	11		2163RA-022NK_-42K_		2163RA-022NJ_-42K_	
2	30	15	2.5	2163RA-030NK_-43K_	3.0	2163RA-030NJ_-43K_	PE
	37	18.5		2163RA-037NK_-44K_		2163RA-037NJ_-44K_	
3	43	22	3.0	2163RA-043NK_-45K_	3.5	2163RA-043NJ_-45K_	PE
	56	30		2163RA-056NK_-46K_		2163RA-056NJ_-46K_	
	72	37	3.5	2163RA-072NK_-47K_	2163RA-072NJ_-47K_		
5	85	45	6.0, 25"W, 20"D <sup>[3]</sup>	2163RA-105NK_-48K_	6.0, 25"W, 20"D <sup>[3]</sup>	2163RA-105NJ_-48K_	PE-II
	105	55		2163RA-105NK_-49K_		2163RA-105NJ_-49K_	
6	138	75	6.0, 30"W, 20"D <sup>[3]</sup>	2163RA-170NK_-50K_	6.0, 30"W, 20"D <sup>[3]</sup>	2163RA-170NJ_-50K_	PE-II
	170	90		2163RA-170NK_-51K_		2163RA-170NJ_-51K_	
g <sup>[4]</sup>	205	110	6.0, 30"W, 20"D <sup>[3],[5]</sup>	2163RAT-300NK_-52K_	Available in NEMA Type 1 and Type 1 with gasket only.		PE-II
				2163RAB-300NK_-52K_			
	2163RAT-300NK_-53K_						
	2163RAB-300NK_-53K_						
255	132						

[1] Ampere ratings are at a 4kHz carrier frequency. If carrier frequencies above 4kHz are selected, the drive output current ratings **must** be derated. For derating information, contact your local Rockwell Automation Sales Office and/or refer to PowerFlex 70/700 Reference Manual, PFLEX-RM001x-EN-E.

[2] The catalog numbers listed are not complete:

- Select the appropriate voltage code: 380V = N, 400V = KN, 415 = I (e.g. 2163RA-037NKN).
- Select the appropriate suffix from table on page 212 to identify the circuit breaker type (e.g. 2163RA-037NKN-44KCA).

[3] Frame mounted unit, section does not have vertical wireway. Horizontal bus is 5" deeper than standard.

[4] Frame 9 is a PowerFlex 700H drive.

[5] When specifying circuit breaker codes CT or CM on 132kW Bulletin 2163R drives, the width of the section increases to 35."

Combination PowerFlex 700 Variable Frequency AC Drive (VFD) Units with Circuit Breaker, 480VAC (NORMAL DUTY)

- See page 145 for product description.
- Normal Duty Ratings, the drive overload capabilities (based on the output currents listed below) are: 110% for 60 seconds and 150% for 3 seconds.
- For specific drive applications refer to the PowerFlex 700 User Manual.
- Branch circuit (overload) protection is provided by the internal drive overload.
- PowerFlex700 AC drives are cUL US (UL and cUL listed) as motor overload protected devices. An external overload relay is not required for single motor applications. PowerFlex 700 AC drives are not intended for use with single phase motors.
- See page 238 for Combination Unit Short Circuit Withstand Ratings table.
- Wiring is Type A only. Drive can accept 16 AWG control wire maximum.
- Proper placement of drive units in the MCC is essential for proper operation and life cycle of the drive. Strong consideration should be given to placing units with drives at the bottom of the section. When more than one drive unit is placed in a section, the drive unit with the highest rating should be located at the bottom of the section.
- Do not mount transformer units below drive units. Heat from transformer units may cause drive to trip.
- HIM (Human Interface Module) and Control Interface Type are required. Select on page 189 and 190.

225

Frame	Maximum Continuous Output Amperes [1]	Nominal HP	NEMA Type 1 and Type 1 w/ gasket		NEMA Type 12		Delivery Program
		The horsepower and kW ratings shown below are for reference only. PowerFlex 700 drive units should be sized according to the application and output ampere rating.	Space Factor	Catalog Number [2]	Space Factor	Catalog Number [2]	
0	1.1	0.5	2.0	2163RA-1P1NKB-33_	2.0	2163RA-1P1NJB-33_	SC
	1.6	0.75		2163RA-2P1NKB-34_		2163RA-2P1NJB-34_	
	2.1	1		2163RA-2P1NKB-35_		2163RA-2P1NJB-35_	
	3.0	1.5		2163RA-3P4NKB-36_		2163RA-3P4NJB-36_	
	3.4	2		2163RA-3P4NKB-37_		2163RA-3P4NJB-37_	
	5.0	3		2163RA-5P0NKB-38_		2163RA-5P0NJB-38_	
	8.0	5		2163RA-8P0NKB-39_		2163RA-8P0NJB-39_	
1	14	10	2.5	2163RA-011NKB-40_	2.5	2163RA-011NJB-40_	
	22	15		2163RA-014NKB-41_		2163RA-014NJB-41_	
2	27	20	2.5	2163RA-027NKB-43_	3.0	2163RA-027NJB-43_	
	34	25		2163RA-034NKB-44_		2163RA-034NJB-44_	
3	40	30	3.0	2163RA-040NKB-45_	3.5	2163RA-040NJB-45_	
	52	40		2163RA-052NKB-46_		2163RA-052NJB-46_	
	65	50	3.5	2163RA-065NKB-47_	2163RA-065NJB-47_		
4	77	60	6.0, 20" W[3]	2163RA-077NKB-48_	6.0, 25" W[3]	2163RA-077NJB-48_	
5	96	75	6.0	2163RA-096NKB-49_	25"W, 20"D[4]	2163RA-096NJB-49_	
	125	100		2163RA-125NKB-50_		2163RA-125NJB-50_	
6	156	125	6.0 25"W, 20"D[4]	2163RA-156NKB-51_	6.0 30"W, 20"D[4]	2163RA-156NJB-51_	
	180	150		2163RA-180NKB-52_		2163RA-180NJB-52_	
g[5]	255	200	6.0, 30"W, 20"D[4]	2163RAT-300NKB-54_ 2163RAB-300NKB-54_	Available in NEMA Type 1 and Type 1 with gasket only		PE-II

14

[1] Ampere ratings are at a 4kHz carrier frequency. If carrier frequencies above 4kHz are selected, the drive output current ratings **must** be derated. For derating information, contact your local Rockwell Automation Sales Office and/or refer to PowerFlex 70/700 Reference Manual, PFLEX-RM001x-EN-E.  
 [2] The catalog numbers listed are not complete:  
 • Select the appropriate suffix from table on page 212 to identify the circuit breaker type (e.g. 2163RA-034NKB-44**CA**).  
 [3] Frame mounted unit, section does not have vertical wireway.  
 [4] Frame mounted unit, section does not have vertical wireway. Horizontal bus is 5" deeper than standard.  
 [5] Frame 9 is a PowerFlex 700H drive.

## Variable Frequency AC Motor Drive Units

### Units—2163R

#### Combination PowerFlex 700 Variable Frequency AC Drive (VFD) Units with Circuit Breaker, 480VAC (HEAVY DUTY)

- See page 145 for product description.
- Heavy Duty Ratings, the drive overload capabilities (based on the output currents listed below) are: 150% for 60 seconds and 200% for 3 seconds.
- For specific drive applications refer to the PowerFlex 700 User Manual.
- Branch circuit (overload) protection is provided by the internal drive overload.
- PowerFlex 700 drives are cUL US (UL and cUL listed) as motor overload protected devices. An external overload relay is not required for single motor applications. PowerFlex 700 AC drives are not intended for use with single phase motors.
- See page 238 for Combination Unit Short Circuit Withstand Ratings table.
- Wiring is Type A only. Drive can accept 16 AWG control wire maximum.
- Proper placement of drive units in the MCC is essential for proper operation and life cycle of the drive. Strong consideration should be given to placing units with drives at the bottom of the section. When more than one drive unit is placed in a section, the drive unit with the highest rating should be located at the bottom of the section.
- Do not mount transformer units below drive units. Heat from transformer units may cause drive to trip.
- HIM (Human Interface Module) and Control Interface Type are required. Select on page 189 and 190.

226

Frame	Maximum Continuous Output Amperes <sup>[1]</sup>	Nominal HP	NEMA Type 1 and Type 1 w/ gasket		NEMA Type 12		Delivery Program	
		The horsepower and kW ratings shown below are for reference only. PowerFlex 700 drive units should be sized according to the application and output ampere rating.	Space Factor	Catalog Number <sup>[2]</sup>	Space Factor	Catalog Number <sup>[2]</sup>		
	Heavy Duty	480V						
0	1.1	0.5	2.0	2163RA-2P1HKB-33_	2.0	2163RA-2P1HJB-33_	SC	
	1.6	0.75		2163RA-2P1HKB-34_		2163RA-2P1HJB-34_		
	2.1	1		2163RA-3P4HKB-35_		2163RA-3P4HJB-35_		
	3.0	1.5		2163RA-3P4HKB-36_		2163RA-3P4HJB-36_		
	3.4	2		2163RA-5P0HKB-37_		2163RA-5P0HJB-37_		
	5.0	3		2163RA-8P0HKB-38_		2163RA-8P0HJB-38_		
	8.0	5		2163RA-011HKB-39_		2163RA-011HJB-39_		
1	11	7.5	2.5	2163RA-014HKB-40_	2.5	2163RA-014HJB-40_		
	14	10		2163RA-022HKB-41_		2163RA-022HJB-41_		
2	22	15	2.5	2163RA-027HKB-42_	3.0	2163RA-027HJB-42_		
	27	20		2163RA-034HKB-43_		2163RA-034HJB-43_		
3	34	25	3.0	2163RA-040HKB-44_	3.5	2163RA-040HJB-44_		
	40	30		2163RA-052HKB-45_		2163RA-052HJB-45_		
	52	40		2163RA-065HKB-46_		2163RA-065HJB-46_		
4	65	50	6.0, 20" W <sup>[3]</sup>	2163RA-077HKB-47_	6.0, 25" W <sup>[3]</sup>	2163RA-077HJB-47_	SC-II	
5	77	60	6.0 25"W, 20"D <sup>[4]</sup>	2163RA-096HKB-48_	6.0	2163RA-096HJB-48_		
	96	75		2163RA-125HKB-49_	25"W, 20"D <sup>[4]</sup>	2163RA-125HJB-49_		
6	125	100		6.0	2163RA-156HKB-50_	6.0		2163RA-156HJB-50_
	156	125		25"W, 20"D <sup>[4]</sup>	2163RA-180HKB-51_	6.0		2163RA-180HJB-51_
g <sup>[5]</sup>	180	150		6.0, 30"W, 20"D <sup>[4]</sup>	2163RAT-300HKB-52_	Available in NEMA Type 1 and Type 1 with gasket only		PE-II
	245	200	2163RAB-300HKB-52_					
			2163RAT-300HKB-54_					
			2163RAB-300HKB-54_					

[1] Ampere ratings are at a 4kHz carrier frequency. If carrier frequencies above 4kHz are selected, the drive output current ratings **must** be derated. For derating information, contact your local Rockwell Automation Sales Office and/or refer to PowerFlex 70/700 Reference Manual, PFLEX-RM001x-EN-E.

[2] The catalog numbers listed are not complete:

- Select the appropriate suffix from table on page 212 to identify the circuit breaker type (e.g. 2163RA-040HKB-44**CA**).

[3] Frame mounted unit, section does not have vertical wireway.

[4] Frame mounted unit, section does not have vertical wireway. Horizontal bus is 5" deeper than standard.

[5] Frame 9 is a PowerFlex 700H drive.

Combination PowerFlex 700 Variable Frequency AC Drive (VFD) Units with Circuit Breaker Disconnect, 600VAC (NORMAL DUTY)

- See page 145 for product description.
- Normal Duty Ratings, the drive overload capabilities (based on the output currents listed below) are: 110% for 60 seconds and 150% for 3 seconds.
- For specific drive applications refer to the PowerFlex 700 User Manual.
- Branch circuit (overload) protection is provided by the internal drive overload.
- PowerFlex700 AC drives are cUL US (UL and cUL listed) as motor overload protected devices. An external overload relay is not required for single motor applications. PowerFlex 700 AC drives are not intended for use with single phase motors.
- See page 238 for Combination Unit Short Circuit Withstand Ratings table.
- Wiring is Type A only. Drive can accept 16 AWG control wire maximum.
- Proper placement of drive units in the MCC is essential for proper operation and life cycle of the drive. Strong consideration should be given to placing units with drives at the bottom of the section. When more than one drive unit is placed in a section, the drive unit with the highest rating should be located at the bottom of the section.
- Do not mount transformer units below drive units. Heat from transformer units may cause drive to trip.
- HIM (Human Interface Module) and Control Interface Type are required. Select on page 189 and 190.

227

Frame	Maximum Continuous Output Amperes	Nominal HP	NEMA Type 1 and Type 1 w/ gasket		NEMA Type 12		Delivery Program
		The HP ratings shown below are for reference only. PowerFlex 700 drive units should be sized according to the application and output ampere rating.	Space Factor	Catalog Number <sup>[1]</sup>	Space Factor	Catalog Number <sup>[1]</sup>	
0	1.7 <sup>[2]</sup>	1	2.0	2163RA-1P7NKC-35_	2.0	2163RA-1P7NJC-35_	PE in U.S., SC in Canada
	2.4 <sup>[2]</sup>	1.5		2163RA-2P7NKC-36_		2163RA-2P7NJC-36_	
	2.7 <sup>[2]</sup>	2		2163RA-2P7NKC-37_		2163RA-2P7NJC-37_	
	3.9 <sup>[2]</sup>	3		2163RA-3P9NKC-38_		2163RA-3P9NJC-38_	
	6.1 <sup>[2]</sup>	5		2163RA-6P1NKC-39_	2163RA-6P1NJC-39_		
	9.0 <sup>[2]</sup>	7.5		2163RA-9P0NKC-40_	2163RA-9P0NJC-40_		
1	11 <sup>[2]</sup>	10	2.5	2163RA-011NKC-41_	3.0	2163RA-011NJC-41_	
	17 <sup>[2]</sup>	15		2163RA-017NKC-42_		2163RA-017NJC-42_	
2	22 <sup>[2]</sup>	20	2.5	2163RA-022NKC-43_	3.0	2163RA-022NJC-43_	
	27 <sup>[2]</sup>	25		2163RA-027NKC-44_		2163RA-027NJC-44_	
3	32 <sup>[2]</sup>	30	3.0	2163RA-032NKC-45_	3.5	2163RA-032NJC-45_	
	41 <sup>[2]</sup>	40		2163RA-041NKC-46_		2163RA-041NJC-46_	
	52 <sup>[2]</sup>	50		3.5	2163RA-052NKC-47_	2163RA-052NJC-47_	
4	62 <sup>[3]</sup>	60	6.0, 20"W <sup>[4]</sup>	2163RA-062NKC-48_	6.0, 25"W <sup>[4]</sup>	2163RA-062NJC-48_	
5	77 <sup>[3]</sup>	75	6.0, 25"W, 20"D <sup>[5]</sup>	2163RA-077NKC-49_	6.0, 25"W, 20"D <sup>[5]</sup>	2163RA-077NJC-49_	
6	99 <sup>[3]</sup>	100		6.0,	2163RA-125NKC-50_	6.0,	2163RA-125NJC-50_
	125 <sup>[3]</sup>	125		30"W, 20"D <sup>[5]</sup>	2163RA-125NKC-51_	30"W, 20"D <sup>[5]</sup>	2163RA-125NJC-51_
	144 <sup>[3]</sup>	150		6.0, 35"W, 20"D <sup>[5]</sup>	2163RA-144NKC-52_	6.0, 35"W, 20"D <sup>[5]</sup>	2163RA-144NJC-52_

14

[1] The catalog numbers listed are not complete:

- Select the appropriate suffix from table on page 212 to identify the circuit breaker type (e.g. 2163RA-027NKC-44**CA**).
- [2] Ampere ratings are at a 4kHz carrier frequency. If carrier frequencies above 4kHz are selected, the drive output current ratings **must** be derated. For derating information, contact your local Rockwell Automation Sales Office and/or refer to *PowerFlex 70/700 Reference Manual*, PFLEX-RM001x-EN-E.
- [3] Ampere ratings are at 2kHz carrier frequency. If carrier frequencies above 2kHz are selected, the drive output current ratings **may** require derating. Contact your local Rockwell Automation Sales Office and to *PowerFlex 70/700 Reference Manual*, PFLEX-RM001x-EN-E.
- [4] Frame mounted unit, section does not have vertical wireway.
- [5] Frame mounted unit, section does not have vertical wireway. Horizontal bus is 5" deeper than standard.

## Variable Frequency AC Motor Drive Units

### Units—2163R

#### Combination PowerFlex 700 Variable Frequency AC Drive (VFD) Units with Circuit Breaker Disconnect, 600VAC (HEAVY DUTY)

- See page 145 for product description.
- Heavy Duty Ratings, the drive overload capabilities (based on the output currents listed below) are: 150% for 60 seconds and 200% for 3 seconds.
- For specific drive applications refer to the PowerFlex 700 User Manual.
- Branch circuit (overload) protection is provided by the internal drive overload.
- PowerFlex 700 drives are cUL US (UL and cUL listed) as motor overload protected devices. An external overload relay is not required for single motor applications. PowerFlex 700 AC drives are not intended for use with single phase motors.
- See page 238 for Combination Unit Short Circuit Withstand Ratings table.
- Wiring is Type A only. Drive can accept 16 AWG control wire maximum.
- Proper placement of drive units in the MCC is essential for proper operation and life cycle of the drive. Strong consideration should be given to placing units with drives at the bottom of the section. When more than one drive unit is placed in a section, the drive unit with the highest rating should be located at the bottom of the section.
- Do not mount transformer units below drive units. Heat from transformer units may cause drive to trip.
- HIM (Human Interface Module) and Control Interface Type are required. Select on page 189 and 190.

228

Frame	Maximum Continuous Output Amperes	Nominal HP	NEMA Type 1 and Type 1 w/ gasket		NEMA Type 12		Delivery Program
		The HP ratings shown below are for reference only. PowerFlex 700 drive units should be sized according to the application and output ampere rating.	Space Factor	Catalog Number <sup>[1]</sup>	Space Factor	Catalog Number <sup>[1]</sup>	
0	1.7 <sup>[2]</sup>	1	2.0	2163RA-2P7HKC-35_	2.0	2163RA-2P7HJC-35_	PE in U.S., SC in Canada
	2.4 <sup>[2]</sup>	1.5		2163RA-2P7HKC-36_		2163RA-2P7HJC-36_	
	2.7 <sup>[2]</sup>	2		2163RA-3P9HKC-37_		2163RA-3P9HJC-37_	
	3.9 <sup>[2]</sup>	3		2163RA-6P1HKC-38_	2.5	2163RA-6P1HJC-38_	
	6.1 <sup>[2]</sup>	5		2163RA-9P0HKC-39_		2163RA-9P0HJC-39_	
1	9.0 <sup>[2]</sup>	7.5	2163RA-011HKC-40_	3.0	2163RA-011HJC-40_		
	11 <sup>[2]</sup>	10	2163RA-017HKC-41_		2163RA-017HJC-41_		
2	17 <sup>[2]</sup>	15	2163RA-022HKC-42_	3.5	2163RA-022HJC-42_		
	22 <sup>[2]</sup>	20	2163RA-027HKC-43_		2163RA-027HJC-43_		
3	27 <sup>[2]</sup>	25	2163RA-032HKC-44_	4.0	2163RA-032HJC-44_		
	32 <sup>[2]</sup>	30	2163RA-041HKC-45_		2163RA-041HJC-45_		
	41 <sup>[2]</sup>	40	2163RA-052HKC-46_	2163RA-052HJC-46_			
4	52 <sup>[3]</sup>	50	6.0, 20"W <sup>[4]</sup>	2163RA-062HKC-47_	6.0, 25"W <sup>[4]</sup>	2163RA-062HJC-47_	
5	62 <sup>[3]</sup>	60	6.0, 25"W, 20"D <sup>[5]</sup>	2163RA-077HKC-48_	6.0, 25"W, 20"D <sup>[5]</sup>	2163RA-077HJC-48_	
6	77 <sup>[3]</sup>	75		2163RA-125HKC-49_	6.0,	2163RA-125HJC-49_	
	99 <sup>[3]</sup>	100		2163RA-125HKC-50_	30"W, 20"D <sup>[5]</sup>	2163RA-125HJC-50_	
	125 <sup>[3]</sup>	125		2163RA-144HKC-51_	6.0, 35"W, 20"D <sup>[5]</sup>	2163RA-144HJC-51_	

[1] The catalog numbers listed are not complete:

- Select the appropriate suffix from table on page 212 to identify the circuit breaker type (e.g. 2163RA-032HKC-44**CA**).
- [2] Ampere ratings are at a 4kHz carrier frequency. If carrier frequencies above 4kHz are selected, the drive output current ratings **must** be derated. For derating information, contact your local Rockwell Automation Sales Office and/or refer to *PowerFlex 70/700 Reference Manual*, PFLEX-RM001x-EN-E.
- [3] Ampere ratings are at 2kHz carrier frequency. If carrier frequencies above 2kHz are selected, the drive output current ratings **may** require derating. Contact your local Rockwell Automation Sales Office and to *PowerFlex 70/700 Reference Manual*, PFLEX-RM001x-EN-E.
- [4] Frame mounted unit, section does not have vertical wireway.
- [5] Frame mounted unit, section does not have vertical wireway. Horizontal bus is 5" deeper than standard.

**Catalog Number Explanation - Bulletin 2162T and 2163T PowerFlex 40 Drive**

- Bulletins 2162T and 2163T use PowerFlex 40 Drives
- Bulletins 2162T and 2163T are sized for Normal Duty applications
- NEMA Enclosure Type 1, Type 1 with gasket or Type 12 Enclosure Type
- UL Class CC or J time delay drive input fuses provide both branch circuit and drive input protection, fuse class dependent on drive rating
- Isolated logic and power produces a three-phase, pulse-width-modulated (PWM) adjustable frequency output to vary motor speed

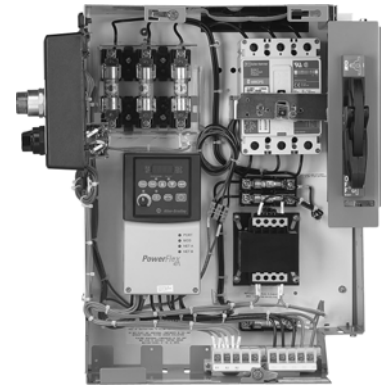

229

<b>2162T</b>	<b>A</b>	-	<b>6P0</b>	<b>K</b>	<b>B</b>	-	<b>38</b>	-	<b>14HBA3</b>
<b>2163T</b>	<b>A</b>	-	<b>6P0</b>	<b>K</b>	<b>B</b>	-	<b>38CA</b>	-	<b>14HBA3</b>
<i>Bulletin Number</i>	<i>Wiring Type</i>		<i>PowerFlex 40 Nominal Output Current Rating</i>	<i>NEMA Enclosure Type</i>	<i>Line Voltage</i>		<i>Nominal Horsepower/kW and Circuit Breaker Type</i>		<i>Human Interface Module and Options</i>

229A

Code	Type
2162T	PowerFlex 40 Variable Frequency AC Drive with Fusible Disconnect
2163T	PowerFlex 40 Variable Frequency AC Drive with Circuit Breaker

229D

Code	NEMA Enclosure Type
K	NEMA Type 1 or Type 1 with gasket
J	NEMA Type 12

229F

Code	Nominal Horsepower/kW Code and Circuit Breaker Type
2162T-"38"	"38" Nominal Horsepower/kW code. See table on page 206
2163T-"38CA"	"38_" Nominal Horsepower/kW code. See table on page 206 "__CA" Circuit Breaker Type. See table on page 212

229B

Code	Wiring Type
A	Type A

229C

Nominal Constant Current Ratings (Amperes)			
380-480V Line Voltage		600V Line Voltage	
Code	Ratings	Code	Ratings
1P4	1.4	1P7	1.7
2P3	2.3	3P0	3.0
4P0	4.0	4P2	4.2
6P0	6.0	6P6	6.6
010	10.5	9P9	9.9
012	12	012	12.2
017	17	019	19
024	24		

229E

Code	Line Voltage
N	380V <sup>[1]</sup>
KN	400V <sup>[1]</sup>
I	415V <sup>[1]</sup>
B	480V
C	600V

[1] Units at these voltages are not UL or cUL listed.

229G

Code	Human Interface Module and Options
	See options section beginning on page 187

## Variable Frequency AC Motor Drive Units

### Units—2162T

#### Combination PowerFlex 40 Variable Frequency AC Drive (VFD) Units with Fusible Disconnect, 380-480VAC

- See page 146 for product description.
- For specific drive applications refer to PowerFlex 40 User Manual.
- All PowerFlex ratings are **Normal Duty**.
- Branch circuit (overload) protection is provided by the internal drive overload.
- See page 238 for Combination Unit Short Circuit Withstand Ratings table.
- Wiring is Type A only. Drive can only accept 16 AWG control wire.
- Proper placement of drive units in the MCC is essential for proper operation and life cycle of the drive. Strong consideration should be given to placing units with drives at the bottom of the section. When more than one drive unit is placed in a section, the drive unit with the highest rating should be located at the bottom of the section.
- Do not mount transformer units below drive units. Heat from transformer units may cause drive to trip.
- Internal HIM (Human Interface Module) is included. Optional door mounted HIMs can be selected on page 189.
- PowerFlex 40 AC drives are cUL US (UL and cUL listed) as motor overload protective devices. An external overload relay is not required for single motor applications. PowerFlex 40 AC drives are not intended for use with single phase motors.

230

Frame	Maximum Continuous Output Amperes <sup>[1]</sup>	Nominal kW	Nominal HP	NEMA Type 1 and Type 1 w/ gasket		NEMA 12		Delivery Program
		The horsepower and kw ratings shown below are for reference only. PowerFlex 40 drive units should be sized according to the application and output ampere rating.		Space Factor	Catalog Number <sup>[2]</sup>	Space Factor	Catalog Number <sup>[2]</sup>	
		380-415V <sup>[3]</sup>	480V					
B	1.4	0.37	0.5	1.0 <sup>[4]</sup>	2162TA-1P4K_ _	1.5 <sup>[4]</sup>	2162TA-1P4J_ _	SC
	2.3	0.55 - 0.75	0.75 - 1.0		2162TA-2P3K_ _		2162TA-2P3J_ _	
	4.0	1.1 - 1.5	2.0		2162TA-4P0K_ _		2162TA-4P0J_ _	
	6.0	2.2	3.0		2162TA-6P0K_ _		2162TA-6P0J_ _	
	10.5	3.7	5.0		2162TA-010K_ _		2162TA-010J_ _	
C	12	5.5	7.5	2.0 <sup>[4]</sup>	2162TA-012K_ _	2.5 <sup>[4]</sup>	2162TA-012J_ _	SC
	17	7.5	10		2162TA-017K_ _		2162TA-017J_ _	
	24	11	15		2162TA-024K_ _		2162TA-024J_ _	

[1] Ampere ratings are at a 4kHz carrier frequency. If carrier frequencies above 4kHz are selected, the drive output current ratings **must** be derated. For derating information, contact your local Rockwell Automation Sales Office and/or refer to *PowerFlex 40 User Manual*, 22B-UM001x-EN-E.

[2] The catalog numbers listed are not complete:

- Select voltage code from table on page 206 to the horsepower rating desired (e.g., 2162TA-1P4KB).
- Select the number from table on page 206 that corresponds to the horsepower or kilowatt rating desired (e.g., 2162TA-1P4KB-33 or 2162TA-1P4KN-33K).

[3] Units at these voltages are not UL listed or cUL listed

[4] Adding options to this catalog number could result in an increased space factor.

14

#### PowerFlex 40 Space Factors with Options

231

Voltage Rating	Frame	Drive Rating	NEMA 1/1G					NEMA 12				
			Base Unit (Space Factor)	Control Station (-1, 3, 4 or 5)	Isolated Signal Conditioner (-14N2)	Line or Load Reactors (-14R_ _)	Isolated Signal Conditioner (-14N2) AND Line or Load Reactors	Base Unit (Space Factor)	Control Station (-1, 3, 4 or 5)	Isolated Signal Conditioner (-14N2)	Line or Load Reactors (-14R_ _)	Isolated Signal Conditioner (-14N2) AND Line or Load Reactors
380, 400, 415	B	1.4A	1.0	1.5	1.5	N/A	N/A	1.5	1.5	1.5	N/A	N/A
		2.3A										
		4.0A										
		6.0A										
		10.5A										
	C	12A	2.0	2.0	2.0	N/A	N/A	2.5	2.5	2.5	N/A	N/A
17A												
24A												
480	B	1.4A	1.0	1.5	1.5	1.5	1.5	1.5	1.5	1.5	2.0	2.0
		2.3A										
		4.0A										
		6.0A										
		10.5A										
	C	12A	2.0	2.0	2.0	2.0	2.0	2.5	2.5	2.5	2.5	2.5
17A												
24A												

Combination PowerFlex 40 Variable Frequency AC Drive (VFD) Units with Fusible Disconnect, 600VAC

- See page 146 for product description.
- For specific drive applications refer to PowerFlex 40 User Manual.
- All PowerFlex ratings are **Normal Duty**.
- Branch circuit (overload) protection is provided by the internal drive overload.
- See page 238 for Combination Unit Short Circuit Withstand Ratings table.
- Wiring is Type A only. Drive can only accept 16 AWG control wire.
- Proper placement of drive units in the MCC is essential for proper operation and life cycle of the drive. Strong consideration should be given to placing units with drives at the bottom of the section. When more than one drive unit is placed in a section, the drive unit with the highest rating should be located at the bottom of the section.
- Do not mount transformer units below drive units. Heat from transformer units may cause drive to trip.
- Internal HIM (Human Interface Module) is included. Optional door mounted HIMs can be selected on page 189.
- PowerFlex 40 AC drives are cUL US (UL and cUL listed) as motor overload protective devices. An external overload relay is not required for single motor applications. PowerFlex 40 AC drives are not intended for use with single phase motors.

232

Frame	Maximum Continuous Output Amperes <sup>[1]</sup>	Nominal HP	NEMA Type 1 and Type 1 w/ gasket		NEMA 12		Delivery Program
		The HP ratings shown below are for reference only. PowerFlex 40 drive units should be sized according to the application and output ampere rating.	Space Factor	Catalog Number t <sup>[2]</sup>	Space Factor	Catalog Number <sup>[2]</sup>	
B	1.7	1.0	1.0 <sup>[3]</sup>	2162TA-1P7K_ _	1.5 <sup>[3]</sup>	2162TA-1P7J_ _	PE in U.S.,
	3.0	1.5 - 2.0		2162TA-3P0K_ _		2162TA-3P0J_ _	
	4.2	3.0		2162TA-4P2K_ _		2162TA-4P2J_ _	
	6.6	5.0		2162TA-6P6K_ _	2.0 <sup>[3]</sup>	2162TA-6P6J_ _	
C	9.9	7.5	2.0 <sup>[3]</sup>	2162TA-9P9K_ _	2.5 <sup>[3]</sup>	2162TA-9P9J_ _	SC in Canada
	12.2	10		2162TA-012K_ _		2162TA-012J_ _	
	19.0	15		2162TA-019K_ _	3.0 <sup>[3]</sup>	2162TA-019J_ _	

[1] Ampere ratings are at a 4kHz carrier frequency. If carrier frequencies above 4kHz are selected, the drive output current ratings **must** be derated. For derating information, contact your local Rockwell Automation Sales Office and/or refer to *PowerFlex 40 User Manual*, 22B-UM001x-EN-E.

[2] The catalog numbers listed are not complete.

- Select voltage code from table on page 206 to the horsepower rating desired (e.g., 2162TA-1P7K**C**).
- Select the number from table on page 206 that corresponds to the horsepower rating desired (e.g., 2162TA-1P7K**C-35**).

[3] Adding options to this catalog number could result in an increased space factor.

PowerFlex 40 Space Factors with Options

233

Voltage Rating	Frame	Drive Rating	NEMA 1/1G					NEMA 12				
			Base Unit (Space Factor)	Control Station (-1, 3, 4 or 5)	Isolated Signal Conditioner (-14N2)	Line or Load Reactors (-14R_ _)	Isolated Signal Conditioner (-14N2) AND Line or Load Reactors	Base Unit (Space Factor)	Control Station (-1, 3, 4 or 5)	Isolated Signal Conditioner (-14N2)	Line or Load Reactors (-14R_ _)	Isolated Signal Conditioner (-14N2) AND Line or Load Reactors
600	B	1.7A	1.0	1.5	1.5	1.5	1.5	1.5	1.5	1.5	2.0	2.0
		3.0A										
		4.2A										
		6.6A					2.0	2.0	2.0	2.0	2.0	2.5
	9.9A											
	C	12.2A	2.0	2.0	2.0	2.0	2.0	2.5	2.5	2.5	2.5	2.5
19A		3.0						3.0	3.0	3.0	3.0	

## Variable Frequency AC Motor Drive Units

### Units—2163T

#### Combination PowerFlex 40 Variable Frequency AC Drive (VFD) Units with Circuit Breaker, 380-480VAC

- See page 146 for product description.
- For specific drive applications refer to PowerFlex 40 User Manual.
- All PowerFlex ratings are **Normal Duty**.
- Branch circuit (overload) protection is provided by the internal drive overload.
- See page 238 for Combination Unit Short Circuit Withstand Ratings table.
- Wiring is Type A only. Drive can only accept 16 AWG control wire.
- Proper placement of drive units in the MCC is essential for proper operation and life cycle of the drive. Strong consideration should be given to placing units with drives at the bottom of the section. When more than one drive unit is placed in a section, the drive unit with the highest rating should be located at the bottom of the section.
- Do not mount transformer units below drive units. Heat from transformer units may cause drive to trip.
- Internal HIM (Human Interface Module) is included. Optional door mounted HIMs can be selected on page 189.
- PowerFlex 40 AC drives are cUL US (UL and cUL listed) as motor overload protective devices. An external overload relay is not required for single motor applications. PowerFlex 40 AC drives are not intended for use with single phase motors.

234

Frame	Maximum Continuous Output Amperes <sup>[1]</sup>	Nominal kW		Nominal HP		NEMA Type 1 and Type 1 w/ gasket		NEMA 12		Delivery Program				
		The HP and kW ratings shown below are for reference only. PowerFlex 40 drive units should be sized according to the application and output ampere rating.				Space Factor	Catalog Number t <sup>[2]</sup>	Space Factor	Catalog Number <sup>[2]</sup>					
		380-415V <sup>[3]</sup>		480V										
B	1.4	0.37		0.5		1.0 <sup>[4]</sup>	2163TA-1P4K_ _	1.5 <sup>[4]</sup>	2163TA-1P4J_ _	SC				
	2.3	0.55 - 0.75		0.75 - 1.0							2163TA-2P3K_ _	2163TA-2P3J_ _		
	4.0	1.1 - 1.5		1.5 - 2.0									2163TA-4P0K_ _	2163TA-4P0J_ _
	6.0	2.2		3.0										
	10.5	3.7		5.0									2.0 <sup>[4]</sup>	2163TA-010K_ _
C	12	5.5		7.5		2.0 <sup>[4]</sup>	2163TA-012K_ _	2.5 <sup>[4]</sup>	2163TA-012J_ _					
	17	7.5		10						2163TA-017K_ _	2163TA-017J_ _			
	24	11		15								3.0 <sup>[4]</sup>	2163TA-024K_ _	2163TA-024J_ _

[1] Ampere ratings are at a 4kHz carrier frequency. If carrier frequencies above 4kHz are selected, the drive output current ratings **must** be derated. For derating information, contact your local Rockwell Automation Sales Office and/or refer to *PowerFlex 40 User Manual*, 22B-UM001x-EN-E.

[2] The catalog numbers listed are not complete:

- Select voltage code from table on page 206 to the horsepower rating desired (e.g., 2163TA-1P4KB).
- Select the number from table on page 206 that corresponds to the horsepower rating desired (e.g., 2163TA-1P4KB-**33**).
- Select the appropriate suffix from table on page 212 to identify the circuit breaker type (e.g., 2163TA-1P4KB-**33CA**).

[3] Units at these voltages are not UL listed or cUL listed.

[4] Adding options to this catalog number could result in an increased space factor.

14

### PowerFlex 40 Space Factors with Options

235

Voltage Rating	Frame	Drive Rating	NEMA 1/1G					NEMA 12				
			Base Unit (Space Factor)	Control Station (-1, 3, 4 or 5)	Isolated Signal Conditioner (-14N2)	Line or Load Reactors (-14R_ _)	Isolated Signal Conditioner (-14N2) AND Line or Load Reactors	Base Unit (Space Factor)	Control Station (-1, 3, 4 or 5)	Isolated Signal Conditioner (-14N2)	Line or Load Reactors (-14R_ _)	Isolated Signal Conditioner (-14N2) AND Line or Load Reactors
380, 400, 415	B	1.4A	1.0	1.5	1.5	N/A	N/A	1.5	1.5	1.5	N/A	N/A
		2.3A										
		4.0A										
		6.0A										
		10.5A										
	C	12A	2.0	2.0	2.0	N/A	N/A	2.5	2.5	2.5	N/A	N/A
17A												
24A												
480	B	1.4A	1.0	1.5	1.5	1.5	1.5	1.5	1.5	1.5	2.0	2.0
		2.3A										
		4.0A										
		6.0A										
		10.5A										
	C	12A	2.0	2.0	2.0	2.0	2.0	2.5	2.5	2.5	2.5	2.5
17A												
24A												

Combination PowerFlex 40 Variable Frequency AC Drive (VFD) Units with Fusible Disconnect, 600VAC

- See page 146 for product description.
- For specific drive applications refer to PowerFlex 40 User Manual.
- All PowerFlex ratings are **Normal Duty**.
- Branch circuit (overload) protection is provided by the internal drive overload.
- See page 238 for Combination Unit Short Circuit Withstand Ratings table.
- Wiring is Type A only. Drive can only accept 16 AWG control wire.
- Proper placement of drive units in the MCC is essential for proper operation and life cycle of the drive. Strong consideration should be given to placing units with drives at the bottom of the section. When more than one drive unit is placed in a section, the drive unit with the highest rating should be located at the bottom of the section.
- Do not mount transformer units below drive units. Heat from transformer units may cause drive to trip.
- Internal HIM (Human Interface Module) is included. Optional door mounted HIMs can be selected on page 189.
- PowerFlex 40 AC drives are cUL US (UL and cUL listed) as motor overload protective devices. An external overload relay is not required for single motor applications. PowerFlex 40 AC drives are not intended for use with single phase motors.

236

Frame	Maximum Continuous Output Amperes <sup>[1]</sup>	Nominal HP <small>The HP ratings shown below are for reference only. PowerFlex 40 drive units should be sized according to the application and output ampere rating.</small>	NEMA Type 1 and Type 1 w/ gasket		NEMA 12		Delivery Program
			Space Factor	Catalog Number <sup>t</sup> [2]	Space Factor	Catalog Number [2]	
B	1.7	1.0	1.0 [3]	2163TA-1P7K_ _	1.5 [3]	2163TA-1P7J_ _	PE in U.S.,  SC in Canada
	3.0	1.5 - 2.0		2163TA-3P0K_ _		2163TA-3P0J_ _	
	4.2	3.0		2163TA-4P2K_ _		2163TA-4P2J_ _	
	6.6	5.0		2163TA-6P6K_ _	2.0 [3]	2163TA-6P6J_ _	
C	9.9	7.5	2.0 [3]	2163TA-9P9K_ _	2.5 [3]	2163TA-9P9J_ _	
	12.2	10		2163TA-012K_ _		2163TA-012J_ _	
	19.0	15		2163TA-019K_ _	3.0 [3]	2163TA-019J_ _	

[1] Ampere ratings are at a 4kHz carrier frequency. If carrier frequencies above 4kHz are selected, the drive output current ratings **must** be derated. For derating information, contact your local Rockwell Automation Sales Office and/or refer to *PowerFlex 40 User Manual*, 22B-UM001x-EN-E.

[2] The catalog numbers listed are not complete:  
 • Select voltage code from table on page 206 to the horsepower rating desired (e.g., 2163TA-1P7K**C**).  
 • Select the number from table on page 206 that corresponds to the horsepower rating desired (e.g., 2163TA-1P7K**C-35**).  
 • Select the appropriate suffix from table on page 212 to identify the circuit breaker type (e.g., 2163TA-1P4KB-33**CA**).

[3] Adding options to this catalog number could result in an increased space factor.

PowerFlex 40 Space Factors with Options

237

Voltage Rating	Frame	Drive Rating	NEMA 1/1G					NEMA 12				
			Base Unit (Space Factor)	Control Station (-1, 3, 4 or 5)	Isolated Signal Conditioner (-14N2)	Line or Load Reactors (-14R_ _)	Isolated Signal Conditioner (-14N2) AND Line or Load Reactors	Base Unit (Space Factor)	Control Station (-1, 3, 4 or 5)	Isolated Signal Conditioner (-14N2)	Line or Load Reactors (-14R_ _)	Isolated Signal Conditioner (-14N2) AND Line or Load Reactors
600	B	1.7A	1.0	1.5	1.5	1.5	1.5	1.5	1.5	1.5	2.0	2.0
		3.0A										
		4.2A										
		6.6A										
	C	9.9A	2.0	2.0	2.0	2.0	2.0	2.5	2.5	2.5	2.5	2.5
		12.2A						3.0	3.0	3.0	3.0	3.0
		19A										

## Variable Frequency AC Motor Drive Units

### Catalog Number Explanation - Bulletin 2164Q and 2165Q

#### PowerFlex 70 Drive with Manual Isolated Drive Bypass

- Bulletins 2164Q and 2165Q use **Normal Duty** PowerFlex 70 Drives
- Two interlocked compartments, one with bypass circuitry and one with drive - drive can be taken offline and replaced as needed with minimal disruption to the application process
- NEMA Enclosure Type 1, Type 1 with gasket or Type 12 Enclosure Type
- NEMA Wiring Class I, Type A
- Isolated logic and power produces a three-phase, pulse-width-modulated (PWM) adjustable frequency output to vary motor speed

238

<b>2164Q</b>	<b>A</b>	-	<b>1P1</b>	<b>A</b>	<b>B</b>	-	<b>33</b>	-	<b>14HA0</b>
<b>2165Q</b>	<b>A</b>	-	<b>1P1</b>	<b>A</b>	<b>B</b>	-	<b>33CA</b>	-	<b>14HA0</b>
<i>Bulletin Number</i>	<i>Wiring Type</i>		<i>PowerFlex 70 Nominal Output Current Rating</i>	<i>NEMA Enclosure Type</i>	<i>Line Voltage</i>		<i>Nominal Horsepower/kW and Circuit Breaker Type</i>		<i>Human Interface Module and Options</i>

238A

Code	Type
2164Q	Manual Drive Bypass with PowerFlex 70 VFD and Fusible Disconnect
2165Q	Manual Drive Bypass with PowerFlex 70 VFD and Circuit Breaker

238B

Code	Wiring Type
A	Type A

238D

Code	NEMA Enclosure Type
A	NEMA Type 1 or Type 1 with gasket w/ external reset button
K	NEMA Type 1 or Type 1 with gasket w/o external reset button
D	NEMA Type 12 w/ external reset button
J	NEMA Type 12 w/o external reset button

238C

Nominal Constant Current Ratings (Amperes) [1]			
480 Line Voltage		600V Line Voltage	
Code	Ratings	Code	Ratings
1P1	1.1	0P9	0.9
2P1	2.1	1P7	1.7
3P4	3.4	2P7	2.7
5P0	5.0	3P9	3.9
8P0	8	6P1	6.1
011	11	9P0	9.0
014	14	011	11
022	22	017	17
027	27	022	22

[1] Bulletins 2164Q and 2165Q use Normal Duty PowerFlex 70 Drives.

238E

Code	Line Voltage
B	480V
C	600V

238F

Code	Nominal Horsepower/kW Code and Circuit Breaker Type
2164Q-"33"	"33" Nominal Horsepower/kW code. See table on page 206
2165Q-"33CA"	"33_" Nominal Horsepower/kW code. See table on page 206 " _CA" Circuit Breaker Type. See table on page 212

238G

Code	Human Interface Module and Options
	See options section beginning on page 187

Combination PowerFlex 70 Variable Frequency AC Drive (VFD) with Fusible Disconnect and Manual, Isolated Bypass, 480V

- See page 146 for product description.
- All PowerFlex ratings are **Normal Duty**.
- Proper placement of drive units in the MCC is essential for proper operation and life cycle of the drive. Strong consideration should be given to placing units with drives at the bottom of the section. When more than one drive unit is placed in a section, the drive unit with the highest rating should be located at the bottom of the section.
- See page 238 for Combination Unit Short Circuit Withstand Ratings table.
- Configuration consists of two units. The bypass unit contains a fusible disconnect, bypass contactor, 6-pole manual bypass switch, control circuit transformer and pull-apart terminal blocks. Drive unit contains PowerFlex 70 variable frequency drive.
- A Human Interface Module and Control Platform Type are **required**. Select on page 189 and 190.
- “DRIVE ON” and “BYPASS ON” pilot lights (options 4\_ \_) and HAND-OFF-AUTO/HAND START-HAND STOP (option 1F) must be specified. See page 187.
- Unit doors are interlocked.

239

Frame	Maximum Continuous Output Amperes [1]	Nominal HP	NEMA Type 1 and Type 1 w/ gasket		NEMA 12		Delivery Program	
		The horsepower ratings shown below are for reference only. PowerFlex 70 drive units should be sized according to the application and output ampere rating.	Space Factor	Catalog Number [2]	Space Factor	Catalog Number [2]		
A	1.1	0.5	2.5	2164QA-1P1A_ _	3.0	2164QA-1P1D_ _	SC-II	
	2.1	0.75-1		2164QA-2P1A_ _		2164QA-2P1D_ _		
	3.4	1.5-2		2164QA-3P4A_ _		2164QA-3P4D_ _		
B	5	3	3.0	2164QA-5P0A_ _	3.5	2164QA-5P0D_ _		
	8	5		2164QA-8P0A_ _		2164QA-8P0D_ _		
C	11	7.5	3.5	2164QA-011A_ _	4.0	2164QA-011D_ _		
	14	10		2164QA-014A_ _		2164QA-014D_ _		
D	22	15		4.5	2164QA-022A_ _	4.5		2164QA-022D_ _
	27	20			2164QA-027A_ _			2164QA-027D_ _

[1] Ampere ratings are at a 4kHz carrier frequency. If carrier frequencies above 4kHz are selected, the drive output ampere ratings **must** be derated. For derating information, contact your local Rockwell Automation Sales Office and/or refer to *PowerFlex 70/700 Reference Manual*, PFLEX-RM001x-EN-E.

[2] The catalog numbers listed are not complete:

- Select voltage code from table on page 206 (2164QA-1P1A**B**\_ \_).
- Select HP rating code from table on page 206 that corresponds to the nominal horsepower rating desired (e.g., 2164QA-1P1A**B-33**).
- The catalog numbers listed include an external reset button for the overload relay. To order catalog numbers **without** the external reset button, replace the letter “A” with the letter “K” (e.g., 2164QA-1P1**K**\_ \_) or replace the letter “D” with the letter “J” (e.g., 2164QA-1P1**J**\_ \_).

## Variable Frequency AC Motor Drive Units

### Units—2164Q

#### Combination PowerFlex 70 Variable Frequency AC Drive (VFD) with Fusible Disconnect and Manual, Isolated Bypass, 600V

- See page 146 for product description.
- All PowerFlex ratings are **Normal Duty**.
- Proper placement of drive units in the MCC is essential for proper operation and life cycle of the drive. Strong consideration should be given to placing units with drives at the bottom of the section. When more than one drive unit is placed in a section, the drive unit with the highest rating should be located at the bottom of the section.
- See page 238 for Combination Unit Short Circuit Withstand Ratings table.
- Configuration consists of two units. The bypass unit contains a fusible disconnect, bypass contactor, 6-pole manual bypass switch, control circuit transformer and pull-apart terminal blocks. Drive unit contains PowerFlex 70 variable frequency drive.
- A Human Interface Module and Control Platform Type are **required**. Select on page 189 and 190.
- “DRIVE ON” and “BYPASS ON” pilot lights (options 4\_ \_) and HAND-OFF-AUTO/HAND START-HAND STOP (option 1F) must be specified. See page 187.
- Unit doors are interlocked.

240

Frame	Maximum Continuous Output Amperes [1]	Nominal HP	NEMA Type 1 and Type 1 w/ gasket		NEMA 12		Delivery Program
		The horsepower ratings shown below are for reference only. PowerFlex 70 drive units should be sized according to the application and output ampere rating.	Space Factor	Catalog Number [2]	Space Factor	Catalog Number [2]	
A	0.9	0.5	2.5	2164QA-0P9A_ _	3.0	2164QA-0P9D_ _	PE-II in U.S SC-II in Canada
	1.7	0.75-1		2164QA-1P7A_ _		2164QA-1P7D_ _	
	2.7	1.5-2		2164QA-2P7A_ _		2164QA-2P7D_ _	
B	3.9	3	3.0	2164QA-3P9A_ _	3.5	2164QA-3P9D_ _	
	6.1	5		2164QA-6P1A_ _		2164QA-6P1D_ _	
C	9	7.5	3.5	2164QA-9P0A_ _	4.0	2164QA-9P0D_ _	
	11	10		2164QA-011A_ _		2164QA-011D_ _	
D	17	15		4.5	2164QA-017A_ _	4.5	2164QA-017D_ _
	22	20			2164QA-022A_ _		2164QA-022D_ _

[1] Ampere ratings are at a 4kHz carrier frequency. If carrier frequencies above 4kHz are selected, the drive output ampere ratings **must** be derated. For derating information, contact your local Rockwell Automation Sales Office and/or refer to *PowerFlex 70/700 Reference Manual*, PFLEX-RM001x-EN-E.

[2] The catalog numbers listed are not complete:

- Select voltage code from table on page 206 (2164QA-1P7A**C**\_ \_).
- Select HP rating code from table on page 206 that corresponds to the nominal horsepower rating desired (e.g., 2164QA-1P7A**C34**).
- The catalog numbers listed include an external reset button for the overload relay. To order catalog numbers **without** the external reset button, replace the letter “A” with the letter “K” (e.g., 2164QA-1P7**K**\_ \_) or replace the letter “D” with the letter “J” (e.g., 2164QA-1P7**J**\_ \_).

Combination PowerFlex 70 Variable Frequency AC Drive (VFD) with Circuit Breaker Disconnect and Manual, Isolated Bypass, 480V

- See page 146 for product description.
- All PowerFlex ratings are **Normal Duty**.
- Proper placement of drive units in the MCC is essential for proper operation and life cycle of the drive. Strong consideration should be given to placing units with drives at the bottom of the section. When more than one drive unit is placed in a section, the drive unit with the highest rating should be located at the bottom of the section.
- See page 238 for Combination Unit Short Circuit Withstand Ratings table.
- Configuration consists of two units. The bypass unit contains a circuit breaker, bypass contactor, 6-pole manual bypass switch, control circuit transformer and pull-apart terminal blocks. Drive unit contains PowerFlex 70 variable frequency drive and pull-apart terminal blocks.
- A Human Interface Module and Control Platform Type are **required**. Select on page 189 and 190.
- “DRIVE ON” and “BYPASS ON” pilot lights (options 4\_ \_) and HAND-OFF-AUTO/HAND START-HAND STOP (option 1F) must be specified. See page 187.
- Unit doors are interlocked.

241

Frame	Maximum Continuous Output Amperes [1]	Nominal HP	NEMA Type 1 and Type 1 w/ gasket		NEMA 12		Delivery Program	
		The horsepower ratings shown below are for reference only. PowerFlex 70 AC drive units should be sized according to the application and output ampere rating.	Space Factor	Catalog Number [2]	Space Factor	Catalog Number [2]		
A	1.1	0.5	2.5	2165QA-1P1A_ _	3.0	2165QA-1P1D_ _	SC-II	
	2.1	0.75-1		2165QA-2P1A_ _		2165QA-2P1D_ _		
	3.4	1.5-2		2165QA-3P4A_ _		2165QA-3P4D_ _		
B	5	3	3.0	2165QA-5P0A_ _	3.5	2165QA-5P0D_ _		
	8	5		2165QA-8P0A_ _		2165QA-8P0D_ _		
C	11	7.5	3.5	2165QA-011A_ _	4.0	2165QA-011D_ _		
	14	10		2165QA-014A_ _		2165QA-014D_ _		
D	22	15		4.5	2165QA-022A_ _	4.5		2165QA-022D_ _
	27	20			2165QA-027A_ _			2165QA-027D_ _

[1] Ampere ratings are at a 4kHz carrier frequency. If carrier frequencies above 4kHz are selected, the drive output ampere ratings **must** be derated. For derating information, contact your local Rockwell Automation Sales Office and/or refer to *PowerFlex 70/700 Reference Manual*, PFLEX-RM001x-EN-E.

[2] The catalog numbers listed are not complete:

- Select voltage code from table on page 206 (e.g., 2165QA-1P1A**AB**).
- Select HP rating code from table on page 206 that corresponds to the nominal horsepower rating desired (e.g., 2165QA-1P1A**B-33**).
- Select the appropriate suffix from the Circuit Breaker Type table on page 212 to identify circuit breaker type (e.g., 2165QA-1P1A**B-33CA**).
- The catalog numbers listed include an external reset button for the overload relay. To order catalog numbers **without** the external reset button, replace the letter “A” with the letter “K” (e.g., 2165QA-1P1**K**\_ \_) or replace the letter “D” with the letter “J” (e.g., 2165QA-1P1**J**\_ \_).

## Variable Frequency AC Motor Drive Units

### Units—2165Q

Combination PowerFlex 70 Variable Frequency AC Drive (VFD) with Circuit Breaker Disconnect and Manual, Isolated Bypass, 600V

- See page 146 for product description.
- All PowerFlex ratings are **Normal Duty**.
- Proper placement of drive units in the MCC is essential for proper operation and life cycle of the drive. Strong consideration should be given to placing units with drives at the bottom of the section. When more than one drive unit is placed in a section, the drive unit with the highest rating should be located at the bottom of the section.
- See page 238 for Combination Unit Short Circuit Withstand Ratings table.
- Configuration consists of two units. The bypass unit contains a circuit breaker, bypass contactor, 6-pole manual bypass switch, control circuit transformer and pull-apart terminal blocks. Drive unit contains PowerFlex 70 variable frequency drive and pull-apart terminal blocks.
- A Human Interface Module and Control Platform Type are **required**. Select on page 189 and 190.
- “DRIVE ON” and “BYPASS ON” pilot lights (options 4\_ \_) and HAND-OFF-AUTO/HAND START-HAND STOP (option 1F) must be specified. See page 187.
- Unit doors are interlocked.

242

Frame	Maximum Continuous Output Amperes [1]	Nominal HP	Space Factor	Catalog Number NEMA Type 1 and Type 1 w/ gasket [2]	Space Factor	Catalog Number NEMA 12 [2]	Delivery Program
		The horsepower ratings shown below are for reference only. PowerFlex 70 AC drive units should be sized according to the application and output ampere rating.					
A	0.9	0.5	2.5	2165QA-0P9A _ _	3.0	2165QA-0P9D _ _	PE-II in U.S. SC-II in Canada
	1.7	0.75-1		2165QA-1P7A _ _		2165QA-1P7D _ _	
	2.7	1.5-2		2165QA-2P7A _ _		2165QA-2P7D _ _	
B	3.9	3	2165QA-3P9A _ _	2165QA-3P9D _ _			
	6.1	5	2165QA-6P1A _ _	2165QA-6P1D _ _			
C	9	7.5	2165QA-9P0A _ _	2165QA-9P0D _ _			
	11	10	2165QA-011A _ _	2165QA-011D _ _			
D	17	15	2165QA-017A _ _	2165QA-017D _ _			
	22	20	2165QA-022A _ _	2165QA-022D _ _			

[1] Ampere ratings are at a 4kHz carrier frequency. If carrier frequencies above 4kHz are selected, the drive output ampere ratings **must** be derated. For derating information, contact your local Rockwell Automation Sales Office and/or refer to *PowerFlex 70/700 Reference Manual*, PFLEX-RM001x-EN-E.

[2] The catalog numbers listed are not complete:

- Select voltage code from table on page 206 (e.g., 2165QA-1P7**AC**).
- Select HP rating code from table on page 206 that corresponds to the nominal horsepower rating desired (e.g., 2165QA-1P7AC-**34**).
- Select the appropriate suffix from the Circuit Breaker Type table on page 212 to identify circuit breaker type (e.g., 2165QA-1P7AC-**34CA**).
- The catalog numbers listed include an external reset button for the overload relay. To order catalog numbers **without** the external reset button, replace the letter “A” with the letter “K” (e.g., 2165QA-1P7**K**\_ \_) or replace the letter “D” with the letter “J” (e.g., 2165QA-1P7**J**\_ \_).

## Catalog Number Explanation - Bulletin 2164R and 2165R PowerFlex 700 Drive with Manual Isolated Drive Bypass

- Two interlocked components, one with bypass circuitry and one with drive - drive can be taken offline and replaced as needed with minimal disruption to the application process
- NEMA Enclosure Type 1, Type 1 with gasket or Type 12 Enclosure Type
- NEMA Wiring Class I, Type A
- Isolated logic and power produces a three-phase, pulse-width-modulated (PWM) adjustable frequency output to vary motor speed

243

<b>2164R</b>	<b>A</b>	-	<b>034</b>	<b>A</b>	<b>B</b>	-	<b>44</b>	-	<b>14HA0</b>
<b>2165R</b>	<b>A</b>	-	<b>034</b>	<b>A</b>	<b>B</b>	-	<b>44CA</b>	-	<b>14HA0</b>
<i>Bulletin Number</i>	<i>Wiring Type</i>		<i>PowerFlex 700 Nominal Output Current Rating</i>	<i>NEMA Enclosure Type</i>	<i>Line Voltage</i>		<i>Nominal Horsepower/kW and Circuit Breaker Type</i>		<i>Human Interface Module and Options</i>

243A

Code	Type
2164R	Manual Drive Bypass with PowerFlex 700 VFD Drive and Fusible Disconnect
2165R	Manual Drive Bypass with PowerFlex 700 VFD and Circuit Breaker

243B

Code	Wiring Type
A	Type A

243C

Nominal Constant Current Ratings (Amperes) [1]			
480V Line Voltage		600V Line Voltage	
Code	Ratings	Code	Ratings
1P1	1.1	1P7	1.7
2P1	2.1	2P7	2.7
3P4	3.4	3P9	3.9
5P0	5.0	6P1	6.1
8P0	8	9P0	9
011	11	011	11
014	14	017	17
022	22	022	22
027	27	027	27
034	34	032	32
040	40	041	41
052	52	052	52
065	65	062	62
077	77	077	77
096	96	125	125
125	125	144	144
156	156		
180	180		

[1] Bulletins 2164R and 2165R use **Normal Duty** PowerFlex 700 Drives.

243E

Code	Line Voltage
B	480V
C	600V

243D

Code	NEMA Enclosure Type
A	NEMA Type 1 or Type 1 with gasket w/ external reset button
K	NEMA Type 1 or Type 1 with gasket w/o external reset button
D	NEMA Type 12 w/ external reset button
J	NEMA Type 12 w/o external reset button

243F

Code	Nominal Horsepower/kW Code and Circuit Breaker Type
2164R-"44"	"44" Nominal Horsepower/kW code. See table on page 206.
2165R-"44CA"	"44" Nominal Horsepower/kW code. See table on page 206 "CA" Circuit Breaker Type. See table on page 212.

243G

Code	Human Interface Module and Options
	See options section beginning on page 187

## Variable Frequency AC Motor Drive Units

### Units—2164R

Combination PowerFlex 700 Variable Frequency AC Drive (VFD) with Fusible Disconnect and Manual, Isolated Bypass, 480VAC

- See page 146 for product description.
- All PowerFlex ratings are **Normal Duty**.
- Configuration consists of two units. The bypass unit contains a fusible disconnect, bypass contactor, 6-pole manual bypass switch, control circuit transformer and pull-apart terminal blocks. Drive unit contains PowerFlex 700 variable frequency drive.
- A Human Interface Module (HIM) and a Control Interface Type are required. Select on page 189 and 190.
- See page 238 for Combination Unit Short Circuit Withstand Ratings table.
- Wiring is Type A only. Drive can only accept 16 AWG control wire.
- “Drive On” and “Bypass On” pilot lights (options 4\_ \_) and HAND-OFF-AUTO/HAND START-HAND STOP (option 1F) must be specified. See page 187.
- Unit doors are interlocked.
- DeviceNet Starter Auxiliary (DSA) options (11DSA2 and 11DSA3) are available for the bypass unit of the manual drive bypass configuration.

244

Frame	Maximum Continuous Output Amperes [1]	Nominal HP	NEMA Type 1 and Type 1 w/ gasket		NEMA 12		Delivery Program
		The horsepower ratings shown below are for reference only. PowerFlex 700 drive units should be sized according to the application and output ampere rating.	Space Factor	Catalog Number [2]	Space Factor	Catalog Number [2]	
0	1.1	0.5	3.0	2164RA-1P1A_ _	3.0	2164RA-1P1D_ _	SC-II
	2.1	0.75 - 1		2164RA-2P1A_ _		2164RA-2P1D_ _	
	3.4	1.5 - 2		2164RA-3P4A_ _		2164RA-3P4D_ _	
	5	3		2164RA-5P0A_ _		2164RA-5P0D_ _	
	8	5	2164RA-8P0A_ _	2164RA-8P0D_ _			
	11	7.5	2164RA-011A_ _	2164RA-011D_ _			
1	14	10	3.5	2164RA-014A_ _	3.5	2164RA-014D_ _	
	22	15		2164RA-022A_ _		2164RA-022D_ _	
2	27	20		4.0	2164RA-027A_ _	4.0	
	34	25	2164RA-034A_ _		2164RA-034D_ _		
3	40	30	4.5		2164RA-040A_ _	4.5	
	52	40	5.0	2164RA-052A_ _	5.5	2164RA-052D_ _	
	65	50	5.5	2164RA-065A_ _	6.0	2164RA-065D_ _	
4	77	60	6.0, 35" W [3]	2164RA-077A_ _	6.0, 35" W [3]	2164RA-077D_ _	
5	96	75	6.0	2164RA-096A_ _	6.0	2164RA-096D_ _	
	125	100	35" W, 20" D [4]	2164RA-125A_ _	35" W, 20" D [4]	2164RA-125D_ _	
6	156	125	6.0 45" W, 20" D [4]	2164RA-156A_ _	6.0 45" W, 20" D [4]	2164RA-156D_ _	
	180	150		2164RA-180A_ _	6.0 50" W, 20" D [4]	2164RA-180D_ _	

[1] Ampere ratings are at a 4kHz carrier frequency. If carrier frequencies above 4kHz are selected, the drive output ampere ratings **must** be derated. For derating information, contact your local Rockwell Automation Sales Office and/or refer to *PowerFlex 70/700 Reference Manual*, PFLEX-RM001x-EN-E.

[2] The catalog numbers listed are not complete:

- Select voltage code from table on page 206 (2164RA-034AB).
- Select number from table on page 206 that corresponds to the horsepower rating desired (e.g., 2164RA-034AB-44).
- The catalog numbers listed include an external reset button for the overload relay. To order catalog numbers **without** the external reset button, replace the letter “A” with the letter “K” (e.g., 2164RA-034K\_ \_) or replace the letter “D” with the letter “J” (e.g., 2164RA-034J\_ \_).

[3] Frame mounted unit. Section does not have vertical wireway.

[4] Frame mounted unit. Section does not have vertical wireway. Horizontal bus is 5" deeper than standard.

Combination PowerFlex 700 Variable Frequency AC Drive (VFD) with Fusible Disconnect and Manual, Isolated Bypass, 600VAC

- See page 146 for product description.
- All PowerFlex ratings are **Normal Duty**.
- Configuration consists of two units. The bypass unit contains a fusible disconnect, bypass contactor, 6-pole manual bypass switch, control circuit transformer and pull-apart terminal blocks. Drive unit contains PowerFlex 700 variable frequency drive.
- A Human Interface Module (HIM) and a Control Interface Type are required. Select on page 189 and 190.
- See page 238 for Combination Unit Short Circuit Withstand Ratings table.
- Wiring is Type A only. Drive can only accept 16 AWG control wire.
- “Drive On” and “Bypass On” pilot lights (options 4\_ \_) and HAND-OFF-AUTO/HAND START-HAND STOP (option 1F) must be specified. See page 187.
- Unit doors are interlocked.
- DeviceNet Starter Auxiliary (DSA) options (11DSA2 and 11DSA3) are available for the bypass unit of the manual drive bypass configuration.

245

Frame	Maximum Continuous Output Amperes	Nominal HP	NEMA Type 1 and Type 1 w/ gasket		NEMA 12		Delivery Program
		The horsepower ratings shown below are for reference only. PowerFlex 700 drive units should be sized according to the application and output ampere rating.	Space Factor	Catalog Number [1]	Space Factor	Catalog Number [2]	
0	1.7 [2]	1	3.0	2164RA-1P7A_ _	3.0	2164RA-1P7D_ _	PE-II in U.S.,  SC-II in Canada
	2.7 [2]	1.5 - 2		2164RA-2P7A_ _		2164RA-2P7D_ _	
	3.9 [2]	3		2164RA-3P9A_ _		2164RA-3P9D_ _	
	6.1 [2]	5	3.5	2164RA-6P1A_ _	2164RA-6P1D_ _		
	9 [2]	7.5		2164RA-9P0A_ _	2164RA-9P0D_ _		
1	11 [2]	10	3.5	2164RA-011A_ _	4.0	2164RA-011D_ _	
	17 [2]	15		2164RA-017A_ _		2164RA-017D_ _	
2	22 [2]	20	4.0	2164RA-022A_ _	4.5	2164RA-022D_ _	
	27 [2]	25		2164RA-027A_ _		2164RA-027D_ _	
3	32 [2]	30	4.5	2164RA-032A_ _	5.5	2164RA-032D_ _	
	41 [2]	40	5.0	2164RA-041A_ _		2164RA-041D_ _	
	52 [2]	50		2164RA-052A_ _		2164RA-052D_ _	
4	62 [3]	60	6.0, 35"W [4]	2164RA-062A_ _	6.0, 35"W [4]	2164RA-062D_ _	
5	77 [3]	75	6.0, 35"W, 20"D [5]	2164RA-077A_ _	6.0, 35"W, 20"D [5]	2164RA-077D_ _	
6	125 [3]	100 - 125	6.0, 45"W, 20"D [5]	2164RA-125A_ _	6.0, 45"W, 20"D [5]	2164RA-125D_ _	
	144 [3]	150		2164RA-144A_ _	6.0, 50"W, 20"D [5]	2164RA-144D_ _	

14

[1] The catalog numbers listed are not complete:

- Select voltage code from table on page 206 (2164RA-034AB).
- Select number from table on page 206 that corresponds to the horsepower rating desired (e.g., 2164RA-034AB-44).
- The catalog numbers listed include an external reset button for the overload relay. To order catalog numbers **without** the external reset button, replace the letter “A” with the letter “K” (e.g., 2164RA-034**K**\_ \_) or replace the letter “D” with the letter “J” (e.g., 2164RA-034**J**\_ \_).

[2] Ampere ratings are at a 4kHz carrier frequency. If carrier frequencies above 4kHz are selected, the drive output ampere ratings **must** be derated. For derating information, contact your local Rockwell Automation Sales Office and/or refer to *PowerFlex 70/700 Reference Manual*, PFLEX-RM001x-EN-E.

[3] Ampere ratings are at 2kHz carrier frequency. If carrier frequencies above 2kHz are selected, the drive output current ratings **may** require derating. Contact your local Rockwell Automation Sales Office and to *PowerFlex 70/700 Reference Manual*, PFLEX-RM001x-EN-E.

[4] Frame mounted unit. Section does not have vertical wireway.

[5] Frame mounted unit. Section does not have vertical wireway. Horizontal bus is 5” deeper than standard.

Combination PowerFlex 700 Variable Frequency AC Drive (VFD) with Circuit Breaker Disconnect and Manual, Isolated Bypass, 480VAC

- See page 146 for product description.
- All PowerFlex ratings are **Normal Duty**.
- Configuration consists of two units. The bypass unit contains a circuit breaker, bypass contactor, 6-pole manual bypass switch, control circuit transformer and pull-apart terminal blocks. Drive unit contains PowerFlex 700 variable frequency drive.
- A Human Interface Module and a Control Interface Type are required. Select on page 189 and 190.
- See page 238 for Combination Unit Short Circuit Withstand Ratings table.
- Wiring is Type A only. Drive can only accept 16 AWG control wire.
- Unit doors are interlocked.
- DeviceNet Starter Auxiliary (DSA) options (11DSA2 and 11DSA3) are available for the bypass unit of the manual drive bypass configuration.
- “Drive On” and “Bypass On” pilot lights (option 4\_ \_) and HAND-OFF-AUTO/HAND START-HAND STOP (option 1F) must be specified. See page 187.

246

Frame	Maximum Continuous Output Amperes [1]	Nominal HP	NEMA Type 1 and Type 1 w/ gasket		NEMA 12		Delivery Program	
		The horsepower ratings shown below are for reference only. PowerFlex 700 drive units should be sized according to the application and output ampere rating.	Space Factor	Catalog Number [2]	Space Factor	Catalog Number [2]		
0	1.1	0.5	3.0	2165RA-1P1A_ _	3.0	2165RA-1P1D_ _	SC-II	
	2.1	0.75 - 1		2165RA-2P1A_ _		2165RA-2P1D_ _		
	3.4	1.5 - 2		2165RA-3P4A_ _		2165RA-3P4D_ _		
	5	3		2165RA-5P0A_ _		2165RA-5P0D_ _		
	8	5	2165RA-8P0A_ _	2165RA-8P0D_ _				
	11	7.5	2165RA-011A_ _	2165RA-011D_ _				
1	14	10	3.5	2165RA-014A_ _	3.5	2165RA-014D_ _		
	22	15		2165RA-022A_ _		2165RA-022D_ _		
2	27	20	4.0	2165RA-027A_ _	4.0	2165RA-027D_ _		
	34	25		2165RA-034A_ _		2165RA-034D_ _		
3	40	30		4.5	2165RA-040A_ _	4.5		2165RA-040D_ _
	52	40		5.0	2165RA-052A_ _	5.5		2165RA-052D_ _
	65	50	5.5	2165RA-065A_ _	6.0	2165RA-065D_ _		
4	77	60	6.0, 35" W <sup>[3]</sup>	2165RA-077A_ _	6.0, 35" W <sup>[3]</sup>	2165RA-077D_ _		
5	96	75	6.0	2165RA-096A_ _	6.0	2165RA-096D_ _		
	125	100	35" W, 20" D <sup>[4]</sup>	2165RA-125A_ _	35" W, 20" D <sup>[4]</sup>	2165RA-125D_ _		
6	156	125	6.0 45" W, 20" D <sup>[4]</sup>	2165RA-156A_ _	6.0 45" W, 20" D <sup>[4]</sup>	2165RA-156D_ _		
	180	150		2165RA-180A_ _	6.0 50" W, 20" D <sup>[4]</sup>	2165RA-180D_ _		

[1] Ampere ratings are at a 4kHz carrier frequency. If carrier frequencies above 4kHz are selected, the drive output ampere ratings **must** be derated. For derating information, contact your local Rockwell Automation Sales Office and/or refer to *PowerFlex 70/700 Reference Manual*, PFLEX-RM001x-EN-E.

[2] The catalog numbers listed are not complete:

- Select voltage code from table on page 206 (e.g., 2165RA-034AB).
- Select number from table on page 206 that corresponds to the kilowatt rating desired (e.g., 2165RA-034AB-44).
- Select the appropriate suffix from table on page 212 to identify the circuit breaker type (e.g., 2165RA-037AN-44KCA).
- The catalog numbers listed include an external reset button for the overload relay. To order catalog numbers **without** the external reset button, replace the letter “A” with the letter “K” (e.g., 2165RA-034K\_ \_) or replace the letter “D” with the letter “J” (e.g., 2165RA-034J\_ \_).

[3] Frame mounted unit. Section does not have vertical wireway.

[4] Frame mounted unit. Section does not have vertical wireway. Horizontal bus is 5" deeper than standard.

Combination PowerFlex 700 Variable Frequency AC Drive (VFD) with Circuit Breaker and Manual, Isolated Bypass, 600VAC

- See page 146 for product description.
- All PowerFlex ratings are **Normal Duty**.
- Configuration consists of two units. The bypass unit contains a fusible disconnect, bypass contactor, 6-pole manual bypass switch, control circuit transformer and pull-apart terminal blocks. Drive unit contains PowerFlex 700 variable frequency drive.
- A Human Interface Module (HIM) and a Control Interface Type are required. Select on page 189 and 190.
- See page 238 for Combination Unit Short Circuit Withstand Ratings table.
- Wiring is Type A only. Drive can only accept 16 AWG control wire.
- “Drive On” and “Bypass On” pilot lights (option 4\_ \_) and HAND-OFF-AUTO/HAND START-HAND STOP (option 1F) must be specified. See page 187.
- Unit doors are interlocked.
- DeviceNet Starter Auxiliary (DSA) options (11DSA2 and 11DSA3) are available for the bypass unit of the manual drive bypass configuration.

247

Frame	Maximum Continuous Output Amperes	Nominal HP	NEMA Type 1 and Type 1 w/ gasket		NEMA 12		Delivery Program
		The horsepower ratings shown below are for reference only. PowerFlex 700 drive units should be sized according to the application and output ampere rating.	Space Factor	Catalog Number [1]	Space Factor	Catalog Number [2]	
0	1.7 [2]	1	3.0	2165RA-1P7A_ _	3.0	2165RA-1P7D_ _	PE-II in U.S.,  SC-II in Canada
	2.7 [2]	1.5 - 2		2165RA-2P7A_ _		2165RA-2P7D_ _	
	3.9 [2]	3		2165RA-3P9A_ _		2165RA-3P9D_ _	
	6.1 [2]	5	3.5	2165RA-6P1A_ _	2165RA-6P1D_ _		
	9 [2]	7.5		2165RA-9P0A_ _	2165RA-9P0D_ _		
1	11 [2]	10	3.5	2165RA-011A_ _	4.0	2165RA-011D_ _	
	17 [2]	15		2165RA-017A_ _		2165RA-017D_ _	
2	22 [2]	20	4.0	2165RA-022A_ _	4.5	2165RA-022D_ _	
	27 [2]	25		2165RA-027A_ _		2165RA-027D_ _	
3	32 [2]	30	4.5	2165RA-032A_ _	5.5	2165RA-032D_ _	
	41 [2]	40	5.0	2165RA-041A_ _		2165RA-041D_ _	
	52 [2]	50		2165RA-052A_ _		2165RA-052D_ _	
4	62 [3]	60	6.0, 35"W [4]	2165RA-062A_ _	6.0, 35"W [4]	2165RA-062D_ _	
5	77 [3]	75	6.0, 35"W, 20"D [5]	2165RA-077A_ _	6.0, 35"W, 20"D [5]	2165RA-077D_ _	
6	125 [3]	100 - 125	6.0, 45"W, 20"D [5]	2165RA-125A_ _	6.0, 45"W, 20"D [5]	2165RA-125D_ _	
	144 [3]	150		2165RA-144A_ _	6.0, 50"W, 20"D [5]	2165RA-144D_ _	

[1] The catalog numbers listed are not complete:

- Select voltage code from table on page 206 (2164RA-034AB).
- Select number from table on page 206 that corresponds to the horsepower rating desired (e.g., 2165RA-034AB-44).
- The catalog numbers listed include an external reset button for the overload relay. To order catalog numbers **without** the external reset button, replace the letter “A” with the letter “K” (e.g., 2165RA-034**K**\_ \_) or replace the letter “D” with the letter “J” (e.g., 2165RA-034**J**\_ \_).
- Select the appropriate suffix from the table on page 212 to identify the circuit breaker type (e.g., 2165RA-022AC-33**CA**)

[2] Ampere ratings are at a 4kHz carrier frequency. If carrier frequencies above 4kHz are selected, the drive output ampere ratings **must** be derated. For derating information, contact your local Rockwell Automation Sales Office and/or refer to *PowerFlex 70/700 Reference Manual*, PFLEX-RM001x-EN-E.

[3] Ampere ratings are at 2kHz carrier frequency. If carrier frequencies above 2kHz are selected, the drive output current ratings **may** require derating. Contact your local Rockwell Automation Sales Office and to *PowerFlex 70/700 Reference Manual*, PFLEX-RM001x-EN-E.

[4] Frame mounted unit. Section does not have vertical wireway.

[5] Frame mounted unit. Section does not have vertical wireway. Horizontal bus is 5" deeper than standard.



# Factory-Installed Options, Modifications, Accessories for Combination Variable Frequency AC Motor Drive Units

Multiple option numbers are separated by a dash and added to the base catalog number in ascending order.

To select pilot light lens color, add letter(s) to the option number: A = amber, B = blue, C = clear, G = green, R = red, W = white (e.g., 4RG is a red ON and green OFF pilot light). Clear and white are not available for Bulletin 800T LED type pilot lights. Clear is not available on Bulletin 800F LED pilot lights. White is not available on Bulletin 800F incandescent pilot lights.

248

Option	Description	PowerFlex 40, 70 and 700 Drives		PowerFlex 70 and 700 Manual Drive Bypass		Option Number	Delivery Program	
		2162Q 2162R 2163Q 2163R	2162T 2163T	2164Q 2164R.	2165Q 2165R			
Push Buttons <sup>[1],[2],[3]</sup>	DRIVE START-DRIVE STOP	✓ <sup>[4]</sup>	✓ <sup>[5]</sup>			-1	SC	
	JOG	✓ <sup>[4]</sup>				-1E		
Push Buttons and Selector Switch <sup>[1]</sup>	HAND-OFF-AUTO, HAND START-HAND STOP			✓ <sup>[6]</sup>	✓ <sup>[6]</sup>	-1F		
Selector Switch <sup>[1],[2],[3]</sup>	AUTO-MANUAL (speed select)	✓ <sup>[4]</sup>	✓ <sup>[5]</sup>			-3		
	FORWARD-REVERSE	✓ <sup>[4]</sup>				-3E		
	HAND-OFF-AUTO	✓ <sup>[4]</sup>	✓ <sup>[5]</sup>			-3F		
Pilot Lights (Transformer Type for 800T, full voltage 800F) <sup>[1],[3]</sup>	Standard type	RUN	✓	✓		-4__		
		RUN-AT SPEED	✓			-4__		
		BYPASS ON-DRIVE ON			✓ <sup>[6]</sup>	✓ <sup>[6]</sup>		-4__
	LED type	RUN	✓	✓				-4L__
		RUN-AT SPEED	✓					-4L__
		BYPASS ON-DRIVE ON			✓ <sup>[6]</sup>	✓ <sup>[6]</sup>		-4L__
	Push-to-Test standard type	RUN	✓	✓				-5__
		RUN-AT SPEED	✓					-5__
		BYPASS ON-DRIVE ON			✓ <sup>[6]</sup>	✓ <sup>[6]</sup>		-5__
	Push-to-Test LED type	RUN	✓	✓			-5L__	
		RUN-AT SPEED	✓				-5L__	
		BYPASS ON-DRIVE ON			✓ <sup>[6]</sup>	✓ <sup>[6]</sup>	-5L__	

[1] When three (3) or less pilot devices are selected Bulletin 800T pilot devices are supplied except selector switches are Bulletin 800H devices. When more than three (3) pilot lights are selected, 800F pilot devices are supplied.

[2] Options 1, 1E, and 3E are not available with communication module 14GC, 14GD, 14GE, 14GR.

[3] Extra space may be required for Bulletin 2162Q, 2163Q, 2162T, 2163T, refer to specific drive selection pages for specific space factor adders.

[4] Option -3F is mutually exclusive with option -1, -1E, -3, and -3E.

[5] For Bulletin 2162T and 2163T, option -1, -3, and -3F are mutually exclusive with each other.

[6] Push button and selector switch and pilot lights must be specified for Bulletin 2164Q, 2165Q, 2164R and 2165R units.

## Factory-Installed Options, Modifications, Accessories for Combination Variable Frequency AC Motor Drive

Multiple option numbers are separated by a dash and added to the base catalog number in ascending order.

250

Option	Option Number	Description	PowerFlex 40, 70 and 700 Drives		PowerFlex 70 and 700 Manual Drive Bypass		Delivery Program
			2162Q 2163Q 2162R 2163R	2162T 2163T	2164Q 2164R	2165Q 2165R	
DeviceNet Communication Modules (mutually exclusive)	-11DSA2	For use with contactors and starters to provide DeviceNet inputs and outputs. <b>(4) 120V</b> inputs and (2) 120V outputs. Not to be used with options 7FEC_ or 7FC_. Available for 110V-120V control only.			✓ <sup>[1]</sup>	✓ <sup>[1]</sup>	SC
	-11DSA3	For use with contactors and starters to provide DeviceNet inputs and outputs. <b>(4) 24VDC</b> inputs and (2) 240VAC (max), 30VDC (max) outputs. Not to be used with 7FEC_ or 7FC_. Available for 110V-120VAC or 220V-240VAC control voltage.			✓ <sup>[1]</sup>	✓ <sup>[1]</sup>	
Communication Module <sup>[2]</sup>	-14GC	ControlNet Communication Module, Mounted Internal to Drive. Includes one 1786-TPYS tap, supplied loose for customer mounting	✓	✓ <sup>[3]</sup>	✓	✓	
	-14GD	DeviceNet communication module, mounted internal to drive	✓	✓ <sup>[3]</sup>	✓ <sup>[1]</sup>	✓ <sup>[1]</sup>	
	-14GE	Ethernet communication module. Mounted internal to drive.	✓	✓ <sup>[3]</sup>	✓	✓	
	-14GR	Remote I/O communication module, mounted internal to drive	✓		✓	✓	

[1] When DeviceNet communication is required, select DeviceNet Communication Module (Option 14GD) and DeviceNet Starter Auxiliary (Option 11DSA2 or 11DSA3).

[2] Communication modules (options -14GC, 14GD, 14GE, and 14GR) are mutually exclusive on Bulletins 2162Q, 2162R, 2163Q, 2163R, 2164Q, 2164R, 2165Q, 2165R, 2162T and 2163T.

[3] For Bulletin 2162T and 2163T, when 14GC, 14GD or 14GE is specified with Human Operator Interface Module (Option 14HBA3 or 14HC2S) speed control on the Human Interface Module is not functional.

## Factory-Installed Options, Modifications, Accessories for Combination Variable Frequency AC Motor Drive

Multiple option numbers are separated by a dash and added to the base catalog number in ascending order.

251

Option	Option Number	Description	PowerFlex 40, 70 and 700 Drives		PowerFlex 70 and 700 Manual Drive Bypass		Delivery Program	
			2162Q 2163Q 2162R 2163R	2162T 2163T	2164Q 2164R	2165Q 2165R		
Human Interface Module (HIM) <sup>[1]</sup>  (mutually exclusive)	-14HBA0	No HIM (blank plate)	Mounted in bezel on the door.	✓	✓	✓	✓	SC
	-14HBA3	LCD display, full numeric keypad	HIM is removable. NEMA 1, 1G only. Cable to drive is included.	✓	✓	✓	✓	
	-14HBA5	LCD display, programmer only		✓		✓	✓	
	-14HA0	No HIM (blank plate)	Mounted inside unit on drive.	✓ [2]		✓	✓	
	-14HA3	LCD display, full numeric keypad	Available on NEMA Type 1, 1 with gasket and 12. Includes viewing window on door.	✓ [2]		✓	✓	
	-14HA5	LCD display, programmer only		✓ [2]		✓	✓	
	-14HC2S	LCD display, digital keypad	Door mounted. HIM is not removable. Cable to drive is included. <b>NEMA Type 12 Only.</b>		✓			
	-14HC3S	LCD display, full numeric keypad		✓		✓	✓	
	-14HC5S	LCD display, programmer only		✓		✓	✓	

[1] A Human Interface Module (HIM) must be selected, except on Bulletin 2162T and 2163T. Optional door mounted HIMs are available for 2162T and 2163T units. Bulletin 2162T and 2163T drives include an integral HIM as standard. Bulletin 2162T and 2163T drives include a viewing window over the integral HIM module when optional HIM is not selected.

[2] Not available on Bulletin 2162R and 2163R with size code 300.

## Factory-Installed Options, Modifications, Accessories for Combination Variable Frequency AC Motor Drive

Multiple option numbers are separated by a dash and added to the base catalog number in ascending order.

252

Option	Option Number	Description	PowerFlex 40, 70 and 700 Drives			PowerFlex 70 and 700 Manual Drive Bypass		Delivery Program
			2162Q 2163Q	2162R 2163R	2162T 2163T	2164Q 2165Q	2164R 2165R	
Encoder Feedback	-14ENC1	Encoder Feedback Module, 12V		✓ <sup>[1]</sup>			✓	SC
I/O Control Interface Type <sup>[2]</sup>	-14DA1C	24 VDC Control Voltage Interface with Vector Control		✓ <sup>[1]</sup>			✓ <sup>[1]</sup>	SC
	-14DA1D	120 VAC Control Voltage Interface with Vector Control		✓ <sup>[1]</sup>			✓ <sup>[1]</sup>	
	-14DA1E	24 VDC Control Voltage with Sensorless Vector Control		✓ <sup>[3]</sup>				
	-14DA1F	120 VAC Control Voltage with Sensorless Vector Control		✓ <sup>[3]</sup>				
Enhanced Control Platform Type <sup>[4]</sup>	-14C0	Enhanced control for PowerFlex 70 drive units	✓			✓		SC
	-14G0	Enhanced control for PowerFlex 70 drive units with DriveGuard Safe-off Option	✓			✓		
Analog Output Isolation	-14N2	Provides a DC signal that is proportional to the drive DC output signal. The signal is fully isolated from the drive output, line power and ground.	✓	✓	✓ <sup>[5]</sup>	✓	✓	SC
Ungrounded Power System	-14PSUG	This option disconnects internal drive protective devices which are referenced to ground. This option is required if the drive will be used on an ungrounded power system or a power system which is grounded through any impedance.	✓	✓ <sup>[6]</sup>		✓	✓	

[1] Available only for Bulletin 2162R, 2163R, 2164R and 2165R units, except units with size code 300.

[2] Control type **MUST** be selected for Bulletin 2162R, 2163R, 2164R and 2165R.

[3] Available only for Bulletin 2162R and 2163R with size code 300.

[4] Enhanced control option **MUST** be specified.

[5] Space factor adder may be required for Bulletin 2162T and 2163T. See pages 172-175.

[6] For size code 300, Bulletin 2162R and 2163R, option -14PSUG changes delivery program to Engineered. Contact your local Rockwell Automation Sales Office for availability.

## Factory-Installed Options, Modifications, Accessories for Combination Variable Frequency AC Motor Drive

A **load reactor** (connecting a reactor on the load side of the drive) should be considered as a means to address one or more of the following issues:

- 1.) Multi-motor applications (one drive feeding more than one motor).
- 2.) A low voltage insulation class motor applied on a long cable length.
- 3.) 575V motor applications (other than short cable length applications).

A **load reactor** is NOT required for applications where:

- 1.) Line voltage is 230V or less.
- 2.) A Bulletin 1204 terminator unit is utilized.
- 3.) An Allen-Bradley controlled matched solution is being applied (e.g., a 1850V CIV motor is used for a cable length of 600 ft. [185 m] or less in a 575V application).

A **line reactor** (connecting a reactor on the line side of the drive) should be considered as a means to address one or more of the following issues:

- 1.) Applications with severe power line transient disturbances degrading the power quality of the incoming power line (e.g., arcing during power line switching, arc welder applications, or switching of a system power factor correction capacitor bank at the main service [especially if the PFCC bank is switched by a vacuum contactor]).
- 2.) Applications utilizing improvement of power line harmonic content.  
 –However, due to the built-in DC link reactor internal to the Allen-Bradley IGBT-based PWM drives, a line reactor will usually have little effect on the improvement of power line harmonic distortion.
- 3.) Applications exposed to excessive high voltage transients due to lightning.  
 –However, a surge protective device unit for the total MCC is recommended for such applications (e.g., catalog #2100-SPKB-1, catalog #2100-SPKC-1, etc.).

Applications with **both line and load reactors** are not recommended without first contacting your local Rockwell Automation Sales Office. While this application is not detrimental to the drive itself, it may produce erroneous drive operation caused by effects of common mode current. These effects can be influenced by drive HP, carrier frequency, motor load and output cable length. Contact your local Rockwell Automation Sales Office when both line and load reactors are deemed necessary for the application.

Additional recommendations are available in the specific IGBT-based PWM inverter user manual. Consult these manuals for restrictions regarding drive carrier frequency, motor cable length and motor insulation class (inverter class motors). Information on the use of reactors and the use of Bulletin 1204 terminators can also be found in the user manuals.

Multiple option numbers are separated by a dash and added to the base catalog number in ascending order.

253

Option	Option Number	Description	PowerFlex 40, 70 and 700 Drives		PowerFlex 70 and 700 Manual Drive Bypass		Delivery Program		
			2162Q 2162R 2162T	2163Q 2163R 2163T	2164Q 2164R	2165Q 2165R			
Line or Load Reactors [1]	-14R_ [2] (See space factor adders on page 192)	3% impedance line or load reactor.	480V	0.5-1 HP	✓	✓	✓	✓	SC
				1.5-2 HP	✓	✓	✓	✓	
				3-5 HP	✓	✓	✓	✓	
				7.5 HP	✓	✓	✓	✓	
				10 HP	✓	✓	✓	✓	
				15 HP	✓	✓	✓	✓	
				20-25 HP	✓	✓	✓	✓	
				30 HP	✓	✓	✓	✓	
				40 HP	✓	✓	✓	✓	
				50-60 HP	✓	✓	✓	✓	
				75 HP	✓	✓	✓	✓	
				100 HP	✓	✓	✓	✓	
				125 HP	✓	✓	✓	✓	
				150 HP <sup>[3]</sup>	✓	✓	✓	✓	
				600V	1 HP	✓	✓	✓	
			2 HP		✓	✓	✓	✓	
			3-7.5 HP		✓	✓	✓	✓	
			10 HP		✓	✓	✓	✓	
			15 HP		✓	✓	✓	✓	
			20-25 HP		✓	✓	✓	✓	
			30 HP		✓	✓	✓	✓	
40 HP	✓	✓	✓		✓				
480V	-14RXL __ [2]	3% impedance load reactor for size code 300, Bulletin 2162R and 2163R drive units	150HP <sup>[3]</sup>	✓	✓			PE-II	
			200 HP	✓	✓				

15

[1] **Line and load reactors are mutually exclusive**, as space factor adders may be required see page 192.  
 [2] The option numbers listed are not complete:  
 Select **LX** for line reactor or **XL** for load reactors (e.g., 14RLX).  
 • For Bulletin 2162R and 2163R, size code 300 drive units (150HP Heavy Duty at 480V and 200HP at 480V), select the drive supplementary unit identification code (01-99) (e.g., 14RLX01). The supplementary unit identification code must begin with "01" and increase sequentially with multiple drive units ("02," "03," "04," etc.). Each drive unit is to have a unique supplementary unit identification code that correlates with the same identification code on the supplementary unit. **See page 148 for catalog number.**  
 [3] For 150 hp, 480 V, Heavy Duty, Bulletin 2162R and 2163R units, refer to footnote [2], [4] and [5].  
 [4] Load reactors for Bulletin 2162R and 2163R, size code 300 drive units (150HP Heavy Duty at 480V and 200HP at 480V) are separate units from the drive units. The load reactors require an additional section mounted to the right of the section with the drive. The reactor will be mounted in a supplementary drive unit in the bottom of the additional section. The two (2) sections will be one (1) shipping block. Not available in back-to-back construction.  
 [5] Bulletin 2162R and 2163R, size code 300 rated units have approximately 3% of inherent line reactance.

**Space Factor Adders for Bulletins 2162Q and 2163Q**  
480V 255

NEMA Type	Rating Code	Space Factor Adder
1, 1G	1P1	0.5
	2P1	
	3P4	
	5P0	
	8P0	
	011	
	014	
	052	
12	065	[1]
	034	0.5
	065	[1]

[1] See unit pages for space factor adders.

**600V** 256

NEMA Type	Rating Code	Space Factor Adder
1, 1G	0P9	0.5
	1P7	
	2P7	
	3P9	
	6P1	
	9P0	
	011	
	041	
	052	
	027	
12	027	0.5
	032	

**Space Factor Adders for Bulletins 2164Q and 2165Q**  
480V 257

NEMA Type	Rating Code	Space Factor Adder
12	5P0	0.5
	8P0	
	011	
	014	

**600V** 258

NEMA Type	Rating Code	Space Factor Adder
12	3P9	0.5
	6P1	
	9P0	
	011	

**Space Factor Adders for Bulletins 2162R and 2163R**  
480V 259

NEMA Type	Rating Code	Space Factor Adder
1, 1G	027 <sup>[1]</sup>	0.5
	034	
	040	
	052	
	065 <sup>[2]</sup>	
12	065 <sup>[2]</sup>	0.5, 1.0
	1P1 <sup>[1]</sup>	0.5
	2P1 <sup>[1]</sup>	
	3P4 <sup>[1]</sup>	
	5P0 <sup>[1]</sup>	
	034	
	040	

**600V** 260

NEMA Type	Rating Code	Space Factor Adder
1, 1G	022 <sup>[1]</sup>	0.5
	027	
	032	
	041	
	052 <sup>[3]</sup>	
	1P7 - 3P9 <sup>[1]</sup>	
12	027	0.5
	032	

[1] Bulletin 2163R only.

[2] Bulletin 2162R requires 1.0 space factor adder and Bulletin 2163R requires 0.5 space factor adder.

[3] Bulletin 2162R only.

**Space Factor Adders for Line or Load Reactors**

**Space Factor Adders for Bulletins 2164R and 2165R**  
480V 261

NEMA Type	Rating Code	Space Factor Adder
1, 1G	034	0.5
	065	
12	014	
	034	
	040	

**600V** 262

NEMA Type	Rating Code	Space Factor Adder
1, 1G	027	0.5
12	027	
	032	

15

## Factory-Installed Options, Modifications, Accessories for Combination Variable Frequency AC Motor Drive

Multiple option numbers are separated by a dash and added to the base catalog number in ascending order.

263

			PowerFlex 40, 70 and 700 Drives		PowerFlex 70 and 700 Manual Drive Bypass		Delivery Program	
Option	Option Number	Description	2162Q 2162R 2162T	2163Q 2163R 2163T	2164Q 2164R	2165Q 2165R		
Grounded Unit Door <sup>[1]</sup>	-79GD	Hinge mounted ground strap mounted on hinge of unit door. Unit door grounding strap for IEC requirements.	✓	✓	✓	✓	SC	
Unit Load Connector	-79L	Specify on plug-in units for sections with unplated vertical unit load ground bus	✓	✓	✓	✓		
	-79LT	Specify on plug-in units for sections with tin plated vertical unit load ground bus	✓	✓	✓	✓		
Unit Ground Stab	—	Specify on plug-in units for sections with vertical plug-in ground bus. Unplated copper unit ground stab can also be used with steel vertical ground bus.	✓	✓	✓	✓		
	-79U	Unplated copper	✓	✓	✓	✓		
	-79UT	Tin plated cooper	✓	✓	✓	✓		
Auxiliary Contacts	-98 <sup>[2]</sup>	Normally Open—One (1) N.O. mounted on operating mechanism (operates with movement of external handle only)	✓	✓	✓	✓		
	-98X <sup>[3]</sup>	Normally Open—One (1) N.O. mounted internally. Circuit breaker units only.	✓	✓	✓	✓		
	-99 <sup>[2]</sup>	Normally Closed—One (1) N.C. mounted on operating mechanism (operates with movement of external handle only)	✓	✓	✓	✓		
	-99X <sup>[3]</sup>	Normally Closed—One (1) N.C. mounted internally. Circuit breaker units only.	✓	✓	✓	✓		
T-Handle	-111	T-Handle latch on unit door. Not available on 2160R units.	✓	✓	✓	✓		
Control Circuit Wiring	—	Type MTW (TEW) 90°C #16 AWG copper wire, VW1 rated	✓	✓	✓	✓		
Control Wire Markers	-751D	Brady Datab wire markers at each end of the control wires. Not available in Canada.	✓	✓	✓	✓	SC (+2 days)	
	-751HS	Heat shrink type wire markers	✓	✓	✓	✓		
	-751S	Sleeve type wire marker	✓	✓	✓	✓		
French Legend Plates	-860F	Legend plates printed in French are available on all pilot devices. Specify 860F when pilot device options are selected.	✓	✓	✓	✓	SC	
Spanish Legend Plates	-860S	Legend plates printed in Spanish are available on all pilot devices. Specify 860S when pilot device options are selected.	✓	✓	✓	✓		
Unit Door Nameplates <sup>[1]</sup>	—	Door Nameplate Screws	Plated steel nameplate screws. Provided when cardholder or nameplates are not selected.	✓	✓	✓	✓	SC-II
		Card Holder for Unit Doors	1.125" x 3.625" plastic card holders with blank cards	✓	✓	✓	✓	
		1.125" x 3.625" engraved 3-line nameplate or 4-line nameplate	Acrylic plate (available in U.S. only). Nameplate is white with black letters or black with white letters.	✓	✓	✓	✓	
			Phenolic plate. Nameplate is white with black letters or black with white letters.	✓	✓	✓	✓	
Stainless Steel Nameplate Screws <sup>[1]</sup>	—	Stainless steel nameplate screws for unit nameplates (2 per unit)	✓	✓	✓	✓		
Export Packing Below Deck	—	Container is skid mounted and packaged in clear plastic. Packing is not watertight or waterproof. Extended storage may require space heater and other considerations. For sections, see page 28.	✓	✓	✓	✓	SC (+2 days)	

[1] Also available on Bulletin 2160R units.

[2] The maximum number of auxiliary contacts that can be supplied internally is two (2), in any combination. Contacts actuate with movement of unit handle to ON or OFF position only. Contacts are not designed to actuate as a result of a circuit breaker trip. For such applications, auxiliary contacts mounted internally (98X or 99X) must be selected. Auxiliary contacts are supplied unwired.

[3] The maximum number of auxiliaries that can be supplied is two (2). These are form C contacts. Each form C contact includes one N.O. and one N.C. contact. Internal auxiliary contacts (98X or 99X) are wired to a 3-point floating terminal block.



# Programmable Controller Units and Marshalling Panels

## Bulletin 2180E, 2182E, 2183E

### with Bulletin 1771 Programmable I/O Chassis ..... 198

Bulletin 2180E, 2182E and 2183E units contain one or more Bulletin 1771 input/output chassis. Space factors depend on the specific features, options, modifications and accessories selected. Power supply and terminal blocks are optional.

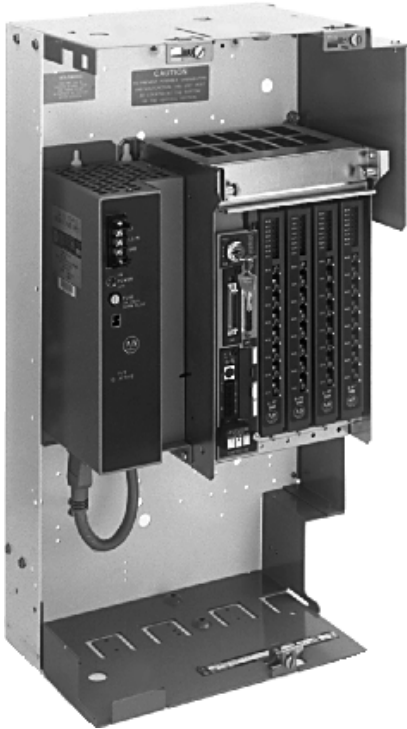

#### Unit features:

- Without disconnecting means or plug-in stabs, one 4-slot or 8-slot chassis in 2.0 space factor units.
- With disconnecting means (15A trip circuit breaker or 30A disconnect switch), control circuit transformer and plug-in stabs, one 4-slot or 8-slot chassis in 3.0 space factor units.
- Viewing window in the door to permit visual verification of the I/O status indicators.

**NOTE:** Plug-in units must be located in the bottom of the vertical section.

#### 25" and 35" wide full section features:

- One 8-slot chassis in 25" wide section, with or without horizontal bus.
- Two 8-slot chassis in 25" wide section, with or without horizontal bus.
- One or two 16-slot chassis with 35" wide section.
- Can be specified without or with disconnecting means (30A trip circuit breaker or 30A disconnect switch) and control circuit transformer (non-isolated).
- Viewing window in the door to permit visual verification of the I/O status indicators.

#### 40" wide full section features:

- 15" deep without horizontal bus, 20" deep with or without horizontal bus. Bus splice access is from rear (removal of backplates is necessary).
- Horizontal power bus is 5" deeper than standard.
- Two 20" wide doors with vault-style latching mechanism.
- 0.25" x 1" ground bus is supplied as standard.
- For Bulletin 2180E—one, two, or three 16-slot chassis without disconnecting means.
- For Bulletins 2182E and 2183E—one or two 16-slot chassis with disconnecting means (30A trip or 30A disconnect switch) and primary fused transformer (non-isolated), six (6) 1-pole 10A circuit breakers, duplex receptacle and a power distribution terminal block.
- Isolated ground bus for each chassis included.
- Viewing windows in the doors permit visual verification of the I/O status indicators.
- Wire ducts included.
- Optional fluorescent light and door switch.

## Bulletin 2180J, 2182J, 2183J

### with Bulletin 1746 SLC 500 Chassis ..... 199

#### Unit features:

- One 7-slot I/O chassis.
- Without disconnecting means or plug-in stabs in 1.0 space factor units. Includes unwired master control relay (Bulletin 700CF, 4-pole).
- With disconnecting means (15A trip circuit breaker or 30A disconnect switch) and plug-in stabs in 1.5 space factor units. Includes 750VA transformer with primary fusing and unwired master control relay (Bulletin 700CF, 4-pole).
- Viewing window in the door to permit visual verification of the I/O status indicators.
- Optional power supply.

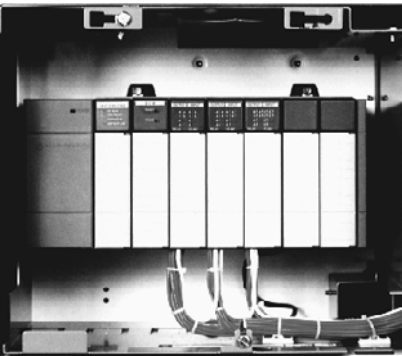

**Bulletin 2180L, 2182L, 2183L  
with Bulletin 1756 ControlLogix Chassis ..... 200**

The Bulletin 2180L, 2182L and 2183L units include a choice of (1) 4-slot or (1) 7-slot Bulletin 1756 ControlLogix chassis.

**Unit features:**

Without disconnecting means or plug-in stabs

- 4-slot chassis, 1.0 space factor.
- 7-slot chassis, 2.0 space factor (frame mounted unit, section does not have vertical wireway next to this unit). Bottom mounted only.

With disconnecting means:

- Fusible disconnect (30A switch), plug-in stabs, control circuit transformer, 4-slot chassis, 1.5 space factor.
- Fusible disconnect (30A switch) without plug-in stabs, control circuit transformer, 7-slot chassis, 2.0 space factor (frame mounted unit, section does not have vertical wireway next to this unit). Bottom mounted only.
- Circuit breaker (15A trip), plug-in stabs, control circuit transformer, 4-slot chassis, 1.5 space factor.
- Circuit breaker (15A trip) without plug-in stabs, control circuit transformer, 7-slot chassis, 2.0 space factor (frame mounted unit, section does not have vertical wireway next to this unit). Bottom mounted only.

Unit options include:

- Processor cards (all memory upgrade options).
- Communication cards (Ethernet, ControlNet, DeviceNet, RI/O DH+).
- Power supply (10.0A)

**Bulletin 2181B  
Marshalling Panels ..... 202**

- 20" wide full section with (366) 1492-CA1 or (620) 1492-HM1 terminal blocks.
- 40" wide full section with (915) 1492-CA1 or (1550) 1492-HM1 terminal blocks.
- 15" and 20" deep without horizontal bus. Wire ducts included.

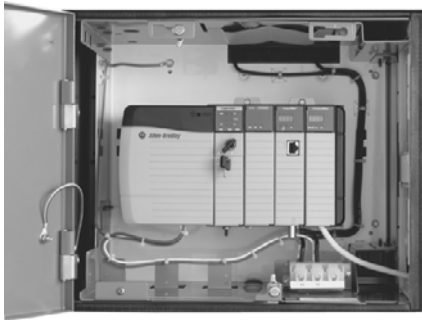

Catalog Number Explanation - Bulletin 2180, 2182 and 2183

Programmable Control I/O Chassis Units

- NEMA Enclosure Type 1, Type 1 with gasket and Type 12
- Type A Wiring

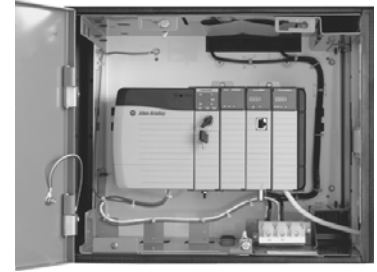

264

<b>2180E</b>	-	<b>A</b>	<b>K</b>	<b>XWD</b>	-	<b>**</b>
<b>2182E</b>	-	<b>A</b>	<b>K</b>	<b>B</b>	-	<b>**</b>
<b>2183E</b>	-	<b>A</b>	<b>K</b>	<b>B</b>	-	<b>**</b>

Bulletin Number	Number of I/O Chassis and Slots	NEMA Enclosure Type	Line Voltage	Trip Current and Circuit Breaker Type	Options
-----------------	---------------------------------	---------------------	--------------	---------------------------------------	---------

Code	Type
2180E	Bulletin 1771 Programmable Controller (PLC) I/O Chassis without Disconnecting Means
2182E	Bulletin 1771 Programmable Controller (PLC) I/O Chassis with Fusible Disconnect
2183E	Bulletin 1771 Programmable Controller (PLC) I/O Chassis with Circuit Breaker
2180J	Bulletin 1746 SLC 500 Programmable Controller (PLC) I/O Chassis without Disconnecting Means
2182J	Bulletin 1746 SLC 500 Programmable Controller (PLC) I/O Chassis with Fusible Disconnect
2183J	Bulletin 1746 SLC 500 Programmable Controller (PLC) I/O Chassis with circuit breaker
2180L	Bulletin 1756 ControlLogix Programmable Controller (PLC) I/O Chassis without Disconnecting Means <sup>[1]</sup>
2182L	Bulletin 1756 ControlLogix Programmable Controller (PLC) I/O Chassis with Fusible Disconnect <sup>[1]</sup>
2183L	Bulletin 1756 ControlLogix Programmable Controller (PLC) I/O Chassis with Circuit Breaker <sup>[1]</sup>

Code	NEMA Enclosure Type
K	NEMA Type 1 or Type 1 with gasket
J	NEMA Type 12

Code	Line Voltage
P	220 - 230V
A	240V
N	380V
KN	400V
I	415V
B	480V
C	600V
XWD	120V

Does not include transformer or power bus stabs

Code	Option
	See Options section beginning on page 203.

Code	Number of I/O Chassis and Slots
A	(1) 4-slot chassis
B	(1) 7-slot chassis (Bulletins 2180J, 2182J and 2183J and Bulletins 2180L, 2182L and 2183L)
B	(1) 8-slot chassis (Bulletins 2180E, 2182E and 2183E)
C	(1) 8-slot chassis 25" (635 mm) wide full section
D	(2) 8-slot chassis 25" (635 mm) wide full section
E	(1) 16-slot chassis 35" (889 mm) wide full section
F	(2) 16-slot chassis 35" (889 mm) wide full section
G	(1) 16-slot chassis 40" (1016 mm) wide full section
H	(2) 16-slot chassis 40" (1016 mm) wide full section
J	(3) 16-slot chassis 40" (1016 mm) wide full section

Code	Trip Current and Circuit Breaker Type
Bulletin 2183_Only	See Table on page 199

[1] 2180LB, 2182LB and 2183LB indicate bottom mounting on section.

## Programmable Controller Units and Marshalling Panels

### Units—2180E, 2182E, 2183E

#### Bulletin 1771 Programmable Controller I/O Chassis (PLC)

- See 195 for product description.
- All programmable control I/O chassis plug-in units must be located in the bottom of the vertical section to retain UL listing.

265

Bulletin	I/O Chassis		Space Factor	Section Width (inches)	Catalog Number <sup>[1]</sup> Wiring Type A Only - Class I		Delivery Program
	Chassis Quantity	Chassis Size			NEMA Type 1 and Type 1 w/ gasket	NEMA Type 12	
2180E  Basic I/O chassis without disconnecting means, transformer, or plug-in stabs	1	4 slot	2.0	—	2180E-AKXWD	2180E-AJXWD	PE
	1	8 slot	2.0	—	2180E-BKXWD	2180E-BJXWD	
	1	8 slot	6.0 <sup>[2]</sup>	25"	2180E-CKXWD	2180E-CJXWD	PE-II
	2	8 slot	6.0 <sup>[2]</sup>	25"	2180E-DKXWD	2180E-DJXWD	
	1	16 slot	6.0 <sup>[2]</sup> , <sup>[4]</sup>	35"	2180E-EKXWD	2180E-EJXWD	
	2	16 slot			2180E-FKXWD	2180E-FJXWD	
	1 <sup>[3]</sup>	16 slot	6.0 <sup>[2]</sup> , <sup>[4]</sup>	40" wide 20" deep <sup>[5]</sup>	2180E-GKXWD	2180E-GJXWD	
	2 <sup>[3]</sup>	16 slot			2180E-HKXWD	2180E-HJXWD	
3 <sup>[3]</sup>	16 slot	2180E-JKXWD			2180E-JJXWD		
2182E  Basic I/O chassis with disconnect and transformer <sup>[1]</sup>	1	4 slot	2.0	—	2182E-AK__	2182E-AJ__	PE
	1	8 slot	2.5 <sup>[7]</sup>	—	2182E-BK__	2182E-BJ__	
	1	8 slot	6.0 <sup>[2]</sup>	25"	2182E-CK__	2182E-CJ__	PE-II
	2	8 slot	6.0 <sup>[2]</sup>	25"	2182E-DK__	2182E-DJ__	
	1	16 slot	6.0 <sup>[2]</sup> , <sup>[4]</sup>	35"	2182E-EK__	2182E-EJ__	
	2	16 slot			2182E-FK__	2182E-FJ__	
	1 <sup>[6]</sup>	16 slot	6.0 <sup>[2]</sup> , <sup>[4]</sup>	40" wide 20" deep <sup>[5]</sup>	2182E-GK__	2182E-GJ__	
2 <sup>[6]</sup>	16 slot	2182E-HK__			2182E-HJ__		
2183E  Basic I/O chassis with circuit breaker and transformer <sup>[1]</sup>	1	4 slot	2.0	—	2183E-AK__-30__	2183E-AJ__-30__	PE
	1	8 slot	2.5 <sup>[7]</sup>	—	2183E-BK__-30__	2183E-BJ__-30__	
	1	8 slot	6.0 <sup>[2]</sup>	25"	2183E-CK__-30__	2183E-CJ__-30__	PE-II
	2	8 slot	6.0 <sup>[2]</sup>	25"	2183E-DK__-32__	2183E-DJ__-32__	
	1	16 slot	6.0 <sup>[2]</sup> , <sup>[4]</sup>	35"	2183E-EK__-32__	2183E-EJ__-32__	
	2	16 slot			2183E-FK__-32__	2183E-FJ__-32__	
	1 <sup>[6]</sup>	16 slot	6.0 <sup>[2]</sup> , <sup>[4]</sup>	40" wide 20" deep <sup>[5]</sup>	2183E-GK__-32__	2183E-GJ__-32__	
	2 <sup>[6]</sup>	16 slot			2183E-HK__-32__	2183E-HJ__-32__	

[1] Catalog numbers listed are not complete for Bulletins 2182E and 2183E:

- Select the appropriate voltage code from table on page 199 to identify the control transformer primary voltage.
- For Bulletin 2183E, also select the appropriate circuit breaker suffix from table on page 199 to identify the circuit breaker type (e.g., 2183E-AKB-30**CB**).

[2] Frame mounted unit, section does not have vertical wireway.

[3] If one (1) chassis is selected, it will be located in the middle.  
If two (2) chassis are selected, they will be located at the top and the middle.  
If three (3) chassis are selected, they will be located at the top, middle and bottom.

[4] Not available in NEMA Type 3R or Type 4.

[5] 40" wide sections have two doors. Horizontal bus is 5" deeper than standard. Available 15" deep without horizontal bus. Rear access needed for splicing power bus.

[6] If one (1) chassis is selected, it will be located in the middle, directly below the disconnecting means panel.

[7] If two (2) chassis are selected, they will be located at the middle (directly below the disconnecting means panel) and at the bottom.

[7] Not UL listed or CSA certified.

- See 195 for product description.

266

Bulletin	I/O Chassis		Space Factor	Catalog Number <sup>[1]</sup> Wiring Type A Only - Class I		Delivery Program
	Chassis Quantity	Chassis Size		NEMA Type 1 and Type 1 w/ gasket	NEMA Type 12	
2180J <sup>[2]</sup> Basic I/O chassis without disconnecting means or plug-in stabs	1	7 slot	1.0	2180J-BKXWD	2180J-BJXWD	PE
2182J <sup>[2]</sup> Basic I/O chassis with disconnect and transformer	1	7 slot	1.5	2182J-BK__	2182J-BJ__	
2183J <sup>[2]</sup> Basic I/O chassis with circuit breaker and transformer	1	7 slot	1.5	2183J-BK__-30__	2183J-BJ-30__	

[1] Catalog numbers listed are not complete for Bulletins 2182J and 2183J:

- Select the appropriate voltage code from table to identify the control transformer primary voltage (e.g., 2182J-BKB).
- For Bulletin 2183J, also select the suffix letter from table to identify the circuit breaker type (e.g., 2183J-BKB-30CB).

[2] A power supply must be selected for all 2180J, 2182J and 2183J units. Refer to power supply options on page 203.

**Primary Voltage for Transformer**

267

Primary Voltage	Voltage Code
220/230	P
240	A
380	N
400	KN
415	I
480	B
600	C

**Circuit Breaker Options and Adders (for combination short circuit withstand ratings, see page 238) \***

268

Circuit Breaker Frame Type	Suffix
I3C	CB
I6C	CM
I3C-CL	CD <sup>[1]</sup>

[1] Available on Bulletin 2183E only.

\* Refer to publication 2100-TD002.x-EN-P, *CENTERLINE Motor Control Centers Thermal Magnetic Circuit Breakers*, for more information.

## Programmable Controller Units and Marshalling Panels

### Units—2180L, 2182L, 2183L

Bulletin 1756 ControlLogix Programmable Controller (PLC)

- See 196 for product description.

269

Bulletin	I/O Chassis		Space Factor	Catalog Number <sup>[1]</sup> Wiring Type A Only - Class I		Delivery Program
	Chassis Quantity	Chassis Size		NEMA Type 1 and Type 1 w/ gasket	NEMA Type 12	
2180L <sup>[2]</sup> Basic I/O chassis without disconnecting means or plug-in stabs. Includes viewing window.	1	4 slot	1.0	2180L-AKXWD	2180L-AJXWD	SC
	1	7 slot	2.0 <sup>[3]</sup>	2180LB-BKXWD	2180LB-BJXWD	SC-II
2182L <sup>[2]</sup> Basic I/O chassis with disconnect and transformer. Includes viewing window.	1	4 slot	1.5	2182L-AK__	2182L-AJ__	SC
	1	7 slot	2.0 <sup>[3]</sup>	2182LB-BK__	2182LB-BJ__	SC-II
2183L <sup>[2]</sup> Basic I/O chassis with circuit breaker and transformer. Includes viewing window.	1	4 slot	1.5	2183L-AK_-30__	2182L-AJ_-30__	SC
	1	7 slot	2.0 <sup>[3]</sup>	2183LB-BK_-30__	2183LB-BJ_-30__	SC-II

[1] Catalog numbers listed are not complete:

- Select appropriate voltage code from the table on page 199 to identify the control transformer primary voltage (e.g., 2182L-BK**B**).
- For Bulletin 2183L, also select the suffix letter from the table on page 199 to identify the circuit breaker type (e.g., 2183L-BKB-30**CB**).

[2] A power supply must be selected for all 2180L, 2182L and 2183L units. Refer to the Options table on page 203.

[3] Frame mounted unit, section does not have vertical wireway next to this unit. Must be mounted at bottom of section. Cannot be used in section with 9" vertical wireway. May not be mounted in a section containing other frame mounted units.

## Catalog Number Explanation - Bulletin 2181B

### Marshalling Panels

- Type A wiring, NEMA Enclosure Type 1, Type 1 with gasket or Type 12
- Wire ducts included

270

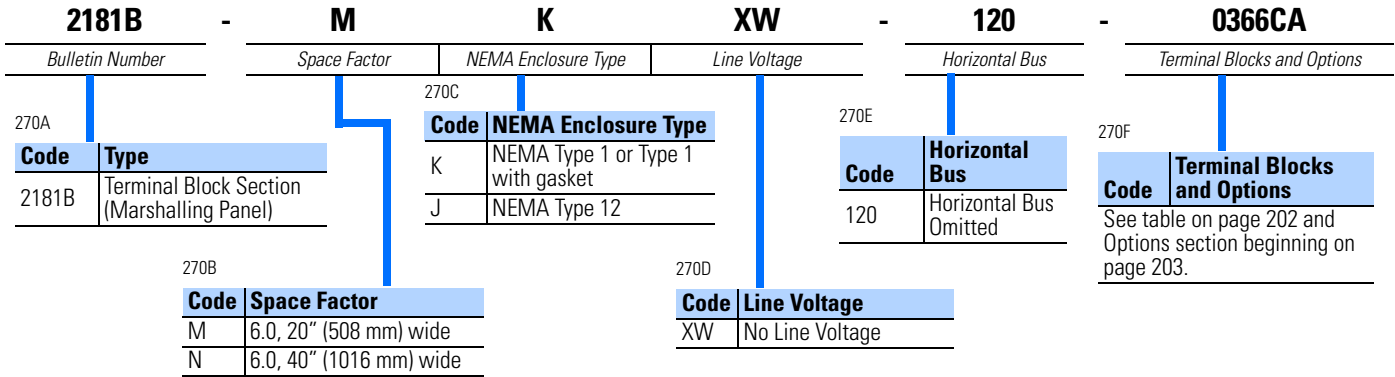

## Programmable Controller Units and Marshalling Panels

### Units—2181B

#### Marshalling Panel

- See 196 for product description.

271

Bulletin	Space Factor	Section Width (Inches)	Catalog Number <sup>[1]</sup> (Wiring Type A Only)		Delivery Program
			NEMA Type 1 and Type 1 w/ gasket	NEMA Type 12	
2181B Marshalling Panel	6.0	20" full section	2181B-MKXW-120-__	2181B-MJXW-120-__	PE-II
	6.0	40" full section	2181B-NKXW-120-__	2181B-NJXW-120-__	

[1] Catalog numbers listed are not complete. Select the terminal block code from the table below that corresponds to the required number of terminal blocks (e.g., 2181B-NAXW-120-1550HM1).

#### Terminal Blocks (Unwired) for Marshalling Panels and Terminal Blocks

272

Terminal Block Type	Number of Terminal Blocks	Space Factors	Terminal Block Code
1492-CA1	366	6.0, 20" wide	0366CA
	915	6.0, 40" wide	0915CA
1492-HM1	620	6.0, 20" wide	0620HM1
	1550	6.0, 40" wide	1550HM1

# Factory-Installed Options, Modifications, Accessories for Programmable Controllers and Marshalling Panels

Multiple option numbers are separated by a dash and added to the base catalog number in ascending order.

273

Option	Option Number	Description	Bulletin 1771 I/O Chassis			Bulletin 1746 SLC 500			Bulletin 1756 ControlLogix Chassis			Delivery Program
			2180E	2182E	2183E	2180J	2182J	2183J	2180L	2182L	2183L	
DeviceNet Scanner Module	-12SDN01	DeviceNet scanner module	1771-SDN	✓	✓	✓						PE
			1747-SDN				✓	✓	✓			
	-12P2 [2]	Bulletin 1771-P2, 6.5A power supply and 1771-CE (4-slot chassis) or 1771-CD (8- or 16-slot chassis) power cable	For (1) 4-slot, (1) 8-slot, or (1) 16-slot [3]	✓	✓	✓						
			For (2) 8-slot or for (2) 16-slot	✓	✓	✓						
	-12P4S1 [4]	Bulletin 1771-P4S, 8.0A power supply. One power supply per chassis is required. A maximum of two power supplies per chassis can be selected. <b>Note:</b> One chassis slot is necessary for each power supply.	One 1771-P4S power supply	✓	✓	✓						
			Two 1771-P4S power supplies (for one chassis) and one 1771-CT paralleling cable	✓	✓	✓						
	-12P4R2 [4]	Bulletin 1771-P4R, 8.0A power supply. This is a redundant power supply and requires two supplies to operate. Up to four power supplies per chassis can be selected. <b>Note:</b> One chassis slot is necessary for each power supply.	Two 1771-P4R Power Supplies (for one chassis)	✓	✓	✓						
			Three 1771-P4R Power Supplies (for one chassis) – 16-slot chassis only	✓	✓	✓						
	-12P4R3 [4]	Bulletin 1771-P4R, 8.0A power supply. This is a redundant power supply and requires two supplies to operate. Up to four power supplies per chassis can be selected. <b>Note:</b> One chassis slot is necessary for each power supply.	Four 1771-P4R Power Supplies (for one chassis) – 16-slot chassis only	✓	✓	✓						
			Four 1771-P4R Power Supplies (for one chassis) – 16-slot chassis only	✓	✓	✓						
	-12P7	Bulletin 1771-P7, 16A power supply and 1771-CP2 power cable. <b>Note:</b> Does not mount in chassis slot. Not available for plug-in units.	For (1) 8-slot or 16-slot	✓	✓	✓						
			For (2) 8-slot or for (2) 16-slot	✓	✓	✓						
-12PA [5]	One (1) Bulletin 1746-P1, 2.0A power supply						✓	✓	✓			
-12PB [5]	One (1) Bulletin 1746-P2, 5.0A power supply						✓					
-12PA72	Bulletin 1756-PA72, 10.0A power supply for 4- and 7-slot ControlLogix chassis								✓	✓	✓	
ControlLogix Processor [6]	-12LPA_	Logix5561 Processor With 2Mbyte Memory, includes 1784-CF64 64Mbyte CompactFlash memory module							✓	✓	✓	
	-12LPB_	Logix5562 Processor With 4Mbyte Memory, includes 1784-CF64 64Mbyte CompactFlash memory module							✓	✓	✓	
	-12LPC_	Logix5563 Processor With 8Mbyte Memory, includes 1784-CF64 64Mbyte CompactFlash memory module							✓	✓	✓	
	-12LPD_	Logix5564 Processor With 16Mbyte Memory, includes 1784-CF64 64Mbyte CompactFlash memory module							✓	✓	✓	
ControlLogix Communication Modules [6]	-12CN_ [2],[7]	Bulletin 1756-CNBR ControlNet communication module with redundant ControlNet port							✓	✓	✓	
	-12ENB_ [2]	Bulletin 1756-ENBT Ethernet communication module							✓	✓	✓	
	-12DN_ [2]	Bulletin 1756-DNB DeviceNet communication module							✓	✓	✓	
	-12DH_ [2]	Bulletin 1756-DHRIO Data Highway Plus and Remote I/O communication module							✓	✓	✓	
ControlLogix Programming Cable	-12CP	Bulletin 1756-CP3 cable for programming ControlLogix processors							✓	✓	✓	
ControlNet T-Tap	-12CNT_ [7]	Bulletin 1786 ControlNet T-Tap for use with ControlNet Communication Modules							✓	✓	✓	
Grounded Unit Door	-79GD	Hinge mounted ground strap mounted on hinge of unit door. (Unit door grounding strap for IEC requirements.)	✓	✓	✓	✓	✓	✓	✓	✓	✓	
	—	Select on plug-in units for sections with vertical plug-in ground bus. Unplated copper unit ground stab can also be used with steel vertical ground bus.	✓	✓	✓	✓	✓	✓	✓	✓	✓	
	-79UT		✓	✓	✓	✓	✓	✓	✓	✓		
Unit Ground Stab	—		✓	✓	✓	✓	✓	✓	✓	✓		
	-79U		✓	✓	✓	✓	✓	✓	✓	✓		
	-79UT		✓	✓	✓	✓	✓	✓	✓	✓		
	—		✓	✓	✓	✓	✓	✓	✓	✓		
Auxiliary Contacts	-98 [8]	<b>Normally Open</b> —(1) N.O. mounted on operating mechanism (operates with movement of external handle only)	✓	✓	✓			✓		✓		
	-98X [9]	<b>Normally Open</b> —(1) N.O. mounted internally	✓	✓	✓			✓		✓		
	-99 [8]	<b>Normally Closed</b> —(1) N.C. mounted on operating mechanism (operates with movement of external handle only)		✓			✓		✓			
	-99X [9]	<b>Normally Closed</b> —(1) N.C. mounted internally		✓			✓		✓			

[1] Power supply options are mutually exclusive.  
 [2] 2182E or 2183E 4-slot with 12P2: add 1.0 space factor. 2180E 8-slot with 12P2: add 1.0 space factor. 2182E or 2183E 8-slot with 12P2: add 1.0 space factor.  
 [3] Not available in 40" wide units.  
 [4] UL listing and CSA certification only valid for 6.0 space factor units.  
 [5] Option is NOT CSA certified.  
 [6] Option numbers are not complete. Add the number of chassis slot the option is to be mounted in (e.g., a 12LPA\_ located in slot 0 will be 12LPA0 and a 12ENB\_ located in slot 3 will be 12ENB3). Multiple quantities of the same option may be mounted in the same chassis (e.g., a 7-slot chassis may contain two [2] processor cards, two [2] ethernet cards, one [1] ControlNet card and two DeviceNet cards).  
 [7] Option 12CNT\_, Bulletin 1786 ControlNet T-Tap, is available for use with option 12CN\_ for connection to ControlNet scheme. See publication CNET-IN002x-EN-P, *ControlNet Coax Media Planning and Installation Guide*, for cabling configuration. Option number not complete. Add the corresponding slot number for the associated 12CN\_. Option -12CNT\_ is not available alone.  
 [8] The maximum number of auxiliary contacts that can be supplied is two (2), in any combination. Contacts actuate with movement of unit handle to ON or OFF position only. Contacts are not designed to actuate as a result of a circuit breaker trip. For such applications, auxiliary contacts mounted internally (98X or 99X) must be selected. Auxiliary contacts are supplied unwired.  
 [9] The maximum number of auxiliary contacts that can be supplied internally is two (2). These are form C contacts. Each form C contact includes one N.O. and one N.C. contact. Internal auxiliary contacts (98X or 99X) are wired to a 3-point unmounted terminal block.

## Factory-Installed Options, Modifications, Accessories for Programmable Controllers and Marshalling Panels

Multiple option numbers are separated by a dash and added to the base catalog number in ascending order.

274

Option	Option Number	Description	Bulletin 1771 I/O Chassis			Bulletin 1746 SLC 500			Bulletin 1756 ControlLogix Chassis			Marshalling Panel	Delivery Program	
			2180E	2182E	2183E	2180J	2182J	2183J	2180L	2182L	2183L	2181B		
T-Handle	-111	T-Handle latches on unit door		✓	✓		✓	✓	✓	✓	✓			
Omit Horizontal Power Bus	-120 [1]	Available on 15" and 20" deep × 25" and 35" wide or on 20" deep × 40" wide	✓	✓	✓							✓	SC	
Light and Door Switch	-203B	Section is supplied with a top-mounted light that is activated by a door switch. <b>Note:</b> Only available on 40" wide 2180E, 2181B, 2182E and 2183E.	✓	✓	✓							✓	PE	
Control Wire Markers	-751D	Adhesive Brady Datab type markers at each end of control wire. Not available in Canada.	✓ [2]	✓	✓		✓	✓		✓	✓		SC	
	-751HS	Heat shrink type wire marker	✓ [2]	✓	✓		✓	✓		✓	✓		SC (+2 days)	
	-751S	Sleeve type wire marker	✓ [2]	✓	✓		✓	✓		✓	✓		SC	
Terminal Blocks (unwired) for chassis in full sections only [3]	-806	For (1) 8-slot chassis, 25" wide (100 terminals)	✓	✓	✓								PE	
		For (2) 8-slot chassis, 25" wide (200 terminals)	✓	✓	✓									
		For (1) 16-slot chassis, 35" wide (150 terminals)	✓	✓	✓									
		For (2) 16-slot chassis, 35" wide (300 terminals)	✓	✓	✓									
	Bulletin 1492-HM1 Terminal Blocks (white only)	For (1) 16-slot chassis, no disconnecting means, 40" wide (180 terminals)	✓											
		For (2) 16-slot chassis, no disconnecting means, 40" wide (360 terminals)	✓											
		For (3) 16-slot chassis, no disconnecting means, 40" wide (540 terminals)	✓											
		For (1) 16-slot chassis, with disconnecting means, 40" wide (360 terminals)		✓	✓									
	-807	For (2) 16-slot chassis, with disconnecting means, 40" wide (720 terminals)		✓	✓									
		For (1) 8-slot chassis, 25" wide (87 terminals)	✓	✓	✓									
		For (2) 8-slot chassis, 25" wide (174 terminals)	✓	✓	✓									
		For (1) 16-slot chassis, 35" wide (135 terminals)	✓	✓	✓									
		For (2) 16-slot chassis, 35" wide (270 terminals)	✓	✓	✓									
		For (1) 16-slot chassis, no disconnecting means, 40" wide (108 terminals)	✓											
		For (2) 16-slot chassis, no disconnecting means, 40" wide (216 terminals)	✓											
		For (3) 16-slot chassis, no disconnecting means, 40" wide (324 terminals)	✓											
Bulletin 1492-CA1 Terminal Blocks (white only)	For (1) 16-slot chassis, with disconnecting means, 40" wide (216 terminals)		✓	✓										
	For (2) 16-slot chassis, with disconnecting means, 40" wide (432 terminals)		✓	✓										
Unit Door Nameplates	—	Door Nameplate Screws	Plated steel nameplate screws. Provided when cardholder or nameplates are not selected.	✓	✓	✓	✓	✓	✓	✓	✓	✓	SC	
		Card Holder for Unit Doors	1.125" x 3.625" plastic card holders with blank cards	✓	✓	✓	✓	✓	✓	✓	✓	✓		
	—	1.125" x 3.625" engraved 3-line nameplate or 4-line nameplate	Acrylic plate (available in U.S. only). Lettering is white with black letters or black with white letters.	✓	✓	✓	✓	✓	✓	✓	✓	✓	SC-II	
			Phenolic plate. Lettering is white with black letters or black with white letters.	✓	✓	✓	✓	✓	✓	✓	✓	✓		
Stainless Steel Nameplate Screws	—	Stainless steel nameplate screws for unit nameplate (2 per unit)	✓	✓	✓	✓	✓	✓	✓	✓	✓			
Export Packing Below Deck	—	Container is skid mounted and packaged in clear plastic. Packing is not watertight or waterproof. Considerations should be taken if extended storage is expected.	✓	✓	✓	✓	✓	✓	✓	✓	✓	✓	SC (+2 days)	

[1] Enclosures with horizontal power bus omission are listed under UL Standard 508.

[2] Only available for 2180E when option -203B is selected.

[3] Options 806 and 807 are mutually exclusive.

# Configuration Tables

## Control Voltage Type for Bulletins 2102L, 2103L, 2106, 2107, 2112, 2113, 2122, 2123, 2126, and 2127

275

Control Voltage Code							Control Type
208V	240V	380V	400V	415V	480V	600V	
H	A	—	—	—	B	C	120V, 60Hz, Transformer Control <sup>[1]</sup>
HD	AD	—	—	—	BD	CD	120V, 60Hz, Separate Control <sup>[2]</sup>
—	—	N	—	I	—	—	110V, 50Hz, Transformer Control <sup>[1],[3]</sup>
—	—	NS	—	IS	—	—	110V, 50Hz, Separate Control <sup>[2]</sup>
—	—	—	KN	—	—	—	115V, 50Hz, Transformer Control <sup>[1],[3]</sup>
—	—	—	KNS	—	—	—	115V, 50Hz, Separate Control <sup>[2]</sup>
—	—	NP	—	—	—	—	220V, 50Hz, Transformer Control <sup>[1],[3]</sup>
—	—	NP	—	—	—	—	220V, 50Hz, Separate Control <sup>[2]</sup>
—	—	—	KNP	—	—	—	230V, 50Hz, Transformer Control <sup>[1],[3]</sup>
—	—	—	KNP	—	—	—	230V, 50Hz, Separate Control <sup>[2]</sup>
—	—	—	—	IT	—	—	240V, 50Hz, Transformer Control <sup>[1],[3]</sup>
—	—	—	—	IT	—	—	240V, 50Hz, Separate Control <sup>[2]</sup>
—	—	NLP	—	—	—	—	220V, 50Hz, Line to Neutral Control, (Separate Control) <sup>[4],[5]</sup>
—	—	—	KNLP	—	—	—	230V, 50Hz, Line to Neutral Control, (Separate Control) <sup>[4],[5]</sup>
—	—	—	—	ILT	—	—	240V, 50Hz, Line to Neutral Control, (Separate Control) <sup>[4],[5]</sup>
H	A	—	—	—	B	C	Common Control <sup>[6]</sup>

[1] Select a control circuit transformer. See Options section.

[2] Control circuit fusing (option 21) and/or disconnect interlock (option 98) may be required to comply with NEC. See Options section.

[3] Incorporates primary taps for future conversion to new global IEC voltage standards (e.g., 400V/115V/230V). Allows conversion without the need to replace transformers or coils.

[4] Requires horizontal neutral bus and vertical neutral bus in 9" vertical wireway. Refer to Section Modifications to select.

[5] Select control circuit fusing (see option 21 in Options section).

[6] Select control circuit fusing (see option 22 in Options section). Required to comply with NEC.

## Control Voltage Type for Space Saving NEMA Bulletins 2106, 2107, 2112 and 2113

276

Control Voltage Code		Control Type
480V	600V	
B	C	120V, 60Hz, Transformer Control <sup>[1]</sup>
BD	CD	120V, 60Hz, Separate Control <sup>[2]</sup>

[1] Select a control circuit transformer. See Options section.

[2] Control circuit fusing (option 21) and/or disconnect interlock (option 98) may be required to comply with NEC. See Options section.

## Primary Voltage Code for Bulletins 2195, 2196, 2196Z, 2197 and 2197Z

277

240V	380V	400V	415V	480V	600V
A	N	KN	I	B	C

## Control Voltage Type for Bulletins 2154 and 2155

278

Control Voltage Code								Control Type
220V <sup>[1]</sup>	230V <sup>[1]</sup>	240V	380V <sup>[1]</sup>	400V <sup>[1]</sup>	415V <sup>[1]</sup>	480V	600V	
P	—	—	N	—	I	—	—	110V, 50Hz Transformer Control
—	P	—	—	KN	—	—	—	115V, 50Hz Transformer Control
—	—	A	—	—	—	B	C	120V, 60Hz Transformer Control

[1] Units at these voltages are not UL listed, cUL listed or CSA certified.

**Configuration Tables**

**Control Voltage Type for Bulletins 2162, 2163, 2164 and 2165**

279

Line Voltage	Voltage Code
220/230	P <sup>[1],[2]</sup>
240	A <sup>[2]</sup>
380	N <sup>[1],[2]</sup>
400	KN <sup>[1],[2]</sup>
415	J <sup>[1],[2]</sup>
480	B
600	C

[1] Units at these voltages are not UL listed or CSA certified.

[2] Not applicable to 2164 or 2165.

**Horsepower Ratings for All Bulletins**

280

Motor HP	Number	Motor HP	Number	Motor HP	Number	Motor HP	Number
0.125	30	3	38	40	46	250	56
0.25	31	5	39	50	47	300	57
0.33	32	7.5	40	60	48	350	58
0.50	33	10	41	75	49	400	59
0.75	34	15	42	100	50		
1	35	20	43	125	51	450	60
1.5	36	25	44	150	52	500	61
2	37	30	45	200	54		

**kW Ratings for Bulletins 2154, 2155, 2162 and 2163 <sup>[1]</sup>**

281

kW	Number	kW	Number
0.25	32K	37	47K
0.37	33K	45	48K
0.55	34K	55	49K
0.75	35K	75	50K
1.1	36K	90	51K
1.5	37K	110	52K
2.2	38K	132	53K
3.7	39K	150	54K
5.5	40K	160	55K
7.5	41K	185	56K
11	42K	200	57K
15	43K	220	58K
18.5	44K	250	59K
22	45K		
30	46K		

[1] kW rated units are not UL listed, cUL listed or CSA certified.

**Fuse Clip Designator Selection, Power Fuse Selection for Bulletins 2106, 2112, 2122, and 2126**

Fuse Clip Rating (Amperes)	Fuse Clip Type	To select Fuse Clip Designator, select code from one of these two columns.		To select Power Fuses, select power fuse manufacturer code from these columns [1],[2].		
		When NO power fuses will be selected, select fuse clip designator from this column.	When power fuses will be selected, select fuse clip designator from this column [1],[2]. The "20" portion of your Fuse Clip Designator (e.g., 20J) means that the fuse clip size and power fuse will be selected automatically based on load horsepower. [3],[4]	Power Fuse Manufacturer Code [5]		
				Typical (T) Accel. Time ≤ 5 sec.	Long (L) Accel. Time > 5 sec.	Fuse Class [2]
30	CC	24C	20C	LT	LL	CC
30	J	24J	20J	GT or BT	GL or BL	J
	R	24R	20R			R
	H [1]	24	—			—
	HRCII-C [6]	24E	20E			HRCII-C
60	J	25J	20J	GT or BT	GL or BL	J
	R	25R	20R			R
	H [1]	25	—			—
	HRCII-C [6]	25E	20E			HRCII-C
100	J	26J	20J	GT or BT	GL or BL	J
	R	26R	20R			R
	H [1]	26	—			—
	HRCII-C [6]	26E	20E			HRCII-C
200	J	27J	20J	GT or BT	GL or BL	J
	R	27R	20R			R
	H [1]	27	—			—
	HRCII-C [6]	27E	20E			HRCII-C
400	J	28J	20J	GT or BT	GL or BL	J
	R	28R	20R			R
	H [1]	28	—			—
	HRCII-C [6]	28E	20E			HRCII-C
600	J	29J	20J	GT or BT	GL or BL	J
	R	29R	20R			R
	HRCII-C [6]	29E	20E			HRCII-C
800	L	24L	20L	GT or BT	GL or BL	L

[1] Power fuse option not available for Class H fuse clips or Space Saving NEMA starter units.  
 [2] Available on 480V and 600V applications only.  
 • To select power fuses for Bulletins 2106, 2112, 2122, and 2126:  
 • Select fuse clip designator and add to catalog string number (e.g., 2106B-BABD-31\_\_-20J).  
 • Then select power fuse manufacturer code and add to catalog string number (e.g., 2106B-BABD-31GT-20J). Only use power fuse code when selecting power fuses.  
 [3] For Bulletins 2100D, 2102L, 2192F and 2192M, see table on page 208. For Bulletin 2196, see 209.  
 [4] Refer to publication 2100-TD003x-EN-P, *CENTERLINE Motor Control Centers Power Fuses*, for more information.  
 [5] Select power fuse manufacturer code by indicating choice of power fuse manufacturer—LT or LL = Littelfuse, GT or GL = Ferraz Shawmut, and BT or BL = Bussmann. When selecting Bussmann or Littelfuse, delivery program changes to PE. The Ferraz Shawmut Class J fuse incorporates blown fuse indication for fuses above 8A.  
 [6] HRCII-C fuses are available in Canada only. HRCII-C Bussmann (BT or BL) fuses are not available; use HRCII-C Ferraz Shawmut (option code GT or GL). They are CSA certified but are NOT UL listed.

Fuse Clip Designator Selection, Power Fuse Selection for Bulletins 2100D, 2102L, 2192F and 2192M <sup>\*,†</sup>

Use this information to select a fuse clip designator.			Use this information to select power fuses. <sup>[1],[2]</sup>			
Fuse Clip Rating (Amperes)	Fuse Clip Class	Fuse Clip Designator	Power Fuse Rating (Amperes)	Power Fuse Rating Code	Power Fuse Manufacturer <sup>[3]</sup>	Fuse Class
30	CC	24C	1	600	L <sup>[4]</sup>	CC
			3	601		
			6	602		
			10	603		
			15	604		
			20	605		
			25	606		
	30	607				
	J R H <sup>[1]</sup>	24J 24R 24	1	600		
			3	601		
			6	602		
			10	603		
			15	604		
			20	605		
25			606			
60	J R H <sup>[1]</sup>	25J 25R 25	35	608		
			40	609		
			45	610		
			50	611		
			60	612		
100	J R H <sup>[1]</sup>	26J 26R 26	70	613		
			80	614		
			90	615		
			100	616		
200	J R H <sup>[1]</sup>	27J 27R 27	110	617		
			125	618		
			150	619		
			175	620		
			200	621		
400	J R H <sup>[1]</sup>	28J 28R 28	225	622		
			250	623		
			300	624		
			350	625		
			400	626		
600	J R H <sup>[1]</sup> L	29J 29R 29 23L <sup>[5]</sup>	450	627		
			500	628		
			600	629		
			601	630		
800	L	24L	601	630		
			700	631		
			800	632		
1200	L	25L	1000	633		
			1200	634		
1600	L	26L	1600	637		
2000	L	27L	2000	639		

[1] Power fuse option is not available for Class H fuse clips.

[2] Available on 480V and 600V applications only. To select power fuses for Bulletins 2100D, 2102L, 2192F and 2192M, combine power fuse rating code and power fuse manufacturer code and add to catalog string number (e.g., 2102LB-BKBD-24J-607G). Only use power fuse code when selecting power fuses. Dual 2192F units require two (2) sets of fuses. The fuse size code must correspond to the respective fuse clip designator code; the first fuse size code designates the fuse for the left side of the dual unit, the second code is for the right side of the dual unit. The fuse manufacturer for both fuses must be the same (e.g., 2192F-CAC-2524J-609602G).

[3] L = Littelfuse, G = Ferraz Shawmut, B = Bussmann. The Ferraz Shawmut Class J fuse incorporates blown fuse indication for fuses above 8A.

[4] When selecting Bussmann or Littelfuse power fuses, delivery program changes to PE. Littelfuse power fuses are available only in Class CC fuses with blown fuse indicators.

[5] Available: G = Ferraz Shawmut, 601A only.

\* For Bulletins 2106, 2112, 2122, 2126, and 2154, see table on page 207. For Bulletin 2196, see 209.

† Refer to publication 2100-TD003x-EN-P, *CENTERLINE Motor Control Centers Power Fuses*, for more information.

**Fuse Clip Designator for Bulletin 2196 and 2196Z** <sup>[1]</sup> <sup>[2]</sup>

284

Fuse Clip Size	Fuse Clip Class	Fuse Clip Designator	Fuse Manufacturer Code <sup>[3]</sup>
30	J	24J	Select G or B
	R	24R	G=Ferraz Shawmut
	H <sup>[4]</sup>	24	B=Bussmann
60	J	25J	Select G or B
	R	25R	G=Ferraz Shawmut
	H <sup>[4]</sup>	25	B=Bussmann
100	J	26J	Select G or B
	R	26R	G=Ferraz Shawmut
	H <sup>[4]</sup>	26	B=Bussmann
200	J	27J	Select G or B
	R	27R	G=Ferraz Shawmut
	H <sup>[4]</sup>	27	B=Bussmann

[1] Only 24J option available for 2196Z units.

[2] See Appendix for short circuit withstand ratings. For fuse rating based upon KVA of transformer, see publication 2100-TD003.x-EN-P. Selecting Bussmann or Littelfuse power fuse changes delivery program to PE. Power fuses are not available for Class H fuse clip. Power fuses are available on 480V and 600V only.

[3] The Ferraz Shawmut Class J fuse incorporates blown fuse indication for fuses above 8A.

[4] Power fuse option not available for Class H fuse clip.

**Trip Current for Bulletin 2103L**

285

Contacting Rating (Amperes)	Trip Current (Amperes)	Number
30 or 60	15	30
	20	31
30, 60, or 100	30	32
60 or 100	40	34
	50	35
	60	36
100, 200, or 300	70	37 <sup>[2]</sup>
	80	38 <sup>[1]</sup>
	90	39 <sup>[2]</sup>
	100	40
200 or 300	125	41
	150	42
	175	43
	200	44
300	225	45
	250	46
	300	48

[1] Available only on 100A contactors.

[2] Available only on 100A and 200A contactors.

**Trip Current for Bulletin 2197 and 2197Z**

286

Trip Current (Amperes)	Number	Trip Current (Amperes)	Number
15	30	70	37
20	31	100	40
30	32	125	41
40	34	150	42
50	35	200	44
60	36	—	—

**Circuit Breaker Type—Inverse Time (Thermal Magnetic) Circuit Breaker Options for Bulletin 2103L<sup>\*,†</sup>**

287

Rating (Amperes)	Standard Interrupting Capacity		Medium Interrupting Capacity with Current Limiter <sup>[1]</sup>		Medium Interrupting Capacity		High Interrupting Capacity	
	Suffix	Frame	Suffix	Frame	Suffix	Frame	Suffix	Frame
30 (0.5 SF)	—	—	—	—	CB	I3C	CM	I6C
30-60	—	—	CD	I3C-CL	CB	I3C	CM	I6C
100	—	—	CD	I3C-CL <sup>[2]</sup>	CB	I3C	CM	I6C
200	CT	JD3D	—	—	—	—	CM	JD6D
300	CT	K3D	—	—	—	—	CM	K6D

[1] Circuit breakers with current limiters are not available on dual mounted units.  
 [2] Add 0.5 space factor.

**Circuit Breaker Type for Bulletin 2113 Vacuum<sup>\*</sup>**

287A

Rating (Amperes)	Inverse Time (Thermal Magnetic or Solid State) Circuit Breakers <sup>[1]</sup>			
	Standard Interrupting Capacity		High Interrupting Capacity	
	Suffix	Frame <sup>[2]</sup>	Suffix	Frame <sup>[2]</sup>
200	CT	JD3D	CM	JD6D
400		JD3D		JD6D
		K3D		K6D
		LD		HLD
600		LD		HLD

[1] Refer to publication 2100-TD002x-EN-P, CENTERLINE Motor Control Centers Thermal Magnetic Circuit Breakers, for more information.  
 [2] Refer to unit selection information on page 45 for circuit breaker frame size correlation to vacuum contactor unit size, horsepower and voltage.

\* Refer to Appendix for interrupting capacity and short circuit withstand rating.  
 † Refer to publication 2100-TD002x-EN-P, CENTERLINE Motor Control Centers Thermal Magnetic Circuit Breakers, for more information.

**Circuit Breaker Type for Bulletins 2107, 2113, 2123, and 2127\***

NEMA Size	Instantaneous Circuit Breakers <sup>[1]</sup> (For motor applications where transient inrush current exceeds 13 times the full load current, contact your local Rockwell Automation Sales Office.)						Inverse Time <sup>[2]</sup> (Thermal Magnetic) Circuit Breakers					
	Standard I.C. <sup>[3]</sup>		High I.C.		High I.C. with Current Limiter <sup>[4]</sup>		Standard I.C.		Medium I.C. with Current Limiter <sup>[4]</sup>		High I.C.	
	Suffix	Frame	Suffix	Frame	Suffix	Frame	Suffix	Frame	Suffix	Frame	Suffix	Frame
1 (0.5 SF)	—	—	CA	MCP	—	—	CB <sup>[5]</sup>	I3C	—	—	CM	I6C
1	CZ	MCP	CA	MCP	CC	MCP-ELC <sup>[6]</sup>		I3C	CD	I3C-CL <sup>[6]</sup>	CM	I6C
2	CZ	MCP	CA	MCP	CC	MCP-ELC <sup>[6]</sup>		I3C	CD	I3C-CL <sup>[6]</sup>	CM	I6C
3	CZ	MCP	CA	MCP	CC <sup>[7]</sup>	MCP-ELC <sup>[8]</sup>		I3C	CD <sup>[7]</sup>	I3C-CL <sup>[8]</sup>	CM	I6C
4	—	—	CA	MCP	CC	MCP-ELC <sup>[9]</sup>	CT	JD3D <sup>[9]</sup>	—	—	CM	JD6D <sup>[9]</sup>
5	—	—	CA CAH <sup>[10]</sup> CA <sup>[11]</sup>	MCP MCP MCP	—	—	CT CTH <sup>[10]</sup> CT <sup>[11]</sup>	JD3D K3D K3D	—	—	CM CMH <sup>[10]</sup> CM <sup>[11]</sup>	JD6D K6D K6D
6	—	—	CA	MCP	—	—	CT	LD	—	—	CM	HLD
6 <sup>[12]</sup>	—	—	—	—	—	—	CT	MDL	—	—	CM	HMDL

[1] Refer to publication 2100-TD001x-EN-P, *CENTERLINE Motor Control Centers MCP Circuit Breakers*, for more information.  
 [2] Refer to publication 2100-TD002x-EN-P, *CENTERLINE Motor Control Centers Thermal Magnetic Circuit Breakers*, for more information.  
 [3] For Bulletins 2107, 2113, 2123E, 2123F, 2127E, 2127F, 2127J, and 2127K: 25kA short circuit withstand rating. CZ is available at 600V only.  
 [4] For Bulletin 2113, circuit breakers with current limiters are not available on dual mounted units or 0.5 space factor units.  
 [5] Medium I.C.  
 [6] For Bulletin 2107, add 0.5 space factor.  
 [7] For Bulletin 2123F, add 0.5 space factor.  
 [8] For Bulletin 2113, add 0.5 space factor. For Bulletin 2113 size 4 requires a minimum 2.5 space factor when option -CT or -CM is selected.  
 [9] Bulletin 2113 with suffix CC, CT or CM requires a minimum of 2.5 space factors.  
 [10] For special applications where higher than normal inrush exists. Substitutes a 400A frame circuit breaker for a 250A frame circuit breaker in Bulletins 2107, 2113, 2123E and 2123F in size 5, 125-150 HP, 480V applications only.  
 [11] 400A frame circuit breaker supplied for 200HP 480V, 150 HP @ 380-415V, 100 HP @240V, 75 HP @ 208V.  
 [12] For Bulletin 2113, for 200HP at 240V or 400HP at 480V, suffix letter identifying circuit breaker must be CT or CM only.

**Circuit Breaker Type for Space Saving NEMA Bulletins 2107 and 2113**

NEMA Size	Instantaneous Circuit Breakers (For motor applications where transient inrush current exceeds 13 times the full load current, contact your local Rockwell Automation Sales Office.)				Inverse Time (Thermal Magnetic) Circuit Breakers			
	High I.C.		Standard I.C.		Medium I.C.		High I.C.	
	Suffix	Frame	Suffix	Frame	Suffix	Frame	Suffix	Frame
1	CA <sup>[1]</sup>	MCP	—	—	CB	I3C	CM	I6C
2			—	—				
3			—	—				
4			CT	JD3D <sup>[2]</sup>	—	—	JD6D <sup>[2]</sup>	

[1] No UL listing for 1.5 - 3HP @ 600V.  
 [2] Requires Size 4 Bulletin 2113 to be 1.5 space factor.

**Inverse Time (Thermal Magnetic) Circuit Breaker Options for Bulletin 2197\***

Rating (Amperes)	Standard I.C.		Med. I.C. w/ Current Limiter		Medium I.C.		High I.C.	
	Suffix	Frame	Suffix	Frame	Suffix	Frame	Suffix	Frame
15-50	—	—	CD	I3C-CL	CB	I3C	CM	I6C
60-100	—	—	CD	I3C-CL	CB	I3C	CM	I6C
125-150	—	—	CD	I3C-CL	CB	I3C	CM	I6C
200	CT	JD3D	—	—	—	—	CM	JD6D

\* Refer to Appendix for interrupting capacity and short circuit withstand rating.

**Circuit Breaker Type for Horsepower and kW Rated Units for Bulletins 2155H and 2155J**

291

Rating (Amperes)	Instantaneous Circuit Breakers <sup>[1]</sup> (For motor applications where transient inrush currents exceed 13 times the full load current, contact your local Rockwell Automation Sales Office.)		Inverse Time (Thermal Magnetic or Electronic) Circuit Breakers <sup>[2]</sup>								
	High I.C.		Standard I.C.		Medium I.C.		High I.C.				
	Suffix	Frame	Suffix	Frame	Suffix	Frame	Suffix	Frame			
3 - 60	CA <sup>[3]</sup>	MCP	CT	—	CB	I3C	CM	I6C			
85				—				I6C <sup>[4]</sup>			
97				JD3D				JD6D			
108				JD3D				I3C	I6C JD6D		
135				MCP MCP				JD3D	—	—	JD6D
180				MCP MCP				JD3D	—	—	JD6D
201				MCP MCP				K3D JD3D K3D	—	—	K6D JD6D K6D
240				MCP				K3D <sup>[5]</sup>	—	—	K6D <sup>[5]</sup>
251				MCP				K3D LD	—	—	K6D HLD
317				MCP				LD	—	—	HLD
360 - 361				MCP				LD	—	—	HLD
480 - 500				MCP <sup>[6]</sup>				LD MDL	—	—	HLD HMDL

[1] Refer to publication 2100-TD001x-EN-P, *CENTERLINE Motor Control Centers MCP Circuit Breakers*, for more information.  
 [2] Refer to publication 2100-TD002x-EN-P, *CENTERLINE Motor Control Centers Thermal Magnetic Circuit Breakers*, for more information.  
 [3] Bulletin 2155J SMC-Flex units with circuit breaker suffix CA requires High Interrupting Capacity fuses (option 13HIC) for 5A to 85A rated units.  
 [4] 30HP maximum at 240V, 50HP maximum at 480V and 600V, 22kW maximum at 220-230V and 37kW maximum at 380-415V.  
 [5] Not available for 75kW at 220-230V  
 [6] Not available at 240V, 350HP maximum at 480V, 450HP maximum at 600V, 132kW maximum at 220-230V and 220kW maximum at 380-415V.

**Circuit Breaker Type for Bulletins 2163Q, 2163R, 2163T, 2165Q and 2165R \***

292

Type	Instantaneous High Interrupting Capacity			Inverse Time (Thermal Magnetic) Standard Interrupting Capacity			Inverse Time (Thermal Magnetic) Medium Interrupting Capacity			Inverse Time (Thermal Magnetic) High Interrupting Capacity			
HP Range	0.5-60	60-150 <sup>[1]</sup>	200	60-150 <sup>[1]</sup>	200	—	0.5-40	50	0.5-40	50-60	60-150 <sup>[1]</sup>	200	—
kW Range	0.25-37	45-75	90	22, 45-75 <sup>[2]</sup>	75-110 <sup>[3]</sup>	132	0.25-22 <sup>[2]</sup>	18.5, 30-37 <sup>[4]</sup>	0.25-22 <sup>[4]</sup>	18.5, 30-37 <sup>[4]</sup>	22, 45-75 <sup>[5]</sup>	75-110 <sup>[3]</sup>	132
Suffix	CA	CA	CA	CT <sup>[6]</sup>	CT	CT <sup>[7]</sup>	CB <sup>[3]</sup>	CB <sup>[3]</sup>	CM <sup>[3]</sup>	CM <sup>[3]</sup>	CM <sup>[6]</sup>	CM	CM <sup>[7]</sup>
Frame	MCP	MCP	MCP	JD3D	K3D	LD	I3C	I3C	I6C	I6C	JD6D	K6D	HLD

[1] 150HP rating for 480V variable torque applications only. 60HP Heavy Duty at 480V.  
 [2] Only available through 15kW at 220-230V.  
 [3] Only available through 30HP at 240V, through 50HP at 480V and through 60HP at 600V.  
 [4] 18.5kW rating is at 220-230V only.  
 [5] 22kW rating is at 220-230V only.  
 [6] Used for 60HP at 480V and 50 hp heavy duty for 480 V Bulletin 2163R.  
 [7] Increases width to 35" on Bulletin 2163R, 132kW drives.

\* Refer to publication 2100-TD002x-EN-P, *CENTERLINE Motor Control Centers Thermal Magnetic Circuit Breakers*, for more information.

# Hardware and Kits

## Section Hardware and Kits for Field Installation

293

Description			Catalog Number	Delivery Program	
Drip Hood <b>NOTE:</b> NEMA Types 1, 1 with gasket and 12 with drip hood fulfill NEMA Type 2 requirements			10" wide	2100H-DH10	SC
			20" wide	2100H-DH20	
			25" wide	2100H-DH25	
			30" wide	2100H-DH30	
			35" wide	2100H-DH35	
			40" wide	2100H-DH40	
Pullbox	12" high x 20" wide	For 15" deep sections	NEMA Type 1 and Type 1 w/gasket	2100H-N2A1	
			NEMA Type 12	2100H-N2J1	
		For 20" deep sections	NEMA Type 1 and Type 1 w/ gasket	2100H-N2A2	
			NEMA Type 12	2100H-N2J2	
	12" high x 25" wide	For 15" deep sections	NEMA Type 1 and Type 1 w/ gasket	2100H-N2AA1	
			NEMA Type 12	2100H-N2AJ1	
	For 20" deep sections	NEMA Type 1 and Type 1 w/ gasket	2100H-N2AA2		
		NEMA Type 12	2100H-N2AJ2		
Top Horizontal Wireway Pan	For locating units with handle interlocks in the topmost space factor of a vertical section	For use on Series A through E vertical sections	NEMA Type 1	2100H-NA4A1	
			NEMA Type 1 w/ gasket and 12	2100H-NA4J1	
		For use on Series F through current series sections	NEMA Type 1	2100H-NA4A2	
			NEMA Type 1 w/ gasket and 12	2100H-NA4J2	
Horizontal Wireway Cover	Covers either top or bottom wireway opening at front of vertical section		For 20" wide vertical section	2100H-NWW20	
			For 25" wide vertical section	2100H-NWW25	
			For 30" wide vertical section	2100H-NWW30	
			For 35" wide vertical section	2100H-NWW35	
			For 40" wide vertical section	2100H-NWW40	
End Closing Plate	Covers both top and bottom horizontal wireway openings and bus opening on one side of vertical section only	For 15" deep sections	NEMA Type 1 and Type 1 w/ gasket	2100H-N3A1	
			NEMA Type 12	2100H-N3J1	
		For 20" deep sections	NEMA Type 1 and Type 1 w/ gasket	2100H-N3A2	
			NEMA Type 12	2100H-N3J2	
Bottom Closing Plate	For 20" wide x 15" deep section			2100H-N1A1	
	For 20" wide x 20" deep section		NEMA Type 1 or Type 1 w/ gasket MCC (Non-gasketed plates)	2100H-N1A2	
	For 15" deep corner section			2100H-N1A1C	
	For 20" deep corner section			2100H-N1A2C	
External Mounting Channel Kits	Two (2) 1.5" x 3" mounting channels for a single section. <b>NOTE:</b> Adding an external mounting channel will add 1.5" to height of section.			For 20" wide vertical section	2100H-NMC1
			For 25" wide vertical section	2100H-NMC2	
			For 30" wide vertical section	2100H-NMC3	
			For 35" wide vertical section	2100H-NMC4	
			For 40" wide vertical section	2100H-NMC7	
			For 15" deep corner section	2100H-NMC5	
	For 20" deep corner section	2100H-NMC6			
Unit Operating Handle Extender	Permits unit operating handle to be located above the NEC 6' 7" handle-to-floor height limitation. Complies with NEC Article 404.8(A) and the UL Standard for Safety UL 845.			2100H-NE1	
Space Heater Kit	200 watt, 120 volt strip heater with thermostat set at 21°C (70°F)			2100H-NH1	
	200 watt, 240 volt strip heater with thermostat set at 21°C (70°F)			2100H-NH2	
Gasketing Kit <sup>[1]</sup>	Gasketing to cover the section perimeter of two (2) 1.0 space factor doors or one (1) 1.5 through 5.0 space factor doors. For units mounted in series A through D sections.			2100H-GJ10	

[1] Cannot be air shipped

Bus Kits, Splices and Bus Isolation Hardware for Field Installation

Description		Catalog Number	Delivery Program
Vertical Wireway Tie Bar	For use on vertical sections series C or later, with or without a vertical wireway. Includes five (5) vertical wireway tie bars. Mounts on right-hand sidesheet for sections with vertical wireway. Mounts on right-hand and/or left-hand sidesheets for sections without vertical wireway.	2100H-WWTB	
Wiring Diagram Holder Kit	For a central location of all wiring diagrams. Includes wiring diagram clip, clip location identification label for outside of section and mounting instructions.	2100H-WDH	
Touch-Up Paint <sup>[1]</sup>	ANSI 49 medium light gray, 12 oz. spray can (cannot be used for NEMA Type 3R enclosures)	2100H-NP1	
Vertical Ground Bus Kit	Contains vertical ground bus, hardware and installation instructions	Zinc plated steel	2100H-GS1
	Contains vertical ground bus, six (6) unit plug-in stabs, hardware and installation instructions	Unplated copper	2100H-N79U
		Tin plated copper	2100H-N79UT
Vertical Unit Load Ground Bus Kit	Contains vertical ground bus, six (6) unit load connectors, hardware and installation instructions	Unplated copper	2100H-N79L
		Tin plated copper	2100H-N79LT
Unit Load Ground Kit	Hardware for connecting unit load ground wires to horizontal ground bus. Kit consists of two, #14 AWG to #4 AWG, lugs and hardware. Horizontal ground bus can accommodate up to six 2100H-UG1 kits.	2100H-UG1	
Horizontal Power Bus Splice Kit	Splice bars, hardware and installation instructions for 3-phase splicing of NEMA Enclosure Type 1, Type 1 with gasket and Type 12 sections. One (1) kit required per shipping split on front mounted lineups, two (2) for back-to-back.	For 600A aluminum, tin plated bus	2100H-NAT06
		For 800A aluminum, tin plated bus	2100H-NAT08
		For 600A copper, tin plated bus	2100H-NCT06
		For 800A copper, tin plated bus	2100H-NCT08
		For 1200A copper, tin plated bus	2100H-NCT12
		For 1600A copper, tin plated bus	2100H-NCT16
	Splice bars, hardware and installation instructions for 3-phase splicing of NEMA Type I, Type I with gasket and Type 12 sections. One of the sections has horizontal power bus 5" deeper than normal (Bumped-back Bus)	For 2000A copper, tin plated bus	2100H-NCT20
		For 600A aluminum, tin plated bus	2100H-ZAT06
		For 800A aluminum, tin plated bus	2100H-ZAT08
		For 600A copper, tin plated bus	2100H-ZCT06
		For 800A copper, tin plated bus	2100H-ZCT08
		For 1200A copper, tin plated bus	2100H-ZCT12
		For 1600A copper, tin plated bus	2100H-ZCT16
		For 2000A copper, tin plated bus	2100H-ZCT20
Horizontal Ground Bus Splice Kit	One (1) splice bar per kit, complete with hardware and installation instructions. One (1) kit required per shipping split on front mounted lineups, two (2) for back-to-back.	For 0.25" x 1" unplated copper bus	2100H-NC1
		For 0.25" x 2" unplated copper bus	2100H-NC2
		For 0.25" x 1" tin plated copper bus	2100H-NTC1
		For 0.25" x 2" tin plated copper bus	2100H-NTC2
NO-OX-ID <sup>[1]</sup>	NO-OX-ID compound for bus bars and plug-in stabs	1-pint can	2100H-N18
		1-ounce tube	2100H-N18T
Neutral Connection Plate Kit <sup>[2]</sup>	0.25" x 2" x 12" copper tin plated bus plate with #6-250 kcmil lug (280A capacity)	Insulated from and mounted on top of horizontal wireway pan.	2100H-NPC1
		Insulated from and mounted to unit support pan for blank unit space. <b>Blank door not included.</b> Select on page 102.	2100H-NPC2
		Insulated from and mounted on bottom horizontal wireway pan	2100H-NPC3
	0.25" x 2" x 12" copper silver plated bus plate with #6-250 kcmil lug (280A capacity)	Insulated from and mounted on top of horizontal wireway pan	2100H-NPS1
		Insulated from and mounted to unit support pan for blank unit space. <b>Blank door not included.</b> Select on page 102.	2100H-NPS2
		Insulated from and mounted on bottom horizontal wireway pan	2100H-NPS3
Bus Stab Isolation Kit	Protective caps—for unused plug-in stab openings. 36 per package.	2100H-N1	
	Manual shutters—for isolation of plug-in stab openings. 12 per package. Available for use on vertical sections, series G through current series.	2100H-SM1	
	Automatic shutters—for isolation of plug-in stab openings. 12 per package. Available for use on vertical sections, series G through current series.	2100H-SA1	
Unit Isolating Barriers	For closing the wire opening between unit and vertical wireway. 6 per package. Series K and later structures.	2100H-N2K	

SC

[1] Cannot be air shipped

[2] A neutral connection plate can be used only in sections with a vertical wireway. Not for use in sections with full width frame mounted units, including all mains.

## Lugs for Field Installation

- Hardware not included.
- One lug per kit.
- For use on:
  - Bulletin 2191 Mains and Feeders
  - Bulletin 2192 400A Disconnect with Optional Lug Pad Assembly\*
  - Bulletin 2192 600-1200A Bolted Pressure Switches
  - Bulletin 2193 with Optional Lug Pad Assembly\*

\* The lugs can only be used if the Bulletin 2192 400A or Bulletin 2193 unit has been ordered with a factory installed lug pad assembly, e.g. option code -82B500

295

Description		Figure #	Catalog Number	Delivery Program	
Lugs for Incoming Line Provisions (2-hole standard NEMA 1-3/4" spacing for 1/2" hardware)  One Lug per Kit	#6-350 kcmil	CU/AL	1	2100H-80350	
	#6-350 kcmil (double barrel lug) For use on 600A incoming line lug compartments only [1]	CU/AL	2	2100H-80350DB	
	#4/0-600 kcmil	CU/AL	1	2100H-80600	
	#4/0-600 kcmil (double barrel lug) For use on 600A incoming line lug compartments only [1]	CU/AL	2	2100H-80600DB	
	350-800 kcmil	CU/AL	1	2100H-80800	
	Crimp Lugs (Panduit Type LCC)	250 kcmil	CU	3	2100H-82250
		350 kcmil	CU	3	2100H-82350
		500 kcmil	CU	3	2100H-82500
		750 kcmil	CU	3	2100H-82750
	Crimp Lugs (Burndy YA-A series)	250 kcmil	CU/AL	3	2100H-83250
		350 kcmil	CU/AL	3	2100H-83350
		500 kcmil	CU/AL	3	2100H-83500
750 kcmil		CU/AL	3	2100H-83750	
Incoming Line Lug Barriers	1.0 space factor			2100H-NLB10	
	1.5 space factor			2100H-NLB15	
	2.0 space factor			2100H-NLB20	

SC

[1] NOT for use on incoming neutral bus. Use single conductor lug for incoming neutral bus applications.

### Lug Dimensions

296

Lug Size	Number of Cables Per Lug	Dimension "A"	Refer to Figure
<b>MECHANICAL TYPE LUGS</b>			
#6-350 kcmil	1	2.13" (54 mm)	1
#4/0-600 kcmil	1	2.31" (59 mm)	1
350-800 kcmil	1	2.25" (57 mm)	1
#6-350 kcmil	2	2.13" (54 mm)	2
#4/0-600 kcmil	2	2.13" (54 mm)	2
<b>CRIMP TYPE LUGS - CU (Panduit Type LCC)</b>			
250 kcmil	1	2.94" (75 mm)	3
350 kcmil		3.38" (86 mm)	
500 kcmil		3.78" (96 mm)	
750 kcmil		4.63" (118 mm)	
<b>CRIMP TYPE LUGS - CU/AL (Burndy YA-A Series)</b>			
250 kcmil	1	2.91" (74 mm)	3
350 kcmil		3.69" (94 mm)	
500 kcmil		4.44" (113 mm)	
750 kcmil		4.94" (125 mm)	

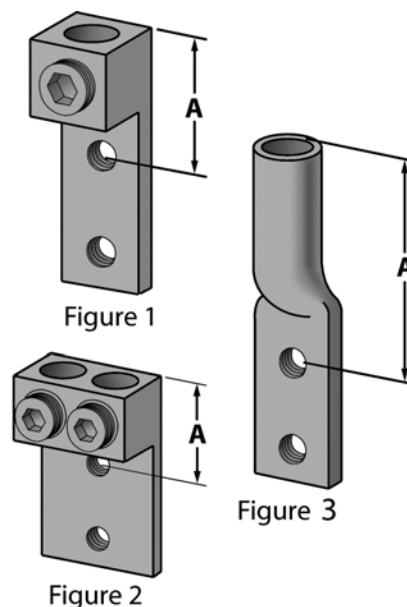

Lugs shown are drilled for 2-hole NEMA 1.75" spacing.

Unit Hardware and Kits for Field Installation

Description			Catalog Number	Delivery Program	
Control Station Housing	Available for use on units series letter H through current series. Housings for series A through G are no longer available.	Blank	2100H-N8	SC	
		1 hole—for one (1) Bulletin 800T pilot device	2100H-N9		
		2 hole—for two (2) Bulletin 800T pilot devices	2100H-N10		
		3 hole—for three (3) Bulletin 800T pilot devices	2100H-N11		
Control Station Mounting Plate	Blank (Bulletin 2103L and 2113 dual only)		2100H-N8D		
		1 hole—for one (1) Bulletin 800T pilot device (Bulletin 2103L and 2113 dual only)	2100H-N9D		
		2 hole—for two (2) Bulletin 800T pilot devices (Bulletin 2103L and 2113 dual only)	2100H-N10D		
		3 hole—for three (3) Bulletin 800T pilot devices (Bulletin 2103L and 2113 dual only)	2100H-N11D		
Door Hardware Kit	Includes two (2) door latch assemblies and two (2) door hinge assemblies	Series H or later	1.0 space factor		2100H-NDH2
			0.5 space factor		2100H-NDH3
Door Hinge Kit <sup>[1]</sup>	Includes two (2) hinges and two (2) hinge pins	Series H or later	0.5 space factor door		2100H-NHP1
		Series E or later	1.0 space factor (or larger) door		2100H-NHP2
Cardholder for Unit Doors	1.125" x 3.625" plastic card holders with blank cards		6 per package		2100H-CH1
Unit Door Nameplates	Engravable acrylic (1.125" x 3.625") (not available in Canada)	White background with black lettering	Blank (6 per package)		2100H-N3AW
			With legend		2100H-N3EAW
		Black background with white lettering	Blank (6 per package)	2100H-N3AB	
			With legend	2100H-N3EAB	
	Engravable phenolic (1.125" x 3.625")	White background with black lettering	Blank (6 per package)	2100H-N3W	
			With legend	2100H-N3EW	
		Red background with white lettering	Blank (6 per package)	2100H-N3R	
			With legend	2100H-N3ER	
Black background with white lettering	Blank (6 per package)	2100H-N3B			
	With legend	2100H-N3EB			
Master Nameplates	Engravable phenolic (2" x 6")	White background with black lettering	With legend	2100H-N3EMW	
		Black background with white lettering		2100H-N3EMB	
Stainless Steel Nameplate Screws	Stainless steel nameplate screws for door or master nameplates (12 per package)			2100H-SSNS1	
Unit Support Pan	Style 1 for units 1.0 space factor or larger, series A through D sections		NEMA Enclosure Type 1, Type 1 with gasket and Type 12	2100H-UAJ1	
	Style 3 for units 1.0 space factor or larger, series E through current series (replaces style 2)		NEMA Enclosure Type 1	2100H-UA1	
			NEMA Enclosure Type 1 with gasket and Type 12	2100H-UJ1	
	Style 3 with interlock bushing, for 0.5 space factor units, series E through current series, with horizontally-toggled unit operating handles (replaces style 2)		NEMA Enclosure Type 1	2100H-USPA1	
NEMA Enclosure Type 1 with gasket and Type 12			2100H-USPJ1		

[1] Use the table below for determining the quantity of hinge and hinge pin kits needed.297

297A

Space Factor	Quantity of Kits Needed
0.5	1
1.0	1
1.5	1
2.0	1
2.5	2
3.0	2
3.5	2
4.0	2
4.5	2
6.0	3

Unit Hardware and Kits for Field Installation, *continued*

Description			Catalog Number	Delivery Program	
Plug-In Unit Retrofit Kit	Permits installation of half (0.5) space factor and NEMA Space Saving starter plug-in units into existing series E through J CENTERLINE 2100 vertical section. Includes hinges, grounding wire and extended unit door latch(es).	0.5 space factor	2100H-R1		
		Greater than 0.5 space factor	2100H-R2		
Unit Insert Extension Kit	Includes 0.5 space factor door and unit extension, twenty (20) pull-apart terminals and hardware to increase usable mounting space of plug-in units	For expanding all 1.0 SF units and Series T and later 1.5 SF units <sup>[1]</sup>	2100H-NXT05B1		
		For expanding Series R and earlier 1.5 SF units and all 2.0 SF through 3.5 SF units <sup>[1]</sup>	2100H-NXT05B2		
Unit Door Grounding Kit	Unit door is grounded by a hinge mounted ground wire. Mounts on bottom hinge of unit door.		2100H-GD1	SC	
Extended Reset Button Kit	Mounts externally to existing door overload reset button. Allows reset of overload relays without use of tools	For small 0.38" reset button screw head. Includes five (5) reset button heads.	2100H-NRB1		
		For large 0.50" reset button screw head. Includes five (5) reset button heads.	2100H-NRB2		
Pull-Apart Terminal Blocks <sup>[2]</sup>	Power terminal block	60A, 3-pole block, accepts #4-#14 AWG wire. Not for use on 0.5 space factor units.	1492-ED103		
	Control terminal block	25A, 5-pole block, accepts #12-#20 AWG wire. Not for use on 0.5 space factor units.	1492-EC85		
Line Terminal Shield	Transparent polycarbonate wraparound line terminal shield permits visual monitoring of conductors and power terminations. Replaces standard line terminal shield. Not available on 0.5 space factor units.	For 30A, 60A, 100A fusible disconnect. 10 per package.	2100H-NLT26		
		For 200A fusible disconnect. Series A-M. 5 per package.	2100H-NLT27		
		For 200A fusible disconnect. Series N and later. 5 per package.	2100H-NLT28		
External Auxiliary Contact Adapter Kits <b>FOR FUSIBLE DISCONNECT:</b> Not for use on 0.5 space factor or dual-mounted units. Auxiliaries are actuated by the unit operating handle.	Permits mounting a maximum of two (2) Bulletin 1495-N8 (normally open) or 1495-N9 (normally closed) auxiliary contacts on the unit operating mechanism, external to the disconnect.	For units with 30A, 60A, 100A, or 200A fusible disconnects	Units Series A-N		None required
		For units with 400A fusible disconnects	Unit Series A-C		1495-N16
			Unit Series D-M	595-N1 <sup>[3]</sup>	
			Unit Series N	None required	
		For units with 600A or 800A fusible disconnects	Unit Series C-L	1495-N13	
Permits mounting a maximum of two (2) Bulletin 2100H-N19 (normally open) or 2100H-N20 (normally closed) auxiliary contacts on the unit operating mechanism, external to the disconnect.	For units with 30A, 60A, 100A, 200A or 400A fusible disconnects	Unit Series Q and later	2100H-N21		
External Auxiliary Contact	One (1) Normally Open	Must be used with external auxiliary adapter kit	Unit Series Q or later	2100H-N19	
	One (1) Normally Closed		2100H-N20		
<b>FOR BOLTED PRESSURE SWITCHES:</b> For 2192F and 2192M 600A, 800A and 1200A units.	Mounts one (1) form C auxiliary contact on the operating mechanism, external to the bolted pressure switch	Unit Series Q and later	2100H-N26A		
	Mounts two (2) form C auxiliary contacts on the operating mechanism, external to the bolted pressure switch		2100H-N26B		

[1] 1.5 space factor Bulletin 2193F with 225 A frame breakers, use kit 2100H-NXT05B2.

[2] Plug-in units have provision for a maximum of four (4) pull-apart terminal blocks (any combination of 3-pole or 5-pole blocks). Not available on 0.5 space factor units.

[3] Kit permits mounting of two (2) Bulletin 595-A (normally open) or 595-B (normally closed) auxiliary contacts only. Not compatible with Bulletin 1495-NB or 1495-NP auxiliary contact kits.

Unit Hardware and Kits for Field Installation, *continued*

Description			Catalog Number	Delivery Program
External Auxiliary Contact Kits	<b>FOR CIRCUIT BREAKERS: For 0.5 space factor units.</b> Auxiliaries are actuated by the unit operating handle only and will not reflect a circuit breaker trip	Mounts one (1) form C auxiliary contact on the operating mechanism, external to the breaker. Allen-Bradley I-Frame or JD-Frame or Cutler-Hammer 150A HMCP, FDB, FD, HFD, FDB-LFD, FDC and 225A JD, HJD and JDC.	Unit Series P and later	2100H-N18A
		Mounts two (2) form C auxiliary contacts on the operating mechanism, external to the breaker. Allen-Bradley I-Frame or JD-Frame or Cutler-Hammer 150A HMCP, FDB, FD, HFD, FDB-LFD, FDC and 225A JD, HJD and JDC.		2100H-N18B
	<b>FOR CIRCUIT BREAKERS:</b> For dual 2103, 2113 and 2193F units	Mounts one (1) form C auxiliary contact on the operating mechanism, external to the breaker. Allen-Bradley I-Frame or Cutler-Hammer FDB, FD, HFD, FDB-LFD and FDC.	Unit Series Q and later	2100H-N25A
		Mounts two (2) form C auxiliary contacts on the operating mechanism, external to the breaker. Allen-Bradley I-Frame or Cutler-Hammer FDB, FD, HFD, FDB-LFD and FDC.		2100H-N25B
External Auxiliary Contact Adapter Kits <b>FOR CIRCUIT BREAKERS:</b> Not for use on 0.5 space factor units. Auxiliaries are actuated by the unit operating handle only and will not reflect a circuit breaker trip.	Permits mounting a maximum of two (2) Bulletin 1495-N8 (normally open) or 1495-N9 (normally closed) auxiliary contacts on the unit operating mechanism, external to the circuit breaker	For units with dual circuit breakers only. Allen-Bradley I-Frame or Cutler-Hammer Series C 150A HMCP, FDB, FD, HFD, FDB-LFD and FDC.	Unit Series K-N	2100H-N16
		For units with single circuit breakers only. Allen-Bradley I, JD, or K Frame or Cutler-Hammer Series C 150A HMCP, FDB, FD, HFD, FDB-LFD, FDC 225/250A JD, HFD, JDC, HMCP 400A HMCP, KD, HKD and KDC.		2100H-N17
		For units with Cutler-Hammer 225A frame (MCP 225A and JB) and 400A frame (MCP 400, LBB, or HLB) circuit breakers	Unit Series C-G	1495-N16
		For units with Cutler-Hammer 600A LC, HLC circuit breakers	Unit Series C-N	1495-N13
		For units with Cutler-Hammer 800A MC, HMC, MDS, ND, HND, or NDC circuit breakers	Unit Series C-N	
		For units with Allen-Bradley Q Frame MCP or Cutler-Hammer 600A L-frame (LD, HLD, or LDC) and 600A HMCP circuit breakers	Unit Series N	
		For units with Cutler-Hammer 1200A NC, HNC, ND, HND, or NDC circuit breakers	Unit Series C-N	
	Permits mounting a maximum of two (2) normally open (2100H-N19) or normally closed (2100H-N20) auxiliary contacts on the unit operating mechanism, external to the circuit breaker	For units with single circuit breakers only. Allen-Bradley I, JD, or K Frame or Cutler-Hammer Series C. 150A HMCP, FDB, FD, HFD, FDB-LFD and FDC. 250A HMCP, JD, HJD and JDC. 400A HMCP, KD, HKD and KDC.	Units Series Q and later	2100H-N22
For units with Allen-Bradley Q Frame MCP or Cutler-Hammer 600A HMCP, LD, HLD, or LDC. 800A MC, HMC, MDS, MDL, HMDL, ND, HND, or NDC. 1200A ND, HND, or NDC circuit breakers.		Unit Series Q and later	2100H-N23	

SC

Unit Hardware and Kits for Field Installation, *continued*

Description		1-Pole 120/240V AC, 10kA rms symmetrical interrupting capacity	2-Pole 120/240V AC, 10kA rms symmetrical interrupting capacity	3-Pole 120/240V AC, 10kA rms symmetrical interrupting capacity	Delivery Program
		Catalog Number	Catalog Number	Catalog Number	
Bolt-on Inverse Time (Thermal Magnetic) Branch Breakers for Lighting Panels (2193LE) <sup>[1]</sup>	15A	2100-B1015	2100-B2015	2100-B3015	SC
	20A	2100-B1020	2100-B2020	2100-B3020	
	30A	2100-B1030	2100-B2030	2100-B3030	
	15A with ground fault	2100-B1015G	—	—	
	20A with ground fault	2100-B1020G	—	—	
	50A	—	2100-B2050	2100-B3050	
	100A	—	2100-B2100	2100-B3100	
	Filler plates (10 per package)	2100-FILLER	—	—	
		1-Pole 277V AC, 14kA rms symmetrical interrupting capacity	2-Pole 480Y/277V AC, 14kA rms symmetrical interrupting capacity	3-Pole 480Y/277V AC, 14kA rms symmetrical interrupting capacity	
Inverse Time (Thermal Magnetic) Branch Breakers for Panel Board Plug-In Unit (2193PP) <sup>[2]</sup>	15A	2100-GHB1015	2100-GHB2015	2100-GHB3015	PE
	20A	2100-GHB1020	2100-GHB2020	2100-GHB3020	
	25A	2100-GHB1025	2100-GHB2025	2100-GHB3025	
	30A	2100-GHB1030	2100-GHB2030	2100-GHB3030	
	35A	2100-GHB1035	2100-GHB2035	2100-GHB3035	
	40A	2100-GHB1040	2100-GHB2040	2100-GHB3040	
	50A	2100-GHB1050	2100-GHB2050	2100-GHB3050	
	60A	2100-GHB1060	2100-GHB2060	2100-GHB3060	
	70A	2100-GHB1070	2100-GHB2070	2100-GHB3070	
	80A	2100-GHB1080	2100-GHB2080	2100-GHB3080	
	90A	2100-GHB1090	2100-GHB2090	2100-GHB3090	
	100A	2100-GHB1100	2100-GHB2100	2100-GHB3100	
	Filler plates (10 per package)	2100-FILLER	—	—	SC

[1] Bolt-on branch breaker frame type for lighting panel boards is BAB.

[2] Bolt-on branch breaker frame type for plug-in panel board unit is GHB.

DeviceNet Hardware and Kits for Field Installation

Description		Catalog Number	Delivery Program	
DeviceNet Scanner Modules	DeviceNet scanner module for Bulletins 2180E, 2182E and 2183E	For Bulletin 1771 I/O chassis 1771-SDN	[1]	
	DeviceNet scanner module for Bulletins 2180J, 2182J and 2183J	For SLC 500 chassis 1747-SDN	[1]	
	DeviceNet scanner module for Bulletins 2180L, 2182L and 2183L	For Bulletin 1756 chassis 1756-DNB	[1]	
MCC DeviceNet Terminating Resistor Kit	Includes the necessary DeviceNet connectors and resistors to terminate the DeviceNet cable system in a motor control center. NOTE: if terminating resistors are not used, the DeviceNet cable system will not operate correctly. This kit is shipped with each DeviceNet motor control center.	2100H-DNTR1	SC	
DeviceNet Terminating Resistors	(2) 120 ohm, 5% terminating a DeviceNet trunk cable. NOTE: if terminating resistors are not used, the DeviceNet cable system will not operate correctly.	1485A-C2	[1]	
Double DeviceNet Connector	Allows two DeviceNet cables to be independently connected to a single DeviceNet port in the MCC vertical wireway.	1485P-P1J5-UU5	[1]	
DeviceNet Connection Cover Kit	For covering unused DeviceNet connectors in the vertical wireway of a DeviceNet MCC. 6 per package.	2100H-DNCC1	SC	
DeviceNet Unit Cable	Cable used for connecting DeviceNet MCC units to the DeviceNet ports in vertical wireway. Includes cable and (1) connector on each end of the cable.	18 in. (45.7 cm)		2100H-DNUC18
		36 in. (91.4 cm)		2100H-DNUC36
		60 in. (152.4 cm)		2100H-DNUC60
Round DeviceNet Cable with Connectors	8A round DeviceNet cable with (1) connector on each end for connecting a laptop computer to a DeviceNet port in an IntelliCENTER or DeviceNet MCC	10 ft. (305 cm)	2100H-ICPC120	
DeviceNet Trunk Line Cable [2]	8A flat DeviceNet cable used for trunk lines	246 ft. (75 m)	1485C-P1E75	[1]
8A Round DeviceNet Cable [2]	8A round DeviceNet cable used for drop lines	164 ft. (50 m)	2100H-DNRC1	SC
	8A round DeviceNet cable uses for extending the trunk line beyond the MCC. Class I, shielded cable	246 ft. (75 m)	1485C-P1BS75	[1]
DeviceNet Field Support Kit	Includes an assortment of DeviceNet-related components that aid in starting up DeviceNet systems, commissioning DeviceNet nodes, testing DeviceNet devices and training on DeviceNet. See publication MCC-TD001x-EN-P, <i>Field Support Kit for CENTERLINE MCCs with IntelliCENTER Technology</i> , for complete information.	2100H-DFSK2	SC	
DeviceNet Backup Power Supply	Provides an alternative source of DC power to supply power to devices such as E3 electronic overload relays in the event of loss of normal network power. For more information refer to publication 2100-TD022x-EN-P	2100-DNBPS		

[1] Contact your local Rockwell Automation Sales Office for ordering information.-

[2] Refer to publication DNET-UM072x-EN-P, *DeviceNet Media Design and Installation Manual*, for application information.

# Appendix

## Approximate Dimensions

All 6.0 space factor units are frame mounted and do not have a vertical wireway.

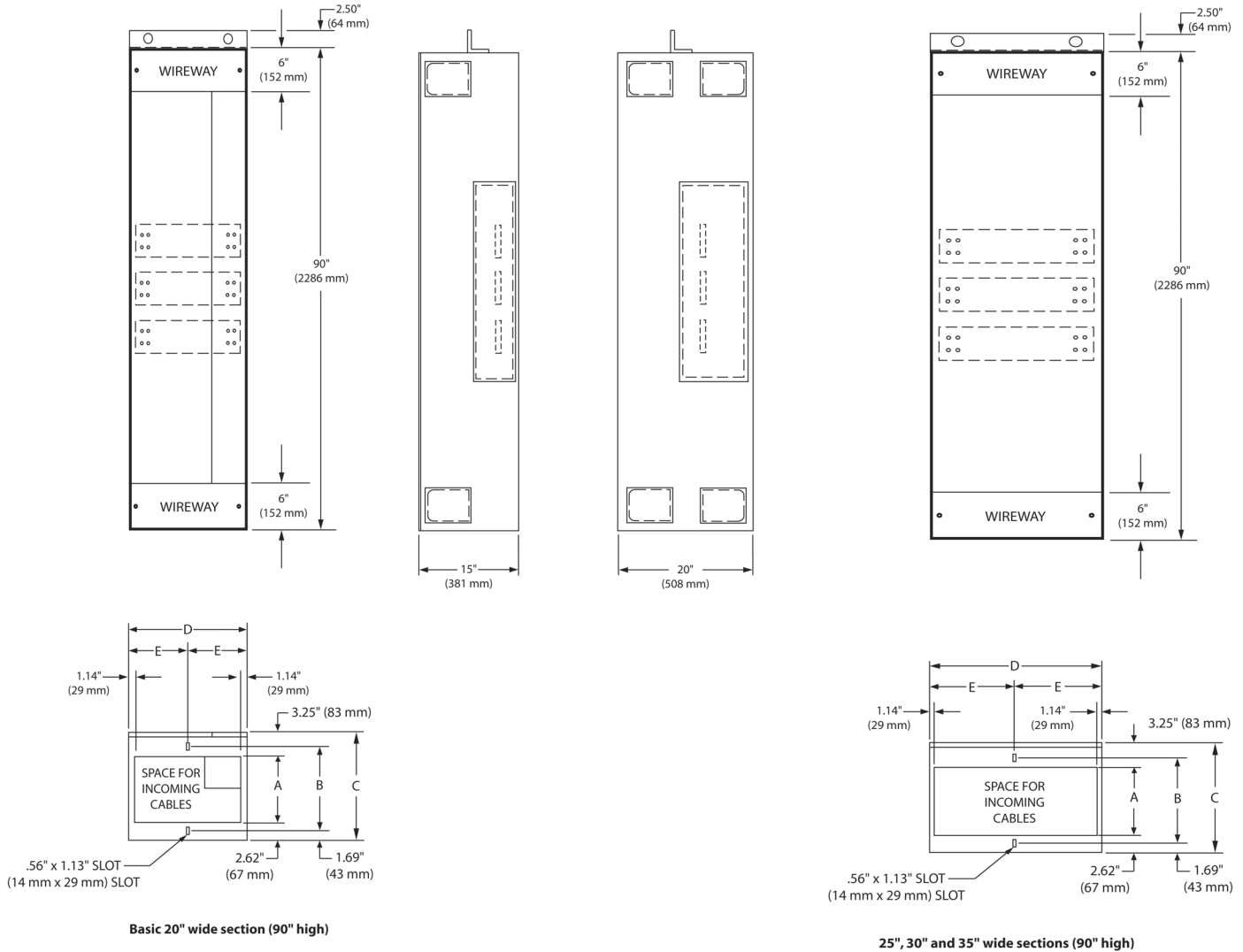

302

Dimension	15" Deep				20" Deep											
	20" Wide		25" Wide		20" Wide		25" Wide		30" Wide		35" Wide					
	inch	(mm)	inch	(mm)	inch	(mm)	inch	(mm)	inch	(mm)	inch	(mm)				
<b>A</b>	9.13	(232)	9.13	(232)	9.13	(232)	9.13	(232)	14.13	(359)	14.13	(359)	14.13	(359)	14.13	(359)
<b>B</b>	11.56	(294)	11.56	(294)	11.56	(294)	11.56	(294)	16.56	(421)	16.56	(421)	16.56	(421)	16.56	(421)
<b>C</b>	15.00	(381)	15.00	(381)	15.00	(381)	15.00	(381)	20.00	(508)	20.00	(508)	20.00	(508)	20.00	(508)
<b>D</b>	20.00	(508)	25.00	(635)	30.00	(762)	35.00	(889)	20.00	(508)	25.00	(635)	30.00	(762)	35.00	(889)
<b>E</b>	10.00	(254)	12.50	(318)	15.00	(381)	17.50	(445)	10.00	(254)	12.50	(318)	15.00	(381)	17.50	(445)

**NOTE:** Optional external mounting channels add 1.5" to height. Refer to page 213 for mounting channels.

25" Section

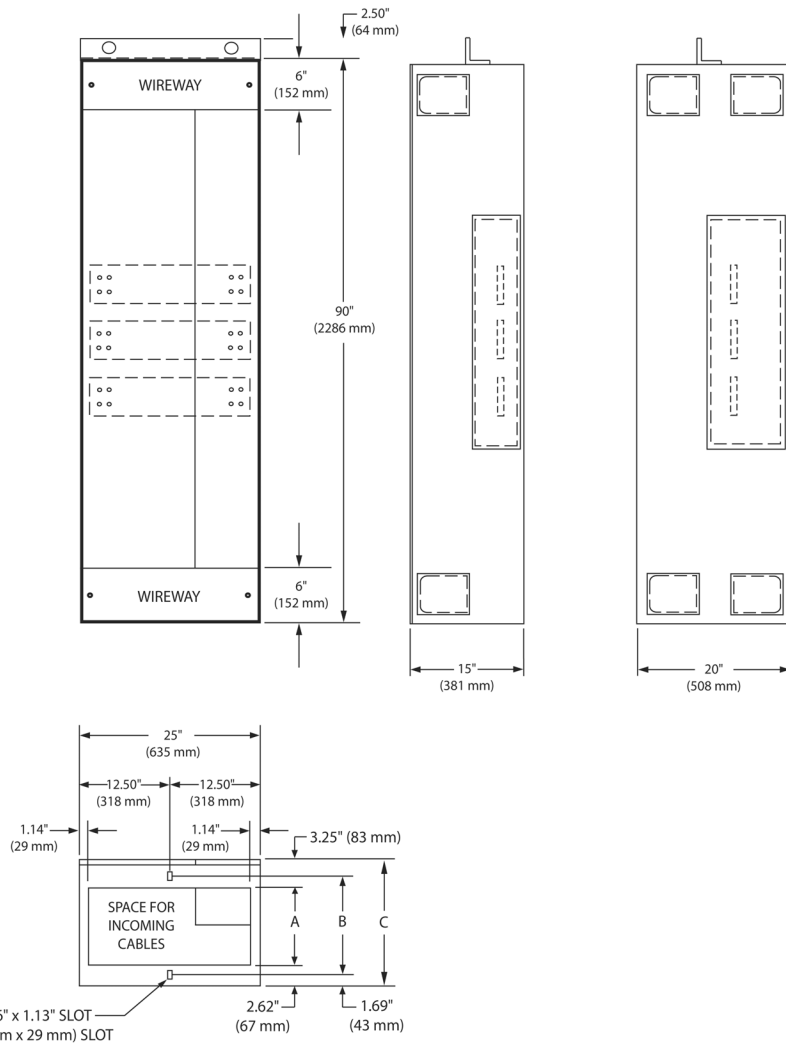

10" Section

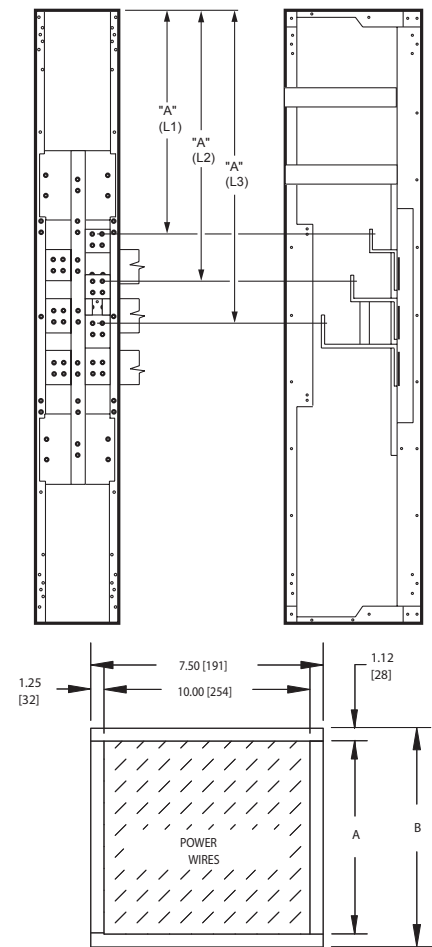

25" Wide Section with 9" Wireway (90" High)

Dimensions	Section Depth			
	15" Deep		20" Deep	
	inch	(mm)	inch	(mm)
A	9.13	(232)	14.13	(359)
B	11.56	(294)	16.56	(421)
C	15.00	(381)	20.00	(508)

NOTE: Optional external mounting channels add 1.5" to height. Refer to page 213 for mounting channels.

10" Incoming Line Section

Dimensions	Section Depth			
	15" Deep		20" Deep	
	inch	(mm)	inch	(mm)
A	12.75	(324)	17.75	(451)
B	14.75	(375)	19.75	(502)

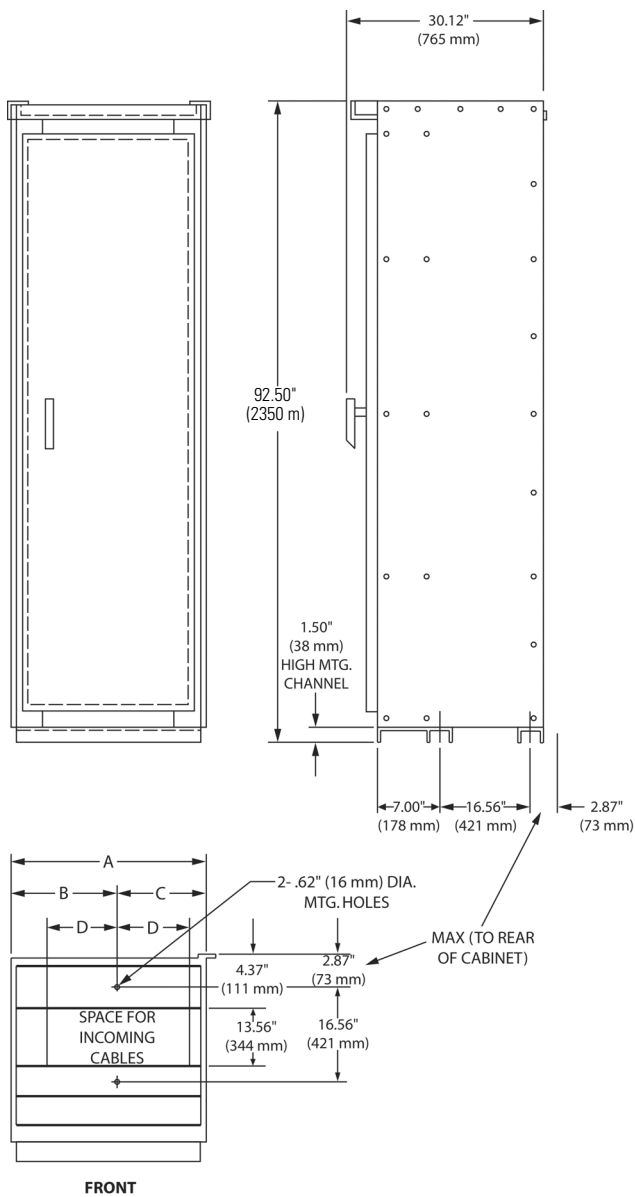

NEMA Type 3R and Type 4 section (90" high)

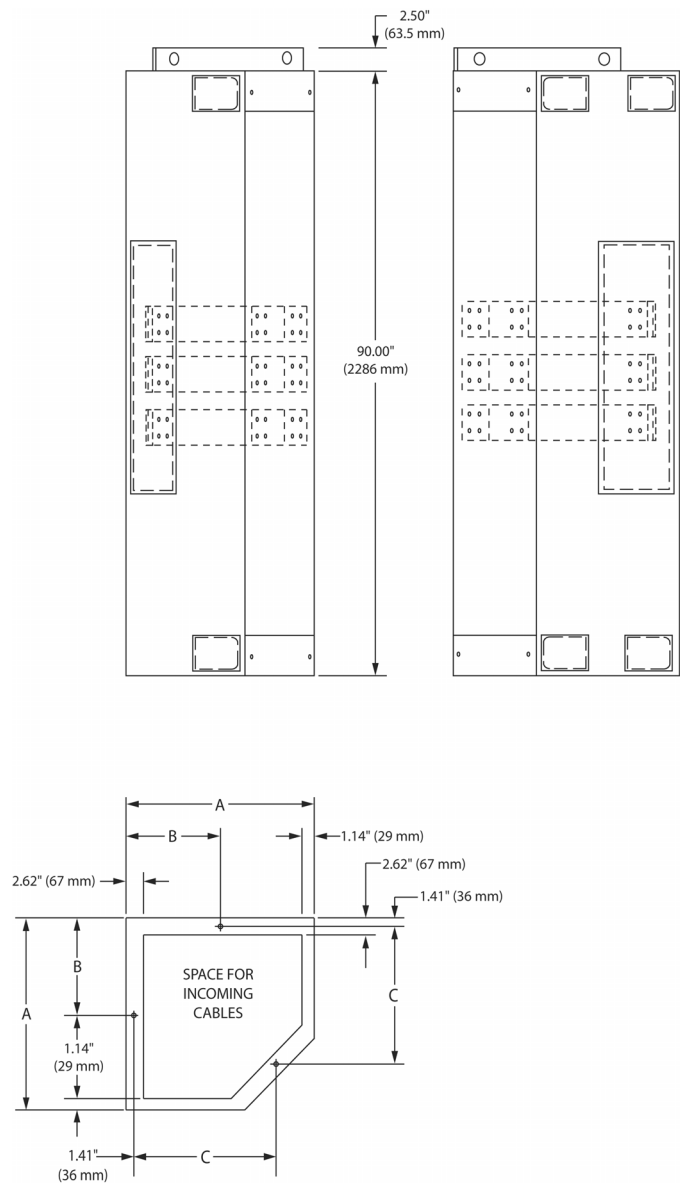

Corner section (90" high)

Floor Plan Dimensions	Interior Section Width <sup>304</sup>					
	20"		25"		30"	
	inch	(mm)	inch	(mm)	inch	(mm)
<b>A</b>	25.00	(635)	30.00	(762)	35.00	(889)
<b>B</b>	13.75	(349)	16.25	(413)	18.75	(476)
<b>C</b>	11.25	(286)	13.75	(349)	16.25	(413)
<b>D</b>	8.87	(225)	11.37	(289)	13.87	(352)

NOTE: Optional non-removal lifting angle add 3.63" to height.

Dimension	Section Depth <sup>305</sup>			
	15" Deep		20" Deep	
	inch	(mm)	inch	(mm)
<b>A</b>	25.13	(638)	30.13	(765)
<b>B</b>	12.63	(321)	15.13	(384)
<b>C</b>	16.81	(427)	21.81	(554)

NOTE: Optional external mounting channels add 1.5" to height. Refer to page 213 for mounting channels.

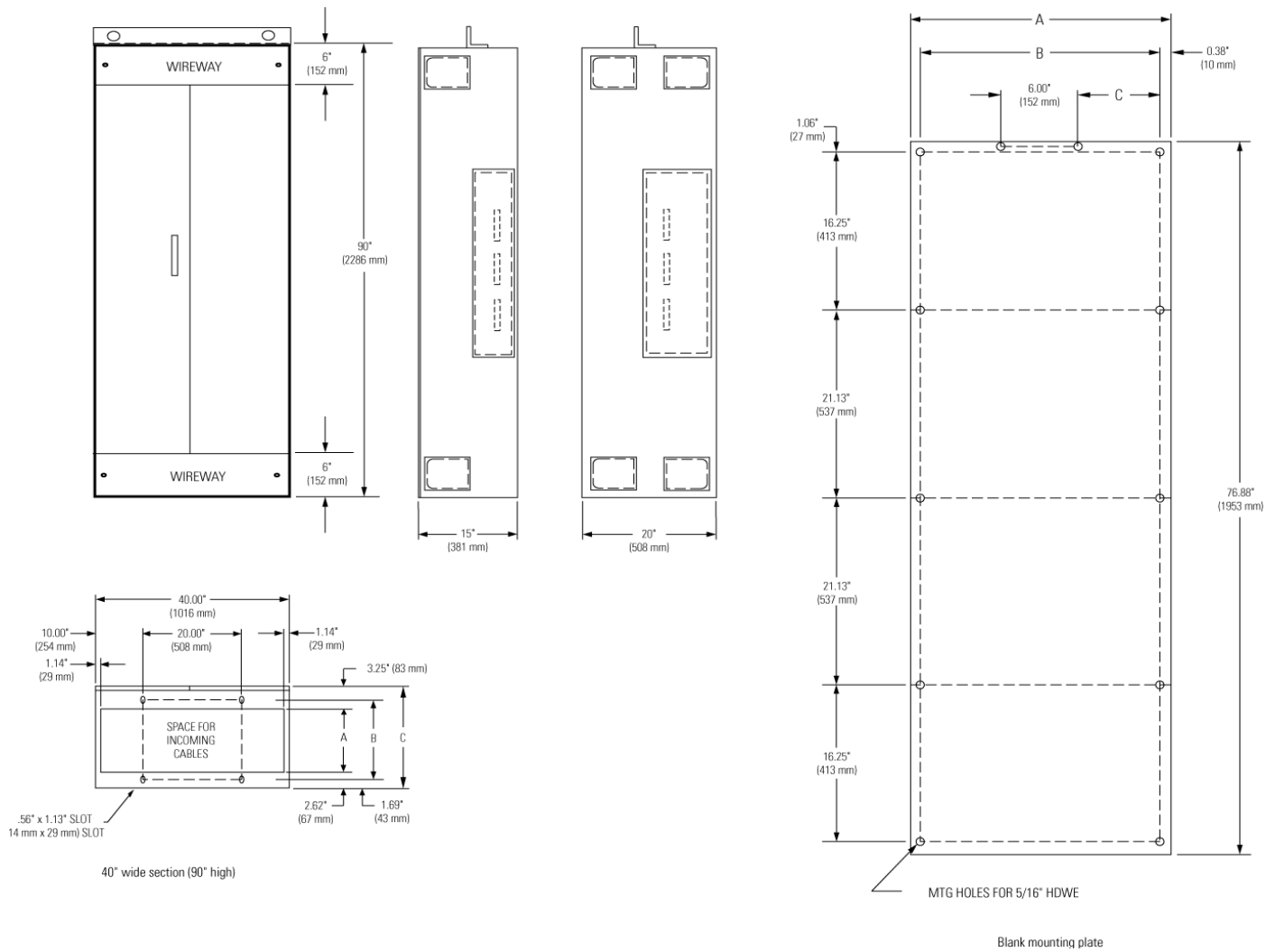

306

Dimension	Section Depth			
	15" Deep		20" Deep	
	inch	(mm)	inch	(mm)
<b>A</b>	9.13	(232)	14.13	(359)
<b>B</b>	11.00	(294)	16.56	(421)
<b>C</b>	15.00	(381)	20.00	(508)

Dimension	Section Width									
	20"		25"		30"		35"		40"	
	inch	(mm)	inch	(mm)	inch	(mm)	inch	(mm)	inch	(mm)
<b>A<sup>[1]</sup></b>	17.25	(438)	22.25	(565)	27.25	(692)	32.25	(819)	37.25	(946)
<b>B</b>	16.50	(419)	21.50	(546)	26.50	(673)	31.50	(800)	36.50	(927)
<b>C</b>	5.25	(133)	7.75	(197)	10.25	(260)	12.75	(324)	15.25	(387)

[1] When horizontal bus or a disconnecting means (switch or circuit breaker) is specified, reduce dimension 'A' by 5."

**NOTE:** Optional external mounting channels add 1.5" to height. Refer to page 213 for mounting channels.

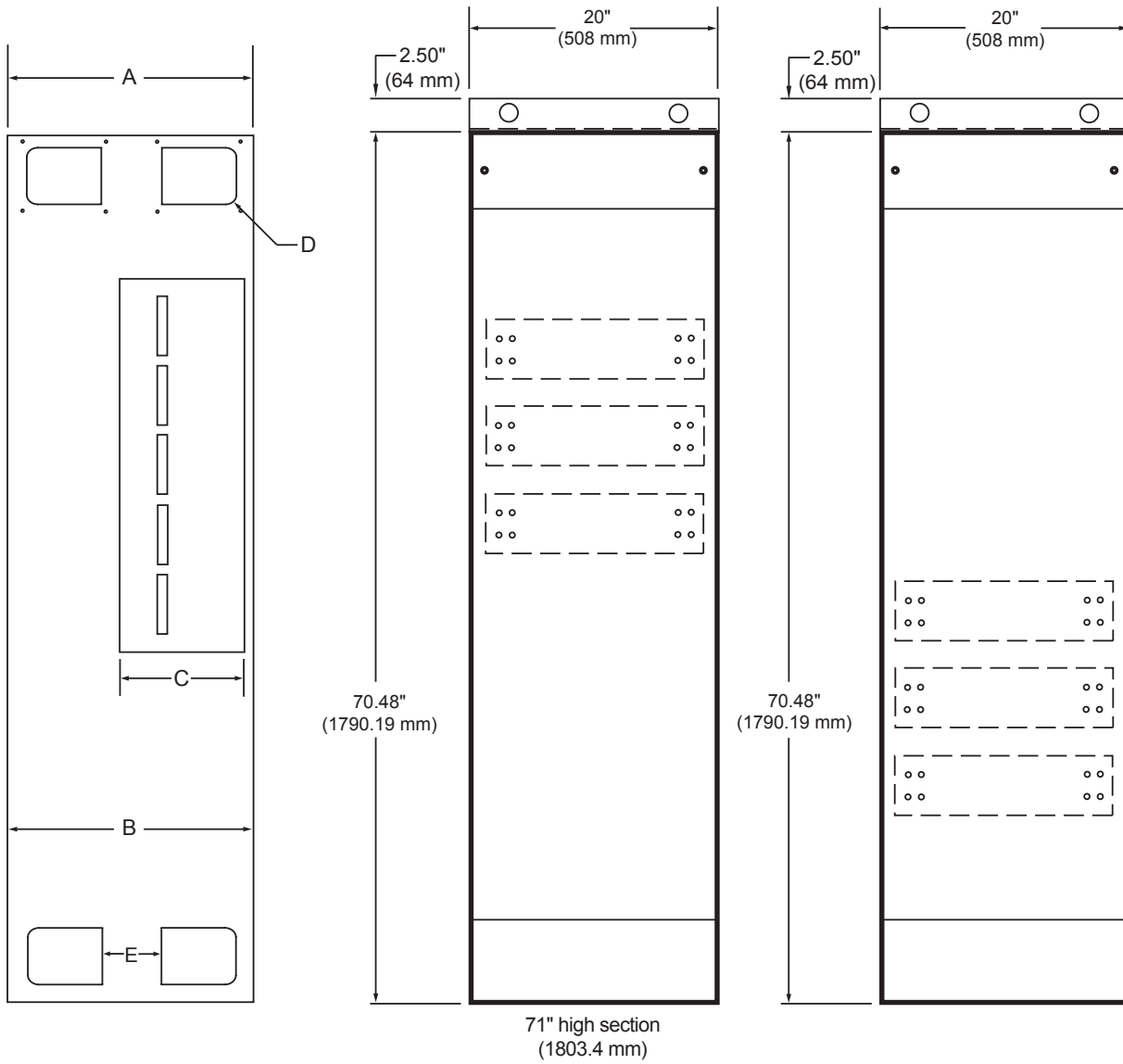

307

Dimensions	Section Depth			
	15" Deep		20" Deep	
	inch	(mm)	inch	(mm)
<b>A</b>	15.00	(380)	20.00	(508)
<b>B</b>	14.75	(374)	19.75	(500)
<b>C</b>	5.12	(130)	10.12	(256)
<b>D</b>	4	(101)	8	(203)
<b>E</b>	—	—	4.40	(112)

**NOTE:** Refer to page 221 for details of cabinet bottom.

## Appendix

### Motor Control Center Construction

308

Major Structural Components	Nominal		Approximate Gauge (AWG)
	inches	mm	
Side Plates	0.075	1.905	14
Reinforcing "C" Channel	0.105	2.667	12
Backplate 20" Wide	0.067	1.70	15
Backplate 25" Wide	0.067	1.70	15
Backplate 25" - 40" Wide	0.105	2.667	12
Bottom Mounting Angle	0.164	4.166	8
Right-Hand Unit Support	0.075	1.905	14
<b>Covers and Panels</b>			
Top Plate (all widths)	0.075	1.905	14
Bottom Plate	0.075	1.905	14
External End Plate	0.075	1.905	14
Horizontal Wireway Cover	0.060	1.524	16
Wireway Baffle	0.075	1.905	14
Top Horizontal Wireway Pan	0.060	1.524	16
<b>Doors</b>			
Unit Door (1.0 - 5.0 Space Factor)	0.075	1.905	14
Unit Door (6.0 Space Factor)	0.105	2.667	12
Vertical Wireway Door	0.060	1.524	16
<b>Other Steel</b>			
Pull Box Parts	0.075	1.905	14
Unit Wrap Around	0.075	1.905	14
Unit Support Pan	0.075	1.905	14

### Approximate Weights of CENTERLINE Motor Control Center Sections

309

MCC Section Dimensions	NEMA 1 or 12	NEMA 3R or 4
	Lbs. (kg) per section <sup>[1]</sup>	Lbs. (kg) per section <sup>[1]</sup>
15"/20" D, 20" W	750 (340)	950 (431)
15"/20" D, 25" W	750 (340)	1000 (454)
15"/20" D, 30" W	800 (363)	1050 (477)
15"/20" D, 35" W	800 (363)	N/A

[1] Weights are based on worst case approximations.

### MCC Finish

310

NEMA Type	Finish
1, 1G, 12	ANSI 49, Medium Light Grey
3R	High Gloss White (outside only)

## Heater Element Selection

### Overload Relay Class Designations

Industry standard NEMA Part ICS 2-222 designates an overload relay by a class number, indicating the maximum time in seconds at which the relay will trip when carrying a current equal to 600 percent of its current rating.

A class 10 overload relay will trip in 10 seconds or less at a current equal to 600 percent of its rating. Applications include hermetic motors, submersible pumps and motors with short locked rotor time capability. A class 20 overload relay will trip in 20 seconds or less at a current equal to 600 percent of its rating. They are often used for applications involving motors driving high inertia loads, where additional accelerating time is needed.

Allen-Bradley standard overload relay protection using type W heater elements provides class 20 operation and is recommended for general applications. For applications regarding class 10 and 30 overload relays, consult your local Rockwell Automation Sales Office.

### Heater Element Selection

The “Full Load Amps” listed in the table are to be used for heater element selection. The rating of the relay in amperes at 40°C is 115% of the full load amps listed for the “Heater Element No.”

Refer to the motor nameplate for the full load current, the service factor and the motor classification by application and temperature rise.

Use this motor nameplate information, the application rules and the full load amps listed in the tables to determine the Heater Element No.

### Motors Rated For Continuous Duty

#### Motors with marked service factor of not less than 1.15 or motors with a marked temperature rise not over 40°C.

- 1.) The same temperature at the controller and motor—Select the heater element number with the listed full load amps nearest the full load value shown on the motor nameplate. This will provide integral horsepower motors with protection between 110 and 120% of the nameplate full load currents.
- 2.) Higher temperature at the controller than at the motor—\*If the full load current value shown on the motor nameplate is between the listed full load amps, select the heater element number with the higher value. This will provide integral horsepower motors with protection between 115 and 125% of the nameplate full load currents.
- 3.) Lower temperature at the controller than at the motor—If the full load current value shown on the motor nameplate is between the listed full load amps, select the heater element number with the lower value. This will provide integral horsepower motors with protection between 105 and 115% of the nameplate full load currents.

#### All Other Motors Rated For Continuous Duty (Includes Motors With Marked Service Factor Of 1.0)

Select the heater element number one rating smaller than determined by the rules in paragraphs 1, 2 and 3. This will provide protection at current levels 10% lower than indicated above.

### Motors Rated For Intermittent Duty

Consult your local Rockwell Automation Sales Office.

\* Rules 2 and 3 apply when the temperature difference does not exceed 10°C (18°F). Consult your local Rockwell Automation Sales Office when the temperature difference is greater.

### Class 20 Curve

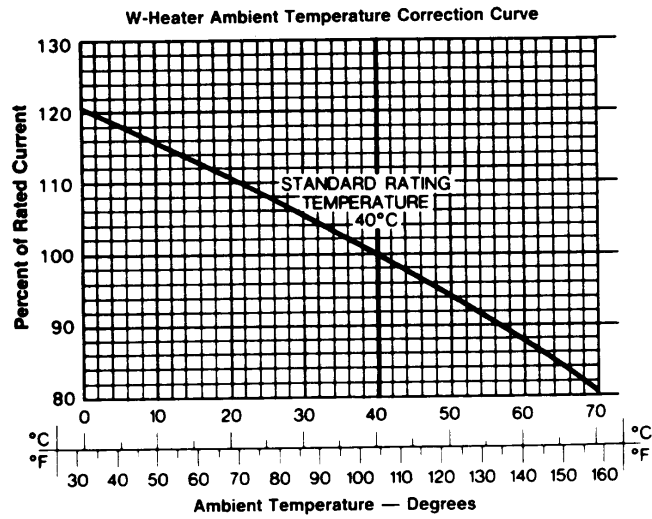
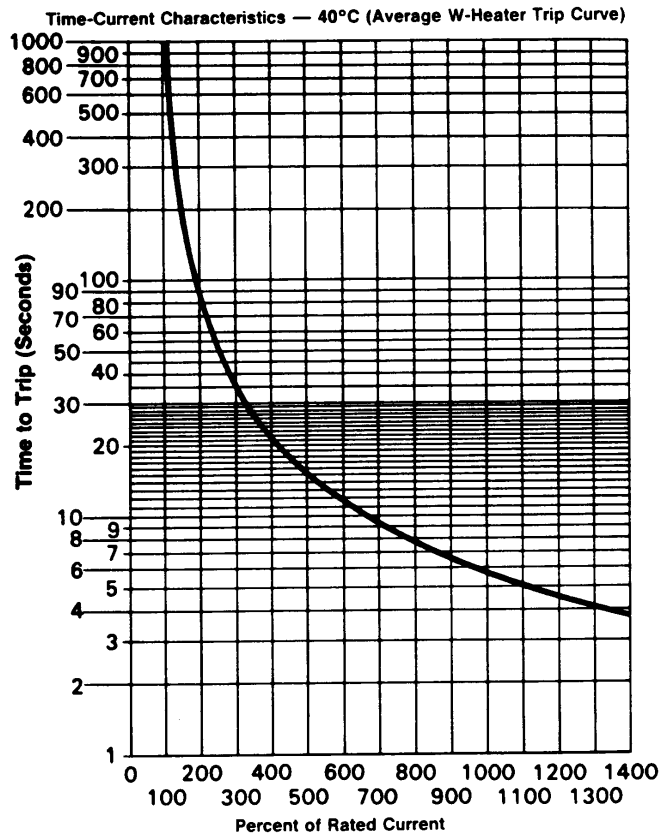

## Heater Element Selection Tables

### Index to Heater Element Selection Tables

311

Device	Bulletin Number	Size	Table Number
Combination Motor Starters	2106/2107	NEMA 1-4	143
		NEMA 5	347
	2112/2113 (0.5 space factor)	NEMA 1	181
		2112/2113 <sup>[1]</sup>	NEMA 1-4
	NEMA 5		347
	NEMA 6		195
	2112/2113	Vacuum contactor starters	195
	2113 <sup>[1]</sup>	NEMA 3, 4	152
	2113 Dual	NEMA 1	141
		NEMA 2	146
	2122/2123	NEMA 1-4	143
		NEMA 5	347
	2126/2127	NEMA 1-2	143

[1] For Bulletin 2113 NEMA size 3 in 1.5 space factor units and NEMA size 4 in 2.0 space factor units, use Table 152.

**Table 141**

312

Heater Element Number	Full Load Amps		Heater Element Number	Full Load Amps	
	Size 1	Size 2		Size 1	Size 2
W10	0.18	—	W38	2.73	—
W11	0.20	—	W39	3.00	—
W12	0.22	—	W40	3.30	—
W13	0.24	—	W41	3.63	—
W14	0.27	—	W42	4.00	—
W15	0.30	—	W43	4.40	—
W16	0.33	—	W44	4.84	—
W17	0.36	—	W45	5.32	—
W18	0.40	—	W46	5.84	—
W19	0.44	—	W47	6.41	—
W20	0.48	—	W48	7.03	—
W21	0.53	—	W49	7.72	—
W22	0.59	—	W50	8.47	—
W23	0.65	—	W51	9.3	—
W24	0.72	—	W52	10.2	—
W25	0.79	—	W53	11.2	—
W26	0.87	—	W54	12.3	—
W27	0.96	—	W55	13.3	—
W28	1.05	—	W56	14.8	—
W29	1.16	—	W57	16.1	—
W30	1.27	—	W58	17.5	—
W31	1.40	—	W59	19.0	—
W32	1.54	—	W60	20.7	—
W33	1.70	—	W61	22.5	—
W34	1.87	—	W62	24.5	—
W35	2.05	—	W63	26.6	—
W36	2.26	—	W64	28.8	—
W37	2.48	—	—	—	—

**Table 143**

313

Heater Element Number	Full Load Amps			
	Size 1	Size 2	Size 3	Size 4
W10	0.19	—	—	—
W11	0.21	—	—	—
W12	0.23	—	—	—
W13	0.25	—	—	—
W14	0.28	—	—	—
W15	0.30	—	—	—
W16	0.33	—	—	—
W17	0.36	—	—	—
W18	0.40	—	—	—
W19	0.44	—	—	—
W20	0.49	—	—	—
W21	0.53	—	—	—
W22	0.58	—	—	—

Heater Element Number	Full Load Amps			
	Size 1	Size 2	Size 3	Size 4
W23	0.64	—	—	—
W24	0.70	—	—	—
W25	0.77	—	—	—
W26	0.85	—	—	—
W27	0.93	—	—	—
W28	1.02	—	—	—
W29	1.12	—	—	—
W30	1.23	—	—	—
W31	1.35	—	—	—
W32	1.48	—	—	—
W33	1.62	—	—	—
W34	1.79	—	—	—
W35	1.97	—	—	—
W36	2.18	—	—	—
W37	2.40	—	—	—
W38	2.65	—	—	—
W39	2.92	—	—	—
W40	3.23	—	—	—
W41	3.56	—	—	—
W42	3.93	—	—	—
W43	4.30	—	—	—
W44	4.71	—	—	—
W45	5.16	—	—	—
W46	5.66	—	—	—
W47	6.28	—	—	—
W48	6.94	—	—	—
W49	7.71	—	—	—
W50	8.45	8.56	—	—
W51	9.29	9.4	—	—
W52	10.3	10.4	—	—
W53	11.4	11.5	—	—
W54	12.5	12.6	—	—
W55	13.7	13.8	—	—
W56	15.0	15.1	—	—
W57	16.3	16.4	—	—
W58	17.7	17.9	—	—
W59	19.3	19.5	—	—
W60	20.9	21.2	—	—
W61	22.7	23.0	25.4	—
W62	24.7	25.1	27.8	—
W63	26.9	27.3	30.5	—
W64	29.2	29.7	33.5	35.0
W65	—	31.5	37.0	38.5
W66	—	34.5	40.5	42.0
W67	—	37.5	44.5	46.0
W68	—	41.0	48.5	51.0
W69	—	44.0	53.0	56.0
W70	—	47.0	59.0	61.0
W71	—	—	64.0	66.0
W72	—	—	69.0	71.0
W73	—	—	73.0	76.0
W74	—	—	77.0	82.0
W75	—	—	81.0	88.0
W76	—	—	85.0	94.0
W77	—	—	90.0	100.0
W78	—	—	—	106.0
W79	—	—	—	113.0
W80	—	—	—	120.0
W81	—	—	—	128.0
W82	—	—	—	135.0

Appendix

Table 146

314

Heater Element Number	Full Load Amps	Heater Element Number	Full Load Amps
	Size 2		Size 2
W45	5.53	W58	17.3
W46	6.04	W59	18.9
W47	6.60	W60	20.6
W48	7.21	W61	22.5
W49	7.87	W62	24.6
W50	8.60	W63	26.8
W51	9.39	W64	29.4
W52	10.3	W65	32.0
W53	11.2	W66	34.5
W54	12.2	W67	37.5
W55	13.3	W68	41.0
W56	14.6	W69	44.5
W57	15.8	—	—

Table 152

315

Heater Element Number	Full Load Amps		
	Size 2	Size 3	Size 4
W45	—	—	—
W46	—	—	—
W47	—	—	—
W48	—	—	—
W49	—	—	—
W50	8.56	—	—
W51	9.4	—	—
W52	10.4	—	—
W53	11.5	—	—
W54	12.6	—	—
W55	13.8	—	—
W56	15.1	—	—
W57	16.4	—	—
W58	17.7	—	—
W59	19.1	—	—
W60	21.1	—	—
W61	23.2	25.1	—
W62	25.7	27.5	—
W63	28.5	30.5	33.0
W64	30.5	33.5	36.0
W65	33.0	36.5	39.5
W66	35.5	40.0	43.0
W67	38.5	44.0	47.0
W68	41.5	48.0	51.0
W69	45.0	53.0	56.0
W70	—	58.0	61.0
W71	—	62.0	66.0
W72	—	67.0	72.0
W73	—	72.0	77.0
W74	—	77.0	83.0
W75	—	82.0	89.0
W76	—	88.0	95.0
W77	—	94.0	102.0
W78	—	—	108.0
W79	—	—	116.0
W80	—	—	123.0
W81	—	—	130.0
W82	—	—	137.0

Table 181

316

Heater Element Number	Full Load Amps
	2112/2113 Size 1 0.5 Space Factor
W23	0.67
W24	0.74
W25	0.84
W26	0.90
W27	1.00
W28	1.10
W29	1.22
W30	1.31
W31	1.43
W32	1.55
W33	1.66
W34	1.80
W35	1.97
W36	2.12
W37	2.33
W38	2.59
W39	2.84
W40	3.15
W41	3.46
W42	3.84
W43	4.27
W44	4.73
W45	5.36
W46	5.82
W47	6.33
W48	6.97
W49	7.63
W50	8.49
W51	9.24
W52	10.1
W53	11.1
W54	12.2
W55	13.6
W56	14.6
W57	15.7
W58	17.2
W59	18.9
W60	20.5
W61	22.2
W62	24.2
W66	—
W67	—
W68	—
W69	—
W70	—
W71	—
W72	—
W73	—
W74	—
W75	—
W76	—
W77	—
W78	—
W79	—
W80	—
W81	—
W82	—
W83	—
W84	—
W85	—

Table 195

317

Heater Element Number	Full Load Amps
	2112/2113 Size 6
W26	115
W27	125
W28	135
W29	147
W30	165
W31	179
W32	196
W33	216
W34	232
W35	260
W36	287
W37	315
W38	350
W39	385
W40	420
W41	465
W42	515

317 A

Heater Element Number	Full Load Amps			
	200A	400A Plug-in Unit with 300:5 CT Ratio <sup>[1]</sup>	400A Frame Mounted Unit with 400:5 CT Ratio <sup>[1]</sup>	600A
W31	59 <sup>[2]</sup>	—	—	—
W32	65 <sup>[2]</sup>	—	—	—
W33	70	—	—	—
W34	75	—	150	—
W35	81	—	160	—
W36	89	—	175	287
W37	98	150	195	315
W38	110	160	215	350
W39	120	175	235	385
W40	132	195	260	420
W41	143	215	293	465
W42	155	235	320	—
W43	170	250	350	—
W44	193	293	380	—

[1] 400A Vacuum Contactors Starters use 300:5 CT Ratio except 125HP@208V, 125-150HP@240V, 250HP@380-415V, 250-300HP@480V, and 350-400HP@600V use 400:5 CT Ratio.

[2] Exceeds 20 seconds at six times rating, providing Class 30 protection.

Table 347

318

Heater Element Number	Full Load Amps
	Size 5
W29	77
W30	83
W31	90
W32	98
W33	107
W34	116
W35	126
W36	138
W37	150
W38	164
W39	178
W40	194
W41	212
W42	232
W43	254
W44	270
W45	—

## Appendix

### Full Load Currents

The full load currents listed below are average values for horsepower rated motors of several manufacturers at the more common rated voltages and speeds. These average values, along with the similar values listed in the NEC/UL/cUL, should be used only as a guide for selecting suitable components for the motor branch circuit. The rated full load current, shown on the motor nameplate, may vary considerably from the listed value, depending on the specific motor design.

**IMPORTANT:** The motor nameplate full load current always should be used in determining the rating of the devices used for motor running overcurrent protection.

#### Full Load Current of 3 Phase, 60 Hertz AC Induction Motors

319

HP	RPM	Full Load Current			
		208V	240V	480V	600V
0.25	3600	1.20	1.04	0.52	0.42
	1800	1.39	1.20	0.60	0.48
	1200	1.62	1.40	0.70	0.56
0.33	3600	1.48	1.28	0.64	0.51
	1800	1.69	1.46	0.73	0.58
	1200	1.89	1.64	0.82	0.66
0.50	3600	2.08	1.80	0.90	0.72
	1800	2.54	2.20	1.10	0.88
	1200	2.89	2.50	1.25	1.00
0.75	3600	2.89	2.50	1.25	1.00
	1800	3.47	3.00	1.50	1.20
	1200	3.81	3.30	1.65	1.32
1	3600	3.51	3.04	1.52	1.22
	1800	4.25	3.68	1.84	1.47
	1200	4.60	3.98	1.99	1.59
1.5	3600	5.04	4.36	2.18	1.74
	1800	5.80	5.02	2.51	2.01
	1200	6.49	5.62	2.81	2.25
2	3600	6.51	5.64	2.82	2.26
	1800	7.18	6.22	3.11	2.49
	1200	8.20	7.10	3.55	2.84
3	3600	9.24	8.00	4.00	3.20
	1800	10.4	9.04	4.52	3.62
	1200	11.6	10.1	5.04	4.03
5	3600	15.7	13.6	6.80	5.44
	1800	15.9	13.8	6.88	5.50
	1200	18.6	16.1	8.07	6.46
7.5	3600	22.1	19.1	9.57	7.66
	1800	25.0	21.7	10.8	8.66
	1200	26.6	23.1	11.5	9.22
10	3600	29.7	25.7	12.9	10.3
	1800	31.5	27.3	13.7	10.9
	1200	32.9	28.4	14.2	11.4
15	3600	43.0	37.2	18.6	14.9
	1800	46.7	40.4	20.2	16.2
	1200	49.1	42.5	21.3	17.0
20	3600	59.2	51.3	25.6	20.5
	1800	59.6	51.6	25.8	20.6
	1200	61.7	53.4	26.7	21.4
25	3600	70.9	61.4	30.7	24.6
	1800	74.7	64.7	32.3	25.9
	1200	76.0	65.8	32.9	26.3
30	3600	85.7	74.2	37.1	29.7
	1800	88.2	76.4	38.2	30.5
	1200	91.6	79.3	39.7	31.7

HP	RPM	Full Load Current			
		208V	240V	480V	600V
40	3600	111	96.0	48.0	38.4
	1800	117	102	50.8	40.6
	1200	119	103	51.7	41.4
50	3600	141	122	61.2	49.0
	1800	144	125	62.3	49.8
	1200	147	127	63.4	50.7
60	3600	165	143	71.6	57.3
	1800	172	149	74.3	59.4
	1200	173	150	74.9	59.9
75	3600	204	177	88.5	70.8
	1800	211	183	91.4	73.1
	1200	215	186	93.1	74.5
100	3600	267	231	116	92.6
	1800	276	239	119	95.5
	1200	281	243	122	97.2
125	3600	333	288	144	115
	1800	340	294	147	118
	1200	347	300	150	120
150	3600	397	344	172	138
	1800	404	350	175	140
	1200	414	358	179	143
200	3600	524	454	227	182
	1800	531	460	230	184
	1200	538	466	233	186
250	3600	642	556	278	222
	1800	658	570	285	228
	1200	682	590	295	236
300	3600	774	670	335	268
	1800	790	684	342	274
	1200	804	696	348	278
350	3600	—	748	374	299
	1800	—	762	381	305
	1200	—	774	387	310
400	3600	—	874	437	350
	1800	—	892	446	357
	1200	—	902	451	361
450	3600	—	972	486	389
	1800	—	992	496	397
	1200	—	1004	502	402
500	3600	—	1074	537	430
	1800	—	1096	548	438
	1200	—	1108	554	443

## Full Load Currents

The full load currents listed below are average values for kW rated motors of several manufacturers at the more common rated voltages and speeds. These average values should be used only as a guide for selecting suitable components for the motor branch circuit. The rated full load current, shown on the motor nameplate, may vary considerably from the listed value, depending on the specific motor design.

**IMPORTANT:** The motor nameplate full load current always should be used in determining the rating of the devices used for motor running overcurrent protection.

### Full Load Currents of 3 Phase, 50 Hertz AC Induction Motors

320

kW	Full Load Current (Amperes) Average Values for 4-Pole (1500rpm) Motors				
	220V	230V <sup>[1]</sup>	380V	400V <sup>[1]</sup>	415V
0.25	1.40	1.34	0.88	0.83	0.80
0.37	2.10	2.00	1.20	1.18	1.16
0.55	2.75	2.60	1.50	1.47	1.45
0.75	3.50	3.30	2.10	2.00	1.90
1.1	4.40	4.20	2.60	2.50	2.40
1.5	6.00	5.70	3.50	3.30	3.20
2.2	8.70	8.30	5.00	4.80	4.60
3.7	14	13.4	8.20	7.80	7.50
5.5	20	19.1	11.5	10.9	10.5
7.5	27	25.8	15.5	14.8	14.2
11	39	37.3	22	21.1	20.5
15	52	50	30	29	28
18.5	64	61	37	36	35
22	75	72	44	42	40
30	103	99	60	57	55
37	126	121	72.5	69	66
45	147	141	85	82	80
55	182	174	105	100	96
75	239	229	138	136	135
90	295	282	170	167	165
110	356	341	205	202	200
132	425	407	245	236	230
150	484	463	280	269	260
160	520	497	300	286	275
185	580	555	340	324	312
200	640	612	370	353	340
220	710	679	408	395	385
250	—	—	475	461	450

[1] These values are calculated.

## Inverse Time Thermal Magnetic or Electronic Circuit Breaker Interrupting Capacity Ratings

321

Circuit Breaker Frame	Circuit Breaker Suffix	Breaker Trip Type	Interrupting Capacity Ratings (rms Symmetrical Amperes)		
			208V 230V 240V	380V– 415V 480V	600V
I3C (150A)	CB	Inverse Time (Thermal Magnetic)	65kA	35kA	18kA
I6C (150A)	CM	Inverse Time (Thermal Magnetic)	100kA	65kA	25kA
I0C (150A)	CX	Inverse Time (Thermal Magnetic)	100kA	100kA	35kA
I3C-CL (150A)	CD	Inverse Time (Thermal Magnetic)	100kA	100kA	100kA
JD3D (250A)	CT	Inverse Time (Thermal Magnetic)	65kA	35kA	18kA
JD6D (250A)	CM	Inverse Time (Thermal Magnetic)	100kA	65kA	25kA
JD0D (250A)	CX	Inverse Time (Thermal Magnetic)	100kA	100kA	35kA
K3D (400A)	CT	Inverse Time (Thermal Magnetic)	65kA	35kA	25kA
K6D (400A)	CM	Inverse Time (Thermal Magnetic)	100kA	65kA	35kA
K0D (400A)	CX	Inverse Time (Thermal Magnetic)	100kA	100kA	65kA
LD, LDG (600A)	CT, CTG	Inverse Time (Thermal Magnetic)	65kA	35kA	25kA
HLD, HLDG (600A)	CM, CMG	Inverse Time (Electronic)	100kA	65kA	35kA
LDC, LDCG (600A)	CX, CXG	Inverse Time (Electronic)	100kA	100kA	50kA
MDL, MDLG (800A)	CT, CTG	Inverse Time (Electronic)	65kA	50kA	25kA
HMDL, HMDLG (800A)	CM, CMG	Inverse Time (Electronic)	100kA	65kA	35kA
NDC, NDCG (800A)	CX, CXG	Inverse Time (Electronic)	100kA	100kA	65kA
ND, NDG (1200A)	CT, CTG	Inverse Time (Electronic)	65kA	50kA	25kA
HND, HNDG (1200A)	CM, CMG	Inverse Time (Electronic)	100kA	65kA	35kA
NDC, NDCG (1200A)	CX, CXG	Inverse Time (Electronic)	100kA	100kA	65kA
RD, RDG (2000A)	CM, CMG	Inverse Time (Electronic)	100kA	65kA	50kA

## 3-Pole Inverse Time Circuit Breaker Characteristics for Bulletin 2193F and 2193M Units

322

Rating (Amperes)	Circuit Breaker Frame	Thermal Magnetic Trip Units		Electronic Trip Units (with interchangeable rating plugs) <sup>[1]</sup>						
				Digitrip RMS 310 <sup>[2]</sup>				Digitrip OPTIM 550		
		Inter-changeable	Non-inter-changeable	LS	LSI	LSG	LSIG	LSI	LSIG	LSIA
150	I	—	STD	—	—	—	—	—	—	—
225	JD	STD	[3]	—	—	—	—	—	—	—
400	K	STD	[3]	[3]	[3]	[3]	[3]	[3]	[3]	[3]
600 <sup>[4]</sup>	L	[3]	—	STD	[3]	STD	[3]	[3]	[3]	[3]
800 <sup>[4]</sup>	M,N	[3]	[3]	STD	[3]	STD	[3]	—	—	—
1200 <sup>[4]</sup>	N	—	—	STD	[3]	STD	[3]	[3]	[3]	[3]
2000 <sup>[4]</sup>	R	—	—	STD		STD		—	—	—

[1] Definitions are as follows:

- **LS:** standard trip unit that includes adjustable short time current pickup settings that encompass an I<sup>2</sup>t ramp function.
- **LSI:** optional trip unit that provides additional flat response short time delay adjustments with an instantaneous setting.
- **LSG:** standard LS unit **with ground fault** protection and adjustable pickup current.
- **LSIG:** optional LSI unit **with ground fault** protection and adjustable pickup current and time delay.
- **LSIA:** optional LSI unit **with ground fault alarm** and adjustable pickup current and time delay.

[2] The Digitrip RMS 310 electronic trip unit provides true RMS sensing, permitting increased accuracy. True RMS sensing is not susceptible to nuisance tripping when wave forms containing high harmonic currents are present.

[3] Contact your local Rockwell Automation Sales Office for availability.

[4] Sealed to be suitable for reverse-fed applications. Trip units are not interchangeable. Rating plugs are interchangeable. Trip units are provided with test points for functional field testing with a portable electronic test set. These trip units incorporate a powered thermal memory that recalls near trip conditions and automatically imposes a shorter time delay, thereby preventing system damage from cumulative overheating. These units also incorporate an unpowered thermal memory feature that remembers a trip has occurred and will protect against repeated overload conditions if the CB is re-closed before a sufficient cool down period has elapsed.

## UL/cUL/CSA Short Circuit Withstand Ratings for Combination Fusible Disconnect Units

323

Fuse Class	Device/Bulletin	Size/Rating	Short Circuit Withstand Ratings (Amperes rms Symmetrical)
			UL/cUL/CSA (except where noted) 600V or less
CC	2102L	30A	100kA
	2106, 2112, 2122, 2126	#1	100kA
	2106, 2112 Space Saving NEMA	#1	100kA
H	2102L	30A-100A	5kA
	2102L	200A-300A	10kA
	2106, 2112, 2122, 2126	#1-3	5kA
	2106, 2112, 2122	#4-5	10kA
	2112	#6	10kA
	2112 Vacuum Contactor Starters	200A, 400A, 600A	10kA
	2196		10kA
J, R	2102L	30A-100A	100kA
	2102L	200A- 300A	100kA
	2106, 2112, 2122, 2126	#1-3	100kA
	2106, 2112, 2122	#4-5	100kA
	2106, 2112 Space Saving NEMA	#1	100kA
	2112	#6	100kA
	2112 Vacuum Contactor Starters	200A, 400A, 600A	100kA
2196		100kA	
HRCII-C	2106, 2112, 2122, 2126	#1-3	100kA <sup>[1]</sup>
	2106, 2112, 2122	#4-5	100kA <sup>[1]</sup>
	2106, 2112 Space Saving NEMA	#1	100kA <sup>[1]</sup>
	2112	#6	100kA <sup>[1]</sup>
	2112 Vacuum Contactor Starters	200A, 400A, 600A	100kA
L	2112	#6	100kA

[1] NOT UL listed.

**UL/cUL/CSA Short Circuit Withstand Ratings for Combination Circuit Breaker Units**

Circuit Breaker Frame	Device/Bulletin	Size/Rating	Short Circuit Withstand Ratings (Amperes rms Symmetrical)		
			UL/cUL/CSA (except where noted)		
			208V through 240V	380V through 480V	600V
MCP	2107, 2113, 2123, 2127 <sup>[1]</sup>	#1-3	—	—	25kA
	2107, 2113, 2123, 2127	#1-4	100kA	100kA	50kA
	2107, 2113 Space Saving NEMA	#1-2	—	65kA <sup>[2]</sup>	35kA
	2107, 2113 Space Saving NEMA	#3	—	65kA <sup>[2]</sup>	42kA
	2113 Space Saving NEMA	#4	—	50kA <sup>[2]</sup>	30kA
	2107, 2113, 2123	#5	100kA	100kA	42kA
	2113	#6	100kA	65kA	35kA
MCP w/ ELC	2107, 2113, 2123, 2127	#1-4	100kA	100kA	100kA
I3C	2107, 2113, 2123, 2127	#1-3	65kA	35kA	18kA
	2107, 2113 Space Saving NEMA	#1-2	—	35kA <sup>[2]</sup>	18kA
	2107, 2113 Space Saving NEMA	#3	—	35kA <sup>[2]</sup>	18kA
	2103L, 2197	30A-100A/ 15A-150A	65kA	35kA	18kA
I3C-CL	2107, 2113, 2123, 2127	#1-3	100kA	100kA	100kA
	2103L, 2197	30A-100A/ 15A-150A	100kA	100kA	100kA
I6C	2107, 2113, 2123, 2127	#1-3	100kA	100kA	25kA
	2107, 2113 Space Saving NEMA	#1-2	—	65kA <sup>[2]</sup>	35kA
	2107, 2113 Space Saving NEMA	#3	—	65kA <sup>[2]</sup>	42kA
	2103L, 2197	30A-100A/ 15A-150A	100kA	65kA	25kA
JD3D	2107, 2113, 2123	#4-5	65kA	35kA	18kA
	2113 Space Saving NEMA	#4	—	50kA <sup>[2]</sup>	30kA
	2113 Vacuum Contactor Starters	200A, 400A	65kA	35kA	18kA
	2103L, 2197	200A	65kA	35kA	18kA
JD6D	2107, 2113, 2123	#4, #5	100kA	100kA	42kA
	2113 Space Saving NEMA	#4	—	50kA <sup>[2]</sup>	30kA
	2113 Vacuum Contactor Starters	200A, 400A	100kA	65kA	25kA
	2103L, 2197	200A	100kA	65kA	25kA
K3D	2107, 2113, 2123	#5	65kA	35kA	—
	2113 Vacuum Contactor Starters	400A	65kA	35kA	—
	2103L	300A	65kA	35kA	25kA
K6D	2107, 2113, 2123	#5	100kA	100kA	—
	2113 Vacuum Contactor Starters	400A	100kA	65kA	—
	2103L	300A	100kA	65kA	35kA
LD	2113	#6	65kA	35kA	25kA
	2113 Vacuum Contactor Starters	400A, 600A	65kA	35kA	25kA
HLD	2113	#6	100kA	65kA	35kA
	2113 Vacuum Contactor Starters	400A, 600A	100kA	65kA	35kA
MDL	2113	#6	65kA <sup>[3]</sup>	50kA <sup>[4]</sup>	—
HMDL	2113	#6	100kA <sup>[3]</sup>	65kA <sup>[4]</sup>	—

[1] Circuit breaker suffix CZ.  
 [2] 480V Only.  
 [3] 200HP @240V only.  
 [4] 400HP @480V only.

## UL/cUL/CSA Short Circuit Withstand Ratings for Combination Soft Starter Units (SMCs)

### Combination Fusible Disconnect Soft Starter Units for Bulletin 2154H and 2154J

325

Bulletin Number	SMC Device Rating	Fuse Class	Short Circuit Withstand Ratings (Amperes rms Symmetrical)		
			240V	480V	600V
2154H	3A through 85A	J	100 kA	100 kA	100 kA
	108A and 135A		65kA	65kA	65kA
2154J	5A through 85A		100 kA	100 kA	100 kA
	108A and 135A		65kA	65kA	65kA
	201A through 361A		100 kA	100 kA	100 kA
	480A		L	100 kA	100 kA

### Combination Circuit Breaker Soft Starter Units for Bulletin 2155H and 2155J

326

Bulletin Number	SMC Device Rating	Circuit Breaker Frame	Short Circuit Withstand Ratings (Amperes rms Symmetrical)		
			240V	480V	600V
2155H without Option 13HIC	3A through 43A	MCP, I3C, I6C	5kA	5kA	5kA
	60A and 85A	MCP, I3C, I6C, JD3D, JD6D	10kA	10kA	10kA
	108A and 135A	MCP, JD3D, JD6D	25kA	25kA	25kA
2155H with Option 13HIC	3A through 135A	MCP, I3C, I6C, JD3D, JD6D	100kA	100kA	100kA
2155J without Option 13HIC	5A through 85A	MCP, I3C, I6C, JD3D, JD6D	10kA	10kA	10kA
	108A through 135A	MCP, JD3D, JD6D	25kA	25kA	25kA
	201A through 480A	MCP, JD3D, JD6D, K3D, K6D, LD, HLD, MDL, HMDL	30kA	30kA	30kA
2155J with Option 13HIC	5A through 85A	MCP	100kA	100kA	100kA
		JD3D	18kA	14kA	14kA
		I3C	65kA	25kA	18kA
		I6C, JD6D	100kA	65kA	25kA
	108A through 135A	MCP, JD3D, JD6D	100kA	100kA	100kA
	201A through 480A	MCP, JD3D, JD6D, K3D, K6D, LD, HLD, MDL, HMDL	100kA	100kA	100kA

## Appendix

### UL/cUL/CSA Short Circuit Withstand Ratings for Combination Variable Frequency AC Motor Drive Units

#### AC Drive Combination Fusible Disconnect Units for Bulletins 2162Q, 2162R, 2162T, 2164Q, and 2164R

327

Fuse Class	Bulletin Number	Horsepower	Short Circuit Withstand Rating (Amperes rms Symmetrical)	
			480V	600V
CC, J	2162T	All ratings	100kA	100kA
J	2162Q, 2162R, 2164Q, 2164R	All ratings	100kA	100kA

#### AC Drive Combination Circuit Breaker Units for Bulletins 2163Q, 2163R, 2163T, 2165Q and 2165R

328

Circuit Breaker Frame	Drive Input Fuse Class	Bulletin Number	Horsepower	Short Circuit Withstand Ratings (Amperes rms Symmetrical)	
				480V	600V
MCP, I3C, I6C	CC, J	2163T	All ratings	100kA	100kA
MCP, I3C, I6C	J	2163Q, 2165Q	All ratings	100kA	100kA
MCP, I3C, I6C, JD3D, JD6D, K3D, K6D	J	2163R, 2165R	All ratings	100kA	100kA

### UL/cUL/CSA Short Circuit Withstand Ratings for Programmable Controllers

The following tables show short circuit capabilities for combination units that are UL listed and CSA certified.

329

Fuse Class	Bulletin Number	Short Circuit Withstand Ratings (Amperes rms Symmetrical)			
		240V	380-415V	480V	600V
CC	2182E	100kA	100kA	100kA	100kA
	2182J				
	2182L				

330

Circuit Breaker Frame	Bulletin Number	Short Circuit Withstand Ratings (Amperes rms Symmetrical)		
		240V	380-480V	600V
I3C	2183E	65kA	35kA	18kA
	2183J			
	2183L			
I6C	2183E	100kA	65kA	25kA
	2183J			
	2183L			
I3C-CL	2183E	100kA	100kA	100kA

## kW to Catalog HP Code Conversion for Bulletins 2106, 2107, 2112, 2113, 2122, 2123, 2126 and 2127

kW (For ratings other than those listed, use the next highest rating shown.)	Metric HP	Required NEMA HP Rating	Required Catalog HP Code
0.06	0.08	0.125	30
0.09	0.12	0.125	30
0.12	0.16	0.25	31
0.18	0.24	0.25	31
0.25	0.34	0.33	32
0.37	0.5	0.5	33
0.55	0.75	0.75	34
0.75	1	1	35
1.1	1.5	1.5	36
1.5	2	2	37
1.8	2.4	3	38
2.2	3	3	38
3	4	5	39
3.7	5	5	39
4	5.5	7.5	40
5.5	7.5	7.5	40
6.3	8.5	10	41
7.5	10	10	41
10	13.5	15	42
11	15	15	42
13	18	20	43
15	20	20	43
17	23	25	44
18.5	25	25	44
20	27	30	45

kW (For ratings other than those listed, use the next highest rating shown.)	Metric HP	Required NEMA HP Rating	Required Catalog HP Code
22	30	30	45
25	34	40	46
30	40	40	46
32	43	50	47
37	50	50	47
40	54	60	48
45	60	60	48
50	68	75	49
55	75	75	49
63	85	100	50
75	100	100	50
80	110	125	51
90	125	125	51
100	136	150	52
110	150	150	52
125	169	200	54
132	180	200	54
150	205	250	56
160	220	250	56
185	250	250	56
200	270	300	57
220	300	300	57
250	340	350	58
315	430	400	59

## Appendix

### Recommended Capacitor Sizes 480V and 600V

This table shows suggested capacitor ratings for T-frame NEMA Design B induction motors when the capacitor and motor are switched as a unit. It is based on normal starting current and torque.

332

Horsepower	3600 RPM	1800 RPM	1200 RPM	900 RPM
5	2 kVAR	2.5 kVAR	3 kVAR	4 kVAR
7.5	2.5 kVAR	3 kVAR	4 kVAR	5 kVAR
10	4 kVAR	4 kVAR	5 kVAR	6 kVAR
15	5 kVAR	5 kVAR	6 kVAR	7.5 kVAR
20	6 kVAR	6 kVAR	7.5 kVAR	9 kVAR
25	7.5 kVAR	7.5 kVAR	8 kVAR	10 kVAR
30	8 kVAR	8 kVAR	10 kVAR	15 kVAR
40	12.5 kVAR	15 kVAR	15 kVAR	17.5 kVAR
50	15 kVAR	17.5 kVAR	20 kVAR	22.5 kVAR
60	17.5 kVAR	20 kVAR	22.5 kVAR	25 kVAR
75	20 kVAR	25 kVAR	25 kVAR	30 kVAR
100	22.5 kVAR	30 kVAR	30 kVAR	35 kVAR
125	25 kVAR	35 kVAR	35 kVAR	40 kVAR
150	30 kVAR	40 kVAR	40 kVAR	50 kVAR
200	35 kVAR	50 kVAR	50 kVAR	70 kVAR
250	40 kVAR	60 kVAR	60 kVAR	80 kVAR
300	45 kVAR	70 kVAR	75 kVAR	100 kVAR
350	50 kVAR	75 kVAR	90 kVAR	120 kVAR
400	75 kVAR	80 kVAR	100 kVAR	130 kVAR
450	80 kVAR	90 kVAR	120 kVAR	140 kVAR
500	100 kVAR	120 kVAR	150 kVAR	160 kVAR

This table shows suggested capacitor ratings for U-frame NEMA Design B induction motors when the capacitor and motor are switched as a unit. It is based on normal starting current and torque.

333

Horsepower	3600 RPM	1800 RPM	1200 RPM	900 RPM
5	2 kVAR	2 kVAR	2 kVAR	3 kVAR
7.5	2.5 kVAR	2.5 kVAR	3 kVAR	4 kVAR
10	3 kVAR	3 kVAR	3 kVAR	5 kVAR
15	4 kVAR	4 kVAR	5 kVAR	6 kVAR
20	5 kVAR	5 kVAR	6 kVAR	7.5 kVAR
25	6 kVAR	6 kVAR	7.5 kVAR	9 kVAR
30	7 kVAR	7 kVAR	9 kVAR	10 kVAR
40	9 kVAR	9 kVAR	10 kVAR	12.5 kVAR
50	12.5 kVAR	10 kVAR	12.5 kVAR	15 kVAR
60	15 kVAR	15 kVAR	15 kVAR	17.5 kVAR
75	17.5 kVAR	17.5 kVAR	17.5 kVAR	20 kVAR
100	22.5 kVAR	20 kVAR	25 kVAR	27.5 kVAR
125	27.5 kVAR	25 kVAR	30 kVAR	30 kVAR
150	30 kVAR	30 kVAR	35 kVAR	37.5 kVAR
200	40 kVAR	37.5 kVAR	40 kVAR	50 kVAR
250	50 kVAR	45 kVAR	50 kVAR	60 kVAR
300	60 kVAR	50 kVAR	60 kVAR	60 kVAR
350	60 kVAR	60 kVAR	75 kVAR	75 kVAR
400	75 kVAR	60 kVAR	75 kVAR	85 kVAR
450	75 kVAR	75 kVAR	80 kVAR	90 kVAR
500	75 kVAR	75 kVAR	85 kVAR	100 kVAR

## Horsepower Ratings for Bulletin 2192F, Fusible Disconnect Feeder Switch (FDS) Units

334

Switch Ratings (Amperes)	Horsepower at Rated Motor Voltage				
	200V	230V	380-415V	460V	575V
30	0.125-7.5	0.125-7.5	0.125-15	0.125-15	0.125-20
60	10-15	10-15	20-30	20-30	25-40
100	20-25	20-30	40-50	40-50	50
200	30-50	40-60	60-100	60-125	60-150
400	60-100	75-125	125-250	150-250	175-350
600	125-150	150-200	300-350	300-400	400

### Conductor Size Conversion Chart— Metric Conductor Size to American Wire Gauge Conductor Size

335

Metric Conductor Size	American Wire Gauge Size <sup>[1]</sup> (actual size in mm <sup>2</sup> )
1.0 mm <sup>2</sup>	#18 (0.823)
1.5 mm <sup>2</sup>	#16 (1.31)
2.5 mm <sup>2</sup>	#14 (2.68)
4 mm <sup>2</sup>	#12 (3.31)
6 mm <sup>2</sup>	#10 (5.26)
10 mm <sup>2</sup>	#8 (8.37)
16 mm <sup>2</sup>	#6 (13.30)
25 mm <sup>2</sup>	#4 (21.13)
25 mm <sup>2</sup>	#3 <sup>[2]</sup> (26.67)
35 mm <sup>2</sup>	#2 (33.62)
35 mm <sup>2</sup>	#1 <sup>[2]</sup> (44.21)
50 mm <sup>2</sup>	#1/0 (53.49)
70 mm <sup>2</sup>	#2/0 (67.43)
95 mm <sup>2</sup>	#3/0 (85.01)
95 mm <sup>2</sup>	#4/0 <sup>[2]</sup> (107.20)
120 mm <sup>2</sup>	250 kcmil (127.0)
150 mm <sup>2</sup>	300 kcmil (152.0)
185 mm <sup>2</sup>	350 kcmil (177.0)
185 mm <sup>2</sup>	400 kcmil <sup>[2]</sup> (203.0)
240 mm <sup>2</sup>	500 kcmil (253.0)
300 mm <sup>2</sup>	600 kcmil (304.0)
400 mm <sup>2</sup>	750 kcmil (350.0)

[1] Reference IEC Standard 60947-1, table I.

[2] This American wire gauge conductor size is the closest equivalent to the metric conductor size.

## Appendix

### Metric Conversion Table

336

English Measurement (inches)	Metric Equivalent (millimeter)	English Measurement (inches)	Metric Equivalent (millimeter)
0.016	0.40	1	25.40
0.031	0.79	2	50.80
0.063	1.59	3	76.20
0.094	2.38	4	101.60
0.125	3.18	5	127.00
0.156	3.97	6	152.40
0.188	4.76	7	177.80
0.218	5.56	8	203.20
0.250	6.35	9	228.60
0.281	7.14	10	254.00
0.313	7.94	20	508.00
0.375	9.53	30	762.00
0.438	11.11	40	1016.00
0.500	12.70	50	1270.00
0.563	14.29	60	1524.00
0.625	15.88	70	1778.00
0.688	17.46	80	2032.00
0.750	19.05	90	2286.00
0.875	22.23	100	2540.00
0.938	23.81	200	5080.00

1 inch = 2.54 centimeters

1 foot = 12 inches

1 centimeter = 10 millimeters

## Fan(s) and Ventilation in Bulletins 2154H, 2154J, 2155H and 2155J

	System Voltage	NEMA Enclosure Type	Rating Code	Venting	Door Mounted Exhaust Fan(s)
Bulletins 2154H and 2155H	All	1, 1G	A, B, D, E, F, G (3 to 37 Ampere)	No	No
	All	1, 1G	H, J, K, L, M (43 to 135 Ampere)	Yes	Yes
	All	12	A, B, D, E, F, G, H, J, K (3 to 85 Ampere)	No	No
	All	12	L, M (108 to 135 Ampere)	Yes	Yes (filtered and gasketed)
Bulletins 2154J and 2155J	All	1, 1G	F005 to F135 (5 to 135 Ampere)	Yes	Yes
	All	1, 1G	F201 to F480 (201 to 480 Ampere)	No	No
	All	12	F005 to F135 (5 to 135 Ampere)	Yes	Yes (filtered and gasketed)
	All	12	F201 to F480 (201 to 480 Ampere)	No	No

Fan(s) and Ventilation in Bulletins 2162Q, 2162R, 2163Q and 2163R

	System Voltage	NEMA Enclosure Type	Rating Code	Venting	Internal Circulating Fan(s)	Door Mounted Exhaust Fan(s)	
Bulletins 2162Q and 2163Q	380-415V	1, 1G	1P3 - 5P0	Yes	None	Yes	
			8P7 - 072	Yes	None	Yes	
		12	1P3 - 022	None	Yes	None	
			030	Yes (filtered and gasketed)	None	Yes (filtered and gasketed)	
			037 - 072	Yes (filtered and gasketed)	Yes	Yes (filtered and gasketed)	
	480V	1, 1G	1P1 - 3P4	Yes	None	None	
			5P0	Yes	None	Yes [1]	
			8P0 - 065	Yes	None	Yes	
		12	1P1 - 2P1	None	None	None	
			3P4 - 022	None	Yes	None	
			027	Yes (filtered and gasketed)	None	Yes (filtered and gasketed)	
	600V	1, 1G	0P9 - 2P7	Yes	None	None	
			3P9 - 052	Yes	None	Yes [1]	
		12	0P9 - 1P7	None	None	None	
			2P7 - 017	None	Yes	None	
			022 - 052	Yes (filtered and gasketed)	None	Yes (filtered and gasketed)	
	Bulletins 2162R and 2163R	380 - 415V	1, 1G	1P3 - 5P0	Yes	None	None
				8P7 - 030	Yes	None	Yes
037 - 056				Yes	None	Yes	
072 - 300				Yes	None	Yes	
12			1P3 - 043	None	Yes	None	
			056 - 072	Yes (filtered and gasketed)	Yes	Yes (filtered and gasketed)	
			105 - 170	Yes (filtered and gasketed)	None	Yes (filtered and gasketed)	
480V		1, 1G	1P1 - 5P0	Yes	None	None	
			8P0 - 300	Yes	None	Yes	
		12	1P1 - 034	None	Yes	None	
			040 (without reactor)	None	Yes	None	
			040 (with reactor)	Yes (filtered and gasketed)	Yes	Yes (filtered and gasketed)	
			052 - 065	Yes (filtered and gasketed)	Yes	Yes (filtered and gasketed)	
600		1, 1G	096 - 180	Yes (filtered and gasketed)	None	Yes (filtered and gasketed)	
			1P7 - 3P9	Yes	None	None	
		12	6P1 - 144	Yes	None	Yes	
			1P7 - 027	None	Yes	None	
			032 (without reactor)	None	Yes	None	
032 (with reactor)	Yes (filtered and gasketed)	Yes	Yes (filtered and gasketed)				
041 - 144	Yes (filtered and gasketed)	None	Yes (filtered and gasketed)				

[1] If -14RLX or -14RXL is specified for the 3.9A @ 600V or 5.0A @ 480V unit, the unit door will be supplied with input and exhaust venting.

## Fan(s) and Ventilation in Bulletins 2164Q and 2165Q

	System Voltage	NEMA Enclosure Type	Current Rating (Amperes)	Venting	Internal Circulating Fan(s)	Door Mounted Exhaust Fan(s)
Bulletins 2164Q and 2165Q	480	1, 1G	1.1-27	Yes	None	Yes
		12	1.1-22	None	Yes	None
			27	Yes (filtered and gasketed)	None	Yes (filtered and gasketed)
	600	1, 1G	0.9-22	Yes	None	Yes
		12	0.9-17	None	Yes	None
			22	Yes (filtered and gasketed)	None	Yes (filtered and gasketed)

## Fan(s) and Ventilation in Bulletins 2164R and 2165R

	System Voltage	NEMA Enclosure Type	Current Rating (Amperes)	Venting	Internal Circulating Fan(s)	Door Mounted Exhaust Fan(s)
Bulletins 2164R and 2165R	480	1, 1G	1.1 - 180	Yes	None	Yes
		12	1.1 - 40 <sup>[1]</sup>	None	Yes	None
			52 - 65	Yes (filtered and gasketed)	Yes	Yes (filtered and gasketed)
			77 - 180	Yes (filtered and gasketed)	None	Yes (filtered and gasketed)
	600	1, 1G	1.7 - 144A	Yes	None	Yes
		12	1.7 - 32 <sup>[2]</sup>	None	Yes	None
			41 - 52	Yes (filtered and gasketed)	Yes	Yes (filtered and gasketed)
			62 - 144A	Yes (filtered and gasketed)	None	Yes (filtered and gasketed)

[1] Door mounted exhaust fan (filtered and gasketed) added when line or load reactor is added to 40A unit.

[2] Door mounted exhaust fan (filtered and gasketed) added when line or load reactor is added to 32A unit.

## Fan(s) and Ventilation in Bulletins 2162T and 2163T

	System Voltage	NEMA Enclosure Type	Current Rating (Amperes)	Venting	Internal Circulating Fan(s)	Door Mounted Exhaust Fan(s)
Bulletins 2162T and 2163T	380-415	1, 1G	1.4 - 24	Yes	None	Yes
		12	1.4 - 2.3 <sup>[1]</sup>	None	None <sup>[1]</sup>	None
			4.0 - 24	None	Yes	None
	480	1, 1G	1.4 - 24	Yes	None	Yes
		12	1.4 - 2.3 <sup>[1]</sup>	None	None <sup>[1]</sup>	None
			4.0 - 24	None	Yes	None
	600	1, 1G	1.7 - 19	Yes	None	Yes
		12	1.7 <sup>[2]</sup>	None	None <sup>[2]</sup>	None
			3.0 - 19	None	Yes	None

[1] When line or load reactors are specified in 2.3A drive unit, an internal circulating fan is added.

[2] When line or load reactors are specified in 1.7A drive unit, an internal circulating fan is added.

**Control Circuit Transformer Rating Chart for Bulletins 2182E, 2182L, 2183E and 2183L**

Rack Size	Space Factor	Power Supply Type			
		None, 12P4S1, 12P4S2, 12P4R2 or 12PA72	12P2	12P7	12P4R3 or 12P4R4
(1) 4-slot	1.5	250 VA	—	—	—
	2.0	250 VA	—	—	—
	3.0	250 VA	250 VA	—	—
(1) 7-slot	2.0	250 VA	—	—	—
(1) 8-slot	2.5	250 VA	—	—	—
	3.0	250 VA	250 VA	—	—
(1) 8-slot	6.0, 25" W	(1) 250 VA	(1) 250VA	(1) 500VA	—
(2) 8-slot	6.0, 25" W	(2) 250 VA	(2) 250 VA	(2) 500 VA	—
(1) 16-slot	6.0, 35" W	250 VA	250 VA	500 VA	500 VA
(2) 16-slot	6.0, 35" W	(2) 250 VA	(2) 250 VA	(2) 500 VA	(2) 500 VA
(1) 16-slot	6.0, 40" W	250 VA	—	500 VA	500 VA
(2) 16-slot	6.0, 40" W	500 VA	—	1 kVA	1 kVA

**Seismic Applications**

Actual CENTERLINE 2100 Motor Control Center (MCC) samples have been seismically qualified by dynamic (triaxial multi-frequency testing) seismic tests per IEEE 344 Seismic Test Standards. The results of this MCC seismic testing demonstrated compliance with the 100% g level of Uniform Building Code 1997 (UBC) Zone 4 (the maximum UBC Zone) and 100% g level of the International Building Code 2006 (IBC), i.e., the MCC structure, the MCC units, the MCC components or electrical functions were not compromised when subjected to a UBC Zone 4 earthquake or the IBC seismic event. Per the IEEE 344 Standard, the equipment was under power and operated before, during and after the seismic tests.

To obtain a UBC or IBC seismic withstandability, each individual CENTERLINE 2100 MCC line-up (e.g., both front and back MCCs in "back-to-back" applications) must be mounted on an adequate seismic foundation and installed per the seismic anchoring requirements as indicated in publication 2100-IN012x-EN-P, CENTERLINE 2100 Motor Control Centers User Manual.

**Note:** Variable frequency drive units utilizing "rollout" drive configurations are not seismically certified.

## Power System Configuration Application Information

CENTERLINE 2100 Motor Control Centers are suitable for use on 3-phase, 3-wire or 4-wire, Wye connected power systems, rated 600V or less, 50 or 60 hertz, which have a solidly grounded neutral. CENTERLINE 2100 Motor Control Centers may also be used on the following power system configurations, however, some units and options may not be available:

- 3-phase, 3-wire, Wye systems rated 600Y/347V or less, with impedance grounded neutral
- 3-phase, 3-wire, ungrounded Delta systems, rated 600V or less

For 3-phase, 3-wire, "corner" grounded, Delta systems, 3-phase, 4-wire, center-tap-grounded, "high-leg", Delta systems rated 240V, and any other power systems not listed above, the MCCs will be processed on the Engineered delivery program to help ensure proper product configuration.

**Note:** for more information regarding MCC selection criteria related to power system configurations, see publication 2100-AT003x-EN-P, *Power System Considerations for Selection of CENTERLINE 2100 Motor Control Centers*.

### Horizontal Neutral Bus and Neutral Bus Options

Neutral bus and options are only available for 3-phase, 4-wire WYE connected power systems with the neutral solidly grounded. Neutral bus options may not be selected for any ungrounded system or for any system that is impedance grounded.

If a 4-wire system is selected, a determination needs to be made regarding neutral loads

No Neutral loads or neutral loads less than 280 Amp

Option 88NPC is available for 2191M rated 300A, 2192M rated 400A or less, and 2193M with 400A frame or smaller.

For 2191M rated 600A or larger, 2192M rated 600A or larger, and 2193M with 600A frame or larger, horizontal neutral bus and incoming option -88HN or -88FN must be selected.

**NOTE:** If complete horizontal neutral is not required, horizontal neutral bus is allowed to be specified for only the section containing the Bulletin 2191M, 2192M, or 2193M main unit and up to three additional adjacent sections. However, the sections with the neutral bus need to be in their own shipping blocks. If neutral loads are present, then access to the horizontal neutral bus for neutral load cables is required. At least one neutral connection plate in the horizontal wireway or one vertical neutral in a 9" vertical wireway is required.

### Neutral Loads greater than 280 Amp

For 4 wire system with neutral loads *greater than 280A*, horizontal neutral bus and incoming option -88HN or -88FN must be selected. In addition, at least one neutral connection plate in the horizontal wireway or one vertical neutral in a 9" vertical wireway *is required*.

**NOTE:** If any single neutral load is greater than 280A, the MCC needs to be processed on the Engineered delivery program to provide an appropriate neutral connection point for the neutral load cable.

### Any units with fusible disconnect switches

No restrictions for Wye connected systems or ungrounded Delta systems.

### Any units with circuit breaker disconnects

No restrictions for Wye connected systems or ungrounded Delta systems.

### Bulletin 2190 Units and Bulletin 2191 Units with Metering

Analog metering units are available for:

3-phase, 3-wire solidly grounded Wye

3-phase, 3-wire ungrounded, closed-Delta

Digital metering units are available for:

3-phase, 3-wire solidly grounded Wye

3-phase, 4-wire solidly grounded Wye

Metering for other systems is available on the Engineered delivery program.



# Index

## Numerics

100% Rating of Main Disconnect Switch or Circuit Breaker **122**  
71" High Section **24**  
8A Round DeviceNet Cable **220**

## A

ABS **2**  
Additional Unit Space on Contactors and Starters, Metering, Mains and Feeders, Lighting and Power Panels, and Transformer Units **114**  
American Bureau of Shipping **3**  
Analog Output Isolation on Combination Variable Frequency AC Motor Drive Units **190**  
Appendix **221**  
Automatic Shutters **28**  
Auxiliary Contacts on Combination Soft Starter Controller Units **143**  
Auxiliary Contacts on Combination Variable Frequency AC Motor Drive Units **193**  
Auxiliary Contacts on Contactors and Starters, Metering, Mains and Feeders, Lighting and Power Panels, and Transformer Units **120, 128**  
Auxiliary Contacts on Marshalling Panels and Programmable Controllers **203**  
Auxiliary Contacts on SC-I and PE-I **23**

## B

Back-to-Back Section **24**  
Blank Unit Door **102**  
Blown Fuse Indicator Lights on Contactors and Starters, Metering, Mains and Feeders, Lighting and Power Panels, and Transformer Units **115**  
Bolt-on Inverse Time (Thermal Magnetic) Branch Breakers for Lighting Panels **219**  
Bottom Closing Plate **24, 213**  
Bulletin  
    2100D Empty Unit Insert with Disconnect Switch **102**  
    2100M Empty Unit Insert with Circuit Breaker **102**  
    2100N Empty Unit Insert without power stabs **102**  
    2102L, Full Voltage Lighting Contactor Unit with Fusible Disconnect Switch (FVLC) **36**  
    2103L, Full Voltage Lighting Contactor Unit with Circuit Breaker (FVLC) **37**  
    2106, Full Voltage Reversing Starter Unit with Fusible Disconnect Switch (FVR) **39**  
    2106, Space Saving NEMA Full Voltage Reversing Starter Unit with Fused Disconnect Switch (FVR) **41**  
    2107, Full Voltage Reversing Starter Unit with Circuit Breaker (FVR) **39**  
    2107, Space Saving NEMA Full Voltage Reversing Starter Unit with Circuit Breaker (FVR) **41**  
    2112, Full Voltage Non-Reversing Starter Units with Fusible Disconnect Switch (FVNR) **43**  
    2112, Space Saving NEMA Full Voltage Non-Reversing Starter Unit with Fused Disconnect Switch (FVNR) **47**  
    2113, Full Voltage Non-Reversing Starter Unit with Circuit Breaker (FVNR) **45**  
    2113, Space Saving NEMA Full Voltage Non-Reversing Starter Unit with Circuit Breaker (FVNR) **47**

2122E, Two Speed 2-Winding Starter Unit with Fusible Disconnect Switch (TS2W) **49**  
2122F, Two Speed 1-Winding Starter Unit with Fusible Disconnect Switch (TS1W) **50**  
2123E, Two Speed 2-Winding Starter Unit with Circuit Breaker (TS2W) **51**  
2123F, Two Speed 1-Winding Starter Unit with Circuit Breaker (TS1W) **51**  
2126E, Two Speed Reversing 2-Winding Starters with Fusible Disconnect Switch (TSR2W) **53**  
2126F, Two Speed Reversing 1-Winding Starter Unit with Fusible Disconnect Switch (TSR1W) **53**  
2126J, Two Speed Reversing in Low Speed Only 2-Winding Starter Unit with Fusible Disconnect Switch (TSR2W) **54**  
2126K, Two Speed Reversing in Low Speed Only 1-Winding Starter Unit with Fusible Disconnect Switch (TSR1W) **54**  
2127E, Two Speed Reversing 2-Winding Starter Unit with Circuit Breaker (TSR2W) **55**  
2127F, Two Speed Reversing 1-Winding Starter Unit with Circuit Breaker (TSR1W) **55**  
2127J, Two Speed Reversing in Low Speed Only 2-Winding Starter Unit with Circuit Breaker (TSR2W) **56**  
2127K, Two Speed Reversing in Low Speed Only 1-Winding Starter Unit with Circuit Breaker (TSR1W) **56**  
2154H, Combination Soft Starter Motor Controller with Fusible Disconnect Switch (SMC-3) **131**  
2154J, Combination Soft Starter Motor Controller with Fusible Disconnect Switch (SMC-Flex) **134**  
2155H, Combination Soft Starter Motor Controller with Circuit Breaker (SMC-3) **132**  
2155J, Combination Soft Starter Motor Controller with Circuit Breaker (SMC-Flex) **135**  
2162Q, Combination PowerFlex 70 Variable Frequency AC Drive (VFD) Units with Fusible Disconnect, 380-480V **150, 151, 152, 153, 154, 155, 156, 157, 158, 159**  
2162R, Combination PowerFlex 700 Variable Frequency AC Drive (VFD) Units with Fusible Disconnect, 380-480VAC **161, 162, 163, 164, 165, 169, 170**  
2162T, Combination PowerFlex 40 Variable Frequency AC Drive (VFD) Units with Fusible Disconnect, 380-480VAC **172**  
2162T, Combination PowerFlex 40 Variable Frequency AC Drive (VFD) Units with Fusible Disconnect, 600VAC **173**  
2163R, Combination PowerFlex 700 Variable Frequency AC Drive (VFD) Units with Circuit Breaker, 380-480VAC **166, 167, 168**  
2163T, Combination PowerFlex 40 Variable Frequency AC Drive (VFD) Units with Fusible Disconnect, 380-480VAC **174**  
2163T, Combination PowerFlex 700 Variable Frequency AC Drive (VFD) Units with Fusible Disconnect, 600VAC **175**  
2164Q, Combination PowerFlex 70 Variable Frequency AC Drive (VFD) with Fusible Disconnect and Manual, Isolated Bypass, 480V **177**  
2164Q, Combination PowerFlex 70 Variable Frequency AC Drive (VFD) with Fusible Disconnect and Manual, Isolated Bypass, 600V **178**

- 2164R, Combination PowerFlex 700 Variable Frequency AC Drive (VFD) with Fusible Disconnect and Manual, Isolated Bypass, 480VAC **182**
- 2164R, Combination PowerFlex 700 Variable Frequency AC Drive (VFD) with Fusible Disconnect and Manual, Isolated Bypass, 600VAC **183, 185**
- 2165Q, Combination PowerFlex 70 Variable Frequency AC Drive (VFD) with Circuit Breaker Disconnect and Manual, Isolated Bypass, 480V **179**
- 2165Q, Combination PowerFlex 70 Variable Frequency AC Drive (VFD) with Circuit Breaker Disconnect and Manual, Isolated Bypass, 600V **180**
- 2165R, Combination PowerFlex 700 Variable Frequency AC Drive (VFD) with Circuit Breaker Disconnect and Manual, Isolated Bypass, 480VAC **184**
- 2180E, 2182E, and 2183E, Bulletin 1771 Programmable Controller I/O Chassis (PLC) **198**
- 2180J, 2182J, and 2183J, Bulletin 1746 SLC 500 Programmable Controller (PLC) **199**
- 2180L, 2182L, and 2183L, Bulletin 1756 ControlLogix Programmable Controller (PLC) **200**
- 2181B, Marshalling Panel **202**
- 2190, Metering Compartments (METER) **58, 60**
- 2191M and 2191F, Lug Compartments—Provisions for Basic Sections/Incoming Lines (MLUG) and Outgoing Feeders (FLUG) **63**
- 2191M, Lug Compartments/Incoming Line—Dimensions **67, 68**
- 2191M, Lug Compartments/Incoming Lines Metering Options **66**
- 2192F, Fusible Disconnect Switch—Feeders (FDS) **70**
- 2192M, Fusible Disconnect Switch—Mains (MFDS) **71**
- 2193F, 3-Pole Feeder Circuit Breaker (FCB) **74, 75, 76**
- 2193LE, Frame-Mounted Lighting Panel for Bolt-on Branch Circuit Breakers (LPAN) **83**
- 2193M, 3-Pole Main Circuit Breaker (MCB) **77, 78, 79, 80**
- 2193PP, Plug-in Panel Board with Main Circuit Breaker (PPAN) **85**
- 2195, Control and Lighting Transformer Unit without Disconnecting Means (XFMR) **89, 90**
- 2196, Control and Lighting Transformer Unit with Fusible Disconnect Switch (XFMR) **91, 92, 93, 94**
- 2197, Control and Lighting Transformer Unit with Circuit Breaker (XFMR) **95, 96, 97, 98**
- Bus Bracing **26**
- Bus Stab Isolation Kit **214**
- C**
- Capacitor Sizes **240**
- Cardholder for Unit Doors **216**
- CE Marking **2**
- Circuit Breaker Characteristics for Bulletin 2193F and 2193M Units **234**
- Circuit Breaker Interrupting Capacity Ratings **234**
- Circuit Breaker on Contactors and Starters, Metering, Mains and Feeders, Lighting and Power Panels, and Transformer Units **122**
- Circuit Breaker Suffix Letter Designation **9**
- Circuit Breaker Type
  - for Bulletins 2107, 2113, 2123, and 2127 **211**
  - for Bulletins 2163, and 2165 **212**
  - for Horsepower and kW Rated Units for Bulletins 2155 **212**
- Inverse Time (Thermal Magnetic or Solid State) Circuit Breaker Options for Bulletin 2103L **210**
- Inverse Time (Thermal Magnetic) Circuit Breaker Options for Bulletin 2197 **211**
- Communication Module on Combination Soft Starter Controller Units **140**
- Communication Modules on Combination Variable Frequency AC Motor Drive Units **188**
- Conductor Size Conversion Chart **241**
- Contactors and Starters
  - Catalog Number Explanations **35, 57, 62, 69, 73, 82, 84, 88, 99, 130, 133, 201**
- Control Circuit Fuse on Contactors and Starters, Metering, Mains and Feeders, Lighting and Power Panels, and Transformer Units **114**
- Control Circuit Lugs on Contactors and Starters, Metering, Mains and Feeders, Lighting and Power Panels, and Transformer Units **122**
- Control Circuit Ring Lugs on Combination Soft Starter Controller Units **144**
- Control Circuit Spade Lugs on Combination Soft Starter Controller Units **144**
- Control Circuit Transformer on Contactors and Starters, Metering, Mains and Feeders, Lighting and Power Panels, and Transformer Units **110, 126**
- Control Circuit Transformer Rating Chart **246**
- Control Circuit Wiring on Combination Soft Starter Controller Units **144**
- Control Circuit Wiring on Combination Variable Frequency AC Motor Drive Units **193**
- Control Circuit Wiring on Contactors and Starters, Metering, Mains and Feeders, Lighting and Power Panels, and Transformer Units **122**
- Control Station Housing **216**
- Control Station Housing on Combination Soft Starter Controller Units **137**
- Control Station Housing on Contactors and Starters, Metering, Mains and Feeders, Lighting and Power Panels, and Transformer Units **107**
- Control Station Mounting Plate **216**
- Control Terminal Block on Contactors and Starters, Metering, Mains and Feeders, Lighting and Power Panels, and Transformer Units **121**
- Control Voltage Type
  - for Bulletins 2102, 2103, 2106, 2107, 2112, 2113, 2122, 2123, 2126, and 2127 **205**
  - for Bulletins 2154 and 2155 **205**
  - for Bulletins 2162, 2163, 2164, and 2165 **206**
- Control Wire Markers on Combination Soft Starter Controller Units **144**
- Control Wire Markers on Combination Variable Frequency AC Motor Drive Units **193**
- Control Wire Markers on Contactors and Starters, Metering, Mains and Feeders, Lighting and Power Panels, and Transformer Units **122, 204**
- ControlLogix Communication Modules on Marshalling Panels and Programmable Controllers **203**
- ControlLogix Processor on Marshalling Panels and Programmable Controllers **203**
- ControlLogix Programming Cable on Marshalling Panels and Programmable Controllers **203**
- ControlNet to DeviceNet Linking Device **104**

- ControlNet T-Tap on Marshalling Panels and Programmable Controllers **203**
- Corner Section **24**
- CSA Marking **1**
- C-UL Marking **1**
- Current Sensors on Contactors and Starters, Metering, Mains and Feeders, Lighting and Power Panels, and Transformer Units **121**
- Current Transducers on Contactors and Starters, Metering, Mains and Feeders, Lighting and Power Panels, and Transformer Units **121**
- D**
- Delivery Programs **3**
- DeviceNet
- Cabling Options **29**
  - Hardware and Kits **220**
  - Miscellaneous Units **104**
  - Products **3**
- DeviceNet Communication Module on Combination Soft Starter Controller Units **140**
- DeviceNet Communication Modules on Combination Variable Frequency AC Motor Drive Units **188**
- DeviceNet Connection Cover Kit **220**
- DeviceNet Field Support Kit **220**
- DeviceNet Scanner Module on Marshalling Panels and Programmable Controllers **203**
- DeviceNet Scanner Modules **220**
- DeviceNet Starter Auxiliary on Combination Soft Starter Controller Units **140**
- DeviceNet Starter Auxiliary on Contactors and Starters, Metering, Mains and Feeders, Lighting and Power Panels, and Transformer Units **114**
- DeviceNet Terminating Resistors **220**
- DeviceNet Trunk Line Cable **220**
- DeviceNet Unit Cable **220**
- Dimensions **221**
- Documentation **3**
- Door Hardware Kit **216**
- Door Hinge Kit **216**
- Door, Blank **102**
- Drip Hood **24, 213**
- E**
- E3 Solid-State Overload Relay on Contactors and Starters, Metering, Mains and Feeders, Lighting and Power Panels, and Transformer Units **113**
- Elapsed Time Meter on Contactors and Starters, Metering, Mains and Feeders, Lighting and Power Panels, and Transformer Units **116**
- Empty Unit Insert **102**
- Empty Unit Insert with Disconnecting Means **102**
- End Closing Plate **213**
- Ethernet to DeviceNet Linking Device **104**
- Export Packing Below Deck for Sections on SC-I and PE-I **23**
- Export Packing Below Deck on Combination Soft Starter Controller Units **144**
- Export Packing Below Deck on Combination Variable Frequency AC Motor Drive Units **193**
- Export Packing Below Deck on Contactors and Starters, Metering, Mains and Feeders, Lighting and Power Panels, and Transformer Units **123**
- Export Packing Below Deck on Marshalling Panels and Programmable Controllers **204**
- Extended Reset Button Kit **217**
- External Auxiliary Contact **217**
- External Auxiliary Contact Adapter Kits **217, 218**
- External Auxiliary Contact Kits **218**
- External DeviceNet Connector Unit **104**
- External DeviceNet Connector with 120VAC Receptacle on Contactors and Starters, Metering, Mains and Feeders, Lighting and Power Panels, and Transformer Units **123**
- External Mounting Channel Kits **213**
- F**
- Fan(s) and Ventilation
- in Bulletins 2154H, 2154J, 2155H, and 2155J **243**
  - in Bulletins 2162Q, 2162R, 2163Q, and 2163R **244**
  - in Bulletins 2162T and 2163T **245**
  - in Bulletins 2164Q and 2165Q **245**
  - in Bulletins 2164R and 2165R **245**
- Field-Mounted Equipment Units **102**
- Filters for Door Vents on Contactors and Starters, Metering, Mains and Feeders, Lighting and Power Panels, and Transformer Units **114**
- Footnotes **1**
- French Legend Plates on Combination Soft Starter Controller Units **144**
- French Legend Plates on Combination Variable Frequency AC Motor Drive Units **193**
- French Legend Plates on Contactors and Starters, Metering, Mains and Feeders, Lighting and Power Panels, and Transformer Units **123**
- Full Load Currents **232, 233**
- Fuse Clip Designator Selection, and Power Fuse Selection
- for Bulletins 2100D, 2102L, 2192F, and 2192M **208**
  - for Bulletins 2106, 2112, 2122, 2126, and 2127 **207**
- G**
- Gasketing Kit **213**
- Ground Detection Lights on Contactors and Starters, Metering, Mains and Feeders, Lighting and Power Panels, and Transformer Units **116**
- Ground Fault Protection on Contactors and Starters, Metering, Mains and Feeders, Lighting and Power Panels, and Transformer Units **116**
- Ground Lug, Outgoing **28**
- Grounded Unit Door on Combination Soft Starter Controller Units **142**
- Grounded Unit Door on Combination Variable Frequency AC Motor Drive Units **193**
- Grounded Unit Door on Contactors and Starters, Metering, Mains and Feeders, Lighting and Power Panels, and Transformer Units **116**
- Grounded Unit Door on Marshalling Panels and Programmable Controllers **203**
- Grounded Unit Door on SC-I and PE-I **23**
- H**
- Hardware and Kits
- 8A Round DeviceNet Cable **220**
  - Bolt-on Inverse Time (Thermal Magnetic) Branch Breakers for Lighting Panels **219**
  - Bottom Closing Plate **213**
  - Bus Stab Isolation Kit **214**
  - Cardholder for Unit Doors **216**
  - Control Station Housing **216**
  - Control Station Mounting Plate **216**

DeviceNet Connection Cover Kit 220  
 DeviceNet Field Support Kit 220  
 DeviceNet Scanner Modules 220  
 DeviceNet Terminating Resistors 220  
 DeviceNet Trunk Line Cable 220  
 DeviceNet Unit Cable 220  
 Door Hardware Kit 216  
 Door Hinge Kit 216  
 Drip Hood 213  
 End Closing Plate 213  
 Extended Reset Button Kit 217  
 External Auxiliary Contact 217  
 External Auxiliary Contact Adapter Kits 217, 218  
 External Auxiliary Contact Kits 218  
 External Mounting Channel Kits 213  
 Gasketing Kit 213  
 Horizontal Ground Bus Splice Kit 214  
 Horizontal Power Bus Splice Kit 214  
 Horizontal Wireway Cover 213  
 Incoming Line Lug Barriers 215  
 Inverse Time (Thermal Magnetic) Branch Breakers for Panel Board Plug-In Unit 219  
 Line Terminal Shield 217  
 Lugs for Incoming Line Provisions 215  
 MCC DeviceNet Terminating Resistor Kit 220  
 Neutral Connection Plate Kit 214  
 NO-OX-ID 214  
 Plug-In Unit Retrofit Kit 217  
 Pull-Apart Terminal Blocks 217  
 Pullbox 213  
 Round DeviceNet Cable with Connectors 220  
 Space Heater Kit 213  
 Stainless Steel Nameplate Screws 216  
 Top Horizontal Wireway Pan 213  
 Touch-Up Paint 214  
 Unit Door Grounding Kit 217  
 Unit Door Nameplates 216  
 Unit Insert Extension Kit 217  
 Unit Isolating Barriers 214  
 Unit Operating Handle Extender 213  
 Unit Support Pan 216  
 Vertical Ground Bus Kit 214  
 Vertical Unit Load Ground Bus Kit 214  
 Vertical Wireway Tie Bar 214  
 Wiring Diagram Holder Kit 214  
 Heater Element Selection 227  
 Heater Element Selection Tables 229, 232  
 Horizontal Ground Bus 26  
 Horizontal Ground Bus Splice Kit 214  
 Horizontal Power Bus on Marshalling Panels and Programmable Controllers 204  
 Horizontal Power Bus Splice Kit 214  
 Horizontal Wireway Cover 213  
 Horsepower Ratings 241  
 Horsepower Ratings for All Bulletins 206  
 Human Interface Module (HIM) on Combination Soft Starter Controller Units 140

Human Interface Module (HIM) on Combination Variable Frequency AC Motor Drive Units 189  
**I**  
 I/O Control Voltage on Combination Variable Frequency AC Motor Drive Units 190  
 IEC 60439 2  
 Incoming Line Lug Barriers 215  
 Incoming Lug Compartments 63  
 Incoming Neutral Bus on Contactors and Starters, Metering, Mains and Feeders, Lighting and Power Panels, and Transformer Units 117  
 Incoming Neutral Connection Plate on Contactors and Starters, Metering, Mains and Feeders, Lighting and Power Panels, and Transformer Units 117  
 IntelliCENTER Technology  
     Motor Control Center 29  
     Software 30  
 Interposing Relay on Contactors and Starters, Metering, Mains and Feeders, Lighting and Power Panels, and Transformer Units 118  
 Inverse Time (Thermal Magnetic) Branch Breakers for Panel Board Plug-In Unit 219  
 ISO 9001 Certification 1  
 Isolation Contactor on Combination Soft Starter Controller Units 141  
**K**  
 Key-interlock Mounting Provision on Contactors and Starters, Metering, Mains and Feeders, Lighting and Power Panels, and Transformer Units 121  
 kW Ratings for Bulletins 2154, 2155, 2162, 2163, 2164, and 2165 206  
 kW to Catalog Hp Code Conversion 239  
**L**  
 Light and Door Switch on Marshalling Panels and Programmable Controllers 204  
 Line or Load Reactors on Combination Variable Frequency AC Motor Drive Units 191  
 Line Reactor Space Factor Adders 192, 193  
 Line Terminal Shield 217  
 Lug Compartments 64, 65, 83, 90  
 Lugs for Incoming Line Provisions 215  
**M**  
 Manual Shutters 28  
 Master Nameplates 216  
 MCC DeviceNet Terminating Resistor Kit 220  
 Meter Types 59, 60  
 Metric Conversion Table 242  
 Miscellaneous DeviceNet Units 104  
 Miscellaneous Units 99, 105  
 Motor Applications 3  
**N**  
 NEMA  
     Class 2  
     Defined 2  
     Enclosure Type Descriptions 2  
     Type 1 2  
     Type 1 with gasket 2  
     Type 12 2  
     Type 3R 2  
     Type 4 2  
 NEMA/IEC Enclosure Comparison 2

- Network built into MCC Sections 29
- Neutral Bus 25
- Neutral Connection Plate 25
- Neutral Connection Plate Kit 214
- Neutral Connection Plate Unit 105
- NO-OX-ID 214
- O**
- O/L Contact on Left Side of Circuit on Contactors and Starters, Metering, Mains and Feeders, Lighting and Power Panels, and Transformer Units 114
- Options for Combination Soft Starter Controller Units
  - Add Isolation Contactor 141
  - Auxiliary Contacts 143
  - Communication Module 140
  - Control Circuit Ring Lugs 144
  - Control Circuit Spade Lugs 144
  - Control Circuit Wiring 144
  - Control Station Housing 137
  - Control Wire Markers 144
  - DeviceNet Communication Module 140
  - DeviceNet Starter Auxiliary 140
  - Export Packing Below Deck 144
  - French Legend Plates 144
  - Ground Fault Current Transformer 140
  - Grounded Unit Door 142
  - High Interrupting Capacity Fuses 140
  - Human Interface Module (HIM) 140
  - Omit Wiring 142
  - Pilot Lights 138
  - Protective Modules 139
  - Push Buttons 137
  - Selector Switch 137
  - Shunt Trip 144
  - Spanish Legend Plates 144
  - Stainless Steel Nameplate Screws 144
  - Surge Suppressor 142
  - T-Handle 144
  - Unit Door Nameplates 144
  - Unit Ground Stab 142
  - Unit Load Connector 142
  - Unwired Control Relay 142
- Options for Combination Variable Frequency AC Motor Drive Units
  - Analog Output Isolation 190
  - Auxiliary Contacts 193
  - Communication Modules 188
  - Control Circuit Wiring 193
  - Control Wire Markers 193
  - DeviceNet Communication Modules 188
  - Export Packing Below Deck 193
  - French Legend Plates 193
  - Grounded Unit Door 193
  - Human Interface Module (HIM) 189
  - I/O Control Voltage 190
  - Line or Load Reactors 191
  - Pilot Lights 187
  - Push Buttons 187
  - Push Buttons and Selector Switch 187
  - Selector Switch 187
  - Spanish Legend Plates 193
  - Stainless Steel Nameplate Screws 193
  - T-Handle 193
  - Unit Door Nameplates 193
  - Unit Ground Stab 193
  - Unit Load Connector 193
- Options for Contactors and Starters, Metering, Mains and Feeders, Lighting and Power Panels, and Transformer Units
  - 100% Rating of Main Disconnect Switch or Circuit Breaker 122
  - 480V and 600V Power Factor Correction Capacitors 115
  - Additional Unit Space 114
  - Auxiliary Contacts 120
  - Blown Fuse Indicator Lights 115
  - Control Circuit Fuse 114
  - Control Circuit Lugs 122
  - Control Circuit Transformer 110
  - Control Circuit Wiring 122
  - Control Station Housing 107
  - Control Terminal Block 121
  - Control Wire Markers 122, 204
  - Current Sensors 121
  - Current Transducers 121
  - DeviceNet Starter Auxiliary 114
  - E3 Electronic Overload Relay 113
  - Elapsed Time Meter 116
  - Export Packing Below Deck 123
  - External DeviceNet Connector with 120VAC Receptacle 123
  - Filters for Door Vents 114
  - French Legend Plates 123
  - Ground Detection Lights 116
  - Ground Fault Protection 116
  - Grounded Unit Door 116
  - Incoming Neutral Bus 117
  - Incoming Neutral Connection Plate 117
  - Interposing Relay 118
  - Key-interlock Mounting Provision 121
  - O/L Contact on Left Side of Circuit 114
  - Omission of Circuit Breaker 122
  - Omission of Power Terminal Blocks 121
  - Omit Wiring 114
  - Overload Relay Auxiliary Contact (Eutectic Alloy) 114
  - Overload Relay Heater Elements 123
  - Push Buttons 107
  - Push Buttons and Selector Switch 107
  - Selector Switch 107
  - Shunt Trip 122
  - Spanish Legend Plates 123
  - Stainless Steel Nameplate Screws 123
  - Surge Suppressor 114
  - T-Handle 121
  - Thermistor Protection Relay 116
  - Unit Ammeter 116
  - Unit Door Nameplates 123
  - Unit Ground Stab 116
  - Unit Load Connector 116
  - Unwired Control Relay 119
  - Unwired Pull-Apart Terminal Blocks 123

- Unwired Timer Auxiliary 116
- Options for Marshalling Panels and Programmable Controllers
  - Auxiliary Contacts 203
  - ControlLogix Communication Modules 203
  - ControlLogix Processor 203
  - ControlLogix Programming Cable 203
  - ControlNet T-Tap 203
  - DeviceNet Scanner Module 203
  - Export Packing Below Deck 204
  - Grounded Unit Door 203
  - Light and Door Switch 204
  - Omit Horizontal Power Bus 204
  - Power Supply 203
  - Stainless Steel Nameplate Screws 204
  - Terminal Blocks 204
  - T-Handle 204
  - Unit Door Nameplates 204
  - Unit Ground Stab 203
- Options for SC-I and PE-I Sections
  - Auxiliary Contacts 23
  - Export Packing Below Deck for Sections 23
  - Grounded Unit Door 23
  - Shunt Trip 23
  - T-Handle 23
- Options for Space Saving NEMA Starter Units
  - Additional Unit Space 127
  - Auxiliary Contacts 128
  - Control Circuit Fuse 127
  - Control Circuit Transformer 126
  - Control Wire Markers 128
  - DeviceNet Starter Auxiliary 126
  - E1 Plus Electronic Overload Relay 126
  - E3 Electronic Overload Relay 126
  - Elapsed Time Meter 127
  - Export Packing Below Deck 128
  - French Legend Plates 128
  - Grounded Unit Door 127
  - Omit Wiring 127
  - Pilot Lights 125
  - Push Buttons 125
  - Push Buttons and Selector Switch 125
  - Selector Switch 125
  - Spanish Legend Plates 128
  - Stainless Steel Nameplate Screws 128
  - Surge Suppressor 127
  - T-Handles 128
  - Unit Door Nameplate 128
  - Unit Ground Stab 127
  - Unit Load Connector 127
  - Unwired Control Relay 127
- Outgoing Lug Compartments 63
- Overload Relay Auxiliary Contact (Eutectic Alloy) on Contactors and Starters, Metering, Mains and Feeders, Lighting and Power Panels, and Transformer Units 114
- Overload Relay Class Designations 227
- Overload Relay Heater Elements on Contactors and Starters, Metering, Mains and Feeders, Lighting and Power Panels, and Transformer Units 123
- P**
- Parts Illustrations
  - Typical 15" Deep Section Construction 11
- Pilot Lights on Combination Soft Starter Controller Units 138
- Pilot Lights on Combination Variable Frequency AC Motor Drive Units 187
- Pilot Lights on Contactors and Starters, Metering, Mains and Feeders, Lighting and Power Panels, and Transformer Units 125
- Plug-In Unit Retrofit Kit 217
- Power Factor Correction Capacitors on Contactors and Starters, Metering, Mains and Feeders, Lighting and Power Panels, and Transformer Units 115
- Power Supply on Marshalling Panels and Programmable Controllers 203
- Power System 247
- Power Terminal Blocks on Contactors and Starters, Metering, Mains and Feeders, Lighting and Power Panels, and Transformer Units 121
- Primary Voltage Code for Bulletins 2195, 2196, and 2197 205
- Protective Caps 28
- Protective Modules on Combination Soft Starter Controller Units 139
- Publication Overview 1
- Pull-Apart Terminal Blocks 217
- Pullbox 213
- Push Buttons and Selector Switch on Contactors and Starters, Metering, Mains and Feeders, Lighting and Power Panels, and Transformer Units 107
- Push Buttons on Combination Soft Starter Controller Units 137
- Push Buttons on Combination Variable Frequency AC Motor Drive Units 187
- Push Buttons on Contactors and Starters, Metering, Mains and Feeders, Lighting and Power Panels, and Transformer Units 107
- R**
- Round DeviceNet Cable with Connectors 220
- S**
- Section Modification
  - SC and PE-I 23
  - SC-II and PE-II 24, 25, 26, 27, 28
- Seismic Applications 3, 246
- Selector Switch on Combination Soft Starter Controller Units 137
- Selector Switch on Combination Variable Frequency AC Motor Drive Units 187
- Selector Switch on Contactors and Starters, Metering, Mains and Feeders, Lighting and Power Panels, and Transformer Units 107
- Serial Number Information 5
- Series Letter Information 5
- Service and Storage Conditions, 3
- Short Circuit Withstand Ratings for Combination Circuit Breaker Units 236
- Short Circuit Withstand Ratings for Combination Fusible Disconnect Units 235
- Short Circuit Withstand Ratings for Combination Soft Starter Controller Units (SMCs) 237
- Short Circuit Withstand Ratings for Combination Variable Frequency AC Motor Drive Units 238

- Short Circuit Withstand Ratings for Programmable Controllers 238
- Shunt Trip on Combination Soft Starter Controller Units 144
- Shunt Trip on Contactors and Starters, Metering, Mains and Feeders, Lighting and Power Panels, and Transformer Units 122
- Shunt Trip on SC-I and PE-I 23
- Shutters 28
- Smoke Detector Unit 105
- Soft Starter Controller (SMC) Units 129
- Software, IntelliCENTER 30
- Space Heater Factory Installed in MCC 28
- Space Heater Kit 213
- Space Saving NEMA Bulletin 2106 and 2107, Full Voltage Reversing Starters (FVR) 40
- Space Saving NEMA Bulletin 2112 and 2113, Full Voltage Non-Reversing Starters (FVNR) 46
- Stainless Steel Nameplate Screws 216
- Stainless Steel Nameplate Screws on Combination Soft Starter Controller Units 144
- Stainless Steel Nameplate Screws on Combination Variable Frequency AC Motor Drive Units 193
- Stainless Steel Nameplate Screws on Contactors and Starters, Metering, Mains and Feeders, Lighting and Power Panels, and Transformer Units 123
- Stainless Steel Nameplate Screws on Marshalling Panels and Programmable Controllers 204
- Storage Conditions 1
- Suffix Letter Designation  
Circuit Breaker 9
- Surge Protective Device Unit 105
- Surge Suppressor on Combination Soft Starter Controller Units 142
- Surge Suppressor on Contactors and Starters, Metering, Mains and Feeders, Lighting and Power Panels, and Transformer Units 114
- T**
- Terminal Blocks on Marshalling Panels and Programmable Controllers 204
- T-Handle 28
- T-Handle on Combination Soft Starter Controller Units 144
- T-Handle on Combination Variable Frequency AC Motor Drive Units 193
- T-Handle on Contactors and Starters, Metering, Mains and Feeders, Lighting and Power Panels, and Transformer Units 121
- T-Handle on Marshalling Panels and Programmable Controllers 204
- T-Handle on SC-I and PE-I 23
- Thermistor Protection Relay on Contactors and Starters, Metering, Mains and Feeders, Lighting and Power Panels, and Transformer Units 116
- Top Horizontal Wireway Pan 213
- Touch-Up Paint 214
- Trip Current for Bulletin 2103L 209
- Type 2 Protection 3
- U**
- UL/cUL/CSA Marking 1
- Unit Ammeter on Contactors and Starters, Metering, Mains and Feeders, Lighting and Power Panels, and Transformer Units 116
- Unit Door Grounding Kit 217
- Unit Door Nameplates 216
- Unit Door Nameplates on Combination Soft Starter Controller Units 144
- Unit Door Nameplates on Combination Variable Frequency AC Motor Drive Units 193
- Unit Door Nameplates on Contactors and Starters, Metering, Mains and Feeders, Lighting and Power Panels, and Transformer Units 123
- Unit Door Nameplates on Marshalling Panels and Programmable Controllers 204
- Unit Ground Stab on Combination Soft Starter Controller Units 142
- Unit Ground Stab on Combination Variable Frequency AC Motor Drive Units 193
- Unit Ground Stab on Contactors and Starters, Metering, Mains and Feeders, Lighting and Power Panels, and Transformer Units 116
- Unit Ground Stab on Marshalling Panels and Programmable Controllers 203
- Unit Insert Extension Kit 217
- Unit Insert, Empty 102
- Unit Isolating Barriers 28, 214
- Unit Load Connector on Combination Soft Starter Controller Units 142
- Unit Load Connector on Combination Variable Frequency AC Motor Drive Units 193
- Unit Load Connector on Contactors and Starters, Metering, Mains and Feeders, Lighting and Power Panels, and Transformer Units 116
- Unit Operating Handle Extender 213
- Unit Support Pan 216
- Units and Sections  
Series Lettering 8
- Unwired Control Relay on Combination Soft Starter Controller Units 142
- Unwired Control Relay on Contactors and Starters, Metering, Mains and Feeders, Lighting and Power Panels, and Transformer Units 119
- Unwired Pull-Apart Terminal Blocks on Contactors and Starters, Metering, Mains and Feeders, Lighting and Power Panels, and Transformer Units 123
- Unwired Timer Auxiliary on Contactors and Starters, Metering, Mains and Feeders, Lighting and Power Panels, and Transformer Units 116
- V**
- Vertical Ground Bus 26
- Vertical Ground Bus Kit 214
- Vertical Section Catalog Numbers  
Configuring 23
- Vertical Sections 11  
Catalog Number Explanations 12
- Vertical Unit Load Ground Bus 26
- Vertical Unit Load Ground Bus Kit 214
- Vertical Wireway Tie Bar 214
- W**
- Weights of CENTERLINE Motor Control Center Sections 226
- Wire Markers, Control 122, 204
- Wiring Class 2
- Wiring Diagram Holder Kit 214
- Wiring on Combination Soft Starter Controller Units 142
- Wiring on Contactors and Starters, Metering, Mains and Feeders, Lighting and Power Panels, and Transformer Units 114
- Wiring Type 2







CENTERLINE®, CenterONE®, ControlLogix®, DeviceLogix™, IntelliCENTER®, PowerFlex®, Product Selection Toolbox™, Rockwell Automation®, RSView®, SMC™, SMC™ 3, SMC™ Dialog Plus, SMC™ Flex, Powermonitor™, ArcShield™, Allen-Bradley® are trademarks of Rockwell Automation, Inc.

Trademarks not belonging to Rockwell Automation are property of their respective companies.

**[www.rockwellautomation.com](http://www.rockwellautomation.com)**

---

#### **Power, Control and Information Solutions Headquarters**

Americas: Rockwell Automation, 1201 South Second Street, Milwaukee, WI 53204-2496 USA, Tel: (1) 414.382.2000, Fax: (1) 414.382.4444

Europe/Middle East/Africa: Rockwell Automation, Vorstlaan/Boulevard du Souverain 36, 1170 Brussels, Belgium, Tel: (32) 2 663 0600, Fax: (32) 2 663 0640

Asia Pacific: Rockwell Automation, Level 14, Core F, Cyberport 3, 100 Cyberport Road, Hong Kong, Tel: (852) 2887 4788, Fax: (852) 2508 1846