

THREE PHASE WIRING FOR ASCO® SERIES 300 AUTOMATIC TRANSFER SWITCHES RATED 1000-3200 AMPERES WITH GROUP 1 CONTROLS

CONTROL FEATURES

VOLTAGE AND FREQUENCY SENSING

- A. DIFFERENTIAL TYPE VOLTAGE SENSING ON ALL PHASES OF NORMAL SOURCE. DROPOUT SETTING SELECTABLE AT 90, 85, 80 OR 70% OF NOMINAL. FACTORY SET AT 85%. PICKUP VOLTAGE ADJUSTABLE AT 90 OR 95% OF NOMINAL. (DEFAULT IS 95% IF DROPOUT IS SET TO 90%). FACTORY SET AT 90%. (REFER TO THE OPERATOR'S MANUAL FURNISHED WITH EACH TRANSFER SWITCH REGARDING CONTROL PANEL SETTINGS).
- B. SINGLE PHASE VOLTAGE SENSING OF EMERGENCY SOURCE. NON-ADJUSTABLE DROPOUT SETTING AT 75% OF NOMINAL. NON-ADJUSTABLE PICKUP SETTING AT 90% OF NOMINAL.
- C. FREQUENCY SENSING OF EMERGENCY SOURCE. NON-ADJUSTABLE DROPOUT SETTING AT 85% OF NOMINAL. NON-ADJUSTABLE PICKUP SETTING AT 95% OF NOMINAL.

TIME DELAYS

- A. MOMENTARY NORMAL SOURCE OUTAGE DELAY - ACTIVATED WHEN THE NORMAL SOURCE FAILS. DEACTIVATED WHEN THE NORMAL SOURCE IS ACCEPTABLE. PROVIDES A SELECTABLE (1 OR 3 SECOND) DELAY ON TRANSFER AND ENGINE STARTING SIGNALS. FACTORY SET AT 3 SECONDS. (REFER TO THE OPERATOR'S MANUAL FURNISHED WITH EACH TRANSFER SWITCH REGARDING CONTROL PANEL SETTINGS).
- B. TRANSFER TO EMERGENCY DELAY - ACTIVATED AFTER THE MOMENTARY NORMAL SOURCE OUTAGE DELAY EXPIRES AND THE EMERGENCY SOURCE IS SENSED TO BE ACCEPTABLE. TRANSFER TO EMERGENCY IS COMMITTED TO ON INITIATION OF DELAY. DEACTIVATED WHEN THE EMERGENCY SOURCE IS UNACCEPTABLE. PROVIDES AN ADJUSTABLE DELAY FROM 0 TO 5 MINUTES. FACTORY SET AT 0 MINUTES. (REFER TO OPERATOR'S MANUAL FURNISHED WITH EACH TRANSFER SWITCH REGARDING CONTROL PANEL SETTINGS).
- C. RETRANSFER TO NORMAL DELAY - ACTIVATED WHEN THE NORMAL SOURCE IS ACCEPTABLE. DEACTIVATED WHEN THE NORMAL SOURCE FAILS WITH NO TRANSFER TO NORMAL. ALSO DEACTIVATED WHEN THE EMERGENCY SOURCE FAILS WHILE THE NORMAL SOURCE IS ACCEPTABLE WITH TRANSFER TO NORMAL. ADJUSTABLE DELAY FROM 1 SECOND TO 30 MINUTES. FACTORY SET TO 30 MINUTES. (REFER TO THE OPERATOR'S MANUAL FURNISHED WITH EACH TRANSFER SWITCH REGARDING CONTROL PANEL SETTINGS).
- D. UNLOADED RUNNING (ENGINE COOL DOWN) DELAY - ACTIVATED ON EXPIRATION OF RETRANSFER TO NORMAL DELAY OR FOLLOWING EXPIRATION OF THE NORMAL SOURCE OUTAGE DELAY WITHOUT A COMMIT TO TRANSFER TO EMERGENCY. NON-ADJUSTABLE DELAY OF 5 MINUTES.
- E. MOMENTARY EMERGENCY SOURCE OUTAGE DELAY - ACTIVATED WHEN THE SWITCH IS IN THE EMERGENCY POSITION AND THE EMERGENCY SOURCE FAILS. FACTORY SET AT 4 SECONDS. RESET IF EMERGENCY RESTORES WITHIN 4 SECONDS.

ENGINE CONTROL CONTACTS

ONE SET OF FORM C CONTACTS (1 N/O & 1 N/C) THAT CHANGE POSITION ON EXPIRATION OF THE NORMAL SOURCE OUTAGE DELAY AND RESET ON EXPIRATION OF THE UNLOADED RUNNING (ENGINE COOL DOWN) DELAY. OUTPUT CONTACTS (NR) ARE RATED 5 AMPS RESISTIVE AT 28V DC OR 120V AC MAXIMUM.

OPERATOR INTERFACE INDICATORS & CONTROLS MEMBRANE TYPE

- A. TRANSFER SWITCH TEST - MOMENTARY PUSH-BUTTON TO SIMULATE NORMAL SOURCE FAILURE SEQUENCE OF OPERATION. PRESS AND HOLD FOR AT LEAST 15 SECONDS TO ALLOW TIME FOR ENGINE-GENERATOR SET TO START.
- B. BYPASS TIME DELAY - MOMENTARY PUSH-BUTTON TO BYPASS EITHER THE TRANSFER TO EMERGENCY DELAY, ENGINE EXERCISER PERIOD OR THE RETRANSFER TO NORMAL DELAY DEPENDING ON WHICH DELAY IS ACTIVE AT THE TIME THE PUSH-BUTTON IS ACTIVATED.
- C. SET ENGINE EXERCISER - MOMENTARY PUSH-BUTTON TO ACTIVATE A SEVEN (7) DAY TIMER FOR AUTOMATIC WEEKLY TESTING OF THE ENGINE GENERATOR SET EITHER WITH OR WITHOUT LOAD TRANSFER. THE TIMER IS POWERED BY A NON-RECHARGEABLE 9V BATTERY WHEN NORMAL AND EMERGENCY SOURCES ARE UNAVAILABLE. DEPRESSING THE MOMENTARY PUSH-BUTTON FOR 5 SECONDS SETS THE TIME OF WEEK AT WHICH TESTING IS TO OCCUR. THE FEATURE IS ACTIVATED BY SETTING A DIP SELECTOR SWITCH ON THE CONTROL PANEL. ENGINE START WITH OR WITHOUT LOAD TRANSFER IS SELECTED WITH A SECOND DIP SELECTOR SWITCH ON THE CONTROL PANEL. FACTORY SET TO DISABLED, NO LOAD. (REFER TO THE OPERATOR'S MANUAL FURNISHED WITH EACH TRANSFER SWITCH REGARDING CONTROL PANEL SETTINGS).
- D. LOAD CONNECTED TO INDICATORS GREEN LED INDICATOR TO INDICATE WHEN THE TRANSFER SWITCH LOAD IS CONNECTED TO THE NORMAL SOURCE. RED LED INDICATOR TO INDICATE WHEN THE TRANSFER SWITCH IS CONNECTED TO THE EMERGENCY SOURCE.
- E. SOURCE AVAILABLE INDICATORS GREEN LED INDICATOR TO INDICATE WHEN THE NORMAL SOURCE IS AVAILABLE. RED LED INDICATOR TO INDICATE WHEN THE EMERGENCY SOURCE IS AVAILABLE.

LOAD DISCONNECT FEATURE

ONE SET OF FORM C CONTACTS (1 N/O & 1 N/C) THAT CHANGE POSITION ON ACTIVATION OF A SELECTABLE TIME DELAY BEFORE TRANSFER (LD TDBT) AND RESET EITHER IMMEDIATELY FOLLOWING TRANSFER OR FOR THE SAME DELAY AS SET FOR PRE-SIGNAL BEFORE TRANSFER. SELECTABLE AS 0, 3, 10 OR 20 SECONDS. FACTORY SET AT 0. (REFER TO THE OPERATOR'S MANUAL FURNISHED WITH EACH TRANSFER SWITCH REGARDING CONTROL PANEL SETTINGS). OUTPUT CONTACTS (OP) ARE RATED 5 AMPS RESISTIVE AT 28 VDC OR 120 VAC MAXIMUM.

MOTOR LOAD TRANSFER FEATURE

INPHASE TRANSFER CONTROL LOGIC TO INITIATE AN INPHASE TRANSFER OF MOTOR LOADS BETWEEN LIVE SOURCES. USED TO HELP PREVENT NOISANCE TRIPPING OF DISTRIBUTION CIRCUIT BREAKERS AND POSSIBLE DAMAGE TO MECHANICAL LOADS ASSOCIATED WITH OUT OF PHASE TRANSFER. ACTIVATED BY SETTING A DIP SWITCH ON THE CONTROL PANEL. FACTORY SET AS DISABLED. (REFER TO OPERATOR'S MANUAL FURNISHED WITH EACH TRANSFER SWITCH REGARDING CONTROL PANEL SETTINGS).

REMOTE CONTROL FEATURES

THE FOLLOWING CONTROL PANEL INPUTS PROVIDE REMOTE CONTROL FUNCTIONS FOR THE AUTOMATIC TRANSFER SWITCH. EACH CONTROL FUNCTION CAN BE IMPLEMENTED BY THE CUSTOMER PROVIDING THE FORM OF CONTROL CONTACT DESCRIBED. EACH CONTROL CONTACT MUST BE SUITABLE FOR A 5 VDC LOW ENERGY CIRCUIT. EACH CONTROL FEATURE IS ACTIVATED BY SETTING A DIP TYPE SELECTOR SWITCH ON THE CONTROL PANEL. (REFER TO THE OPERATOR'S MANUAL FURNISHED WITH EACH TRANSFER SWITCH REGARDING CONTROL PANEL SETTINGS).

- A. REMOTE TEST FEATURE - REQUIRES A CUSTOMER SUPPLIED, REMOTE, NORMALLY CLOSED CONTACT. OPENING OF THE CONTACT SIMULATES A FAILURE OF THE NORMAL SOURCE SIMILAR TO THE SEQUENCE OUTLINED FOR THE TRANSFER SWITCH TEST PUSH-BUTTON. THE TRANSFER SWITCH WILL REMAIN CONNECTED TO THE EMERGENCY SOURCE UNDER ALL CONDITIONS WHILE THE CONTACT IS OPEN.
- B. REMOTE TRANSFER TO EMERGENCY FEATURE - REQUIRES A CUSTOMER SUPPLIED, REMOTE, NORMALLY CLOSED CONTACT. OPENING OF THE CONTACT CAUSES ENGINE START AND TRANSFER TO THE EMERGENCY SOURCE. RECLOSURE OF THE CONTACT ACTIVATES THE RETRANSFER TO NORMAL DELAY PRIOR TO RETRANSFER. IN THE EVENT THAT THE EMERGENCY SOURCE FAILS WHILE THE TRANSFER SWITCH IS CONNECTED TO EMERGENCY AND THE REMOTE CONTACT IS OPEN, THE TRANSFER SWITCH WILL AUTOMATICALLY RETRANSFER TO THE NORMAL SOURCE.
- C. INHIBIT TRANSFER TO EMERGENCY FEATURE - REQUIRES A CUSTOMER SUPPLIED, REMOTE, NORMALLY CLOSED CONTACT. OPENING OF THE CONTACT WILL PROHIBIT THE TRANSFER SWITCH FROM TRANSFERRING TO THE EMERGENCY SOURCE WHILE CONNECTED TO THE NORMAL SOURCE.
- D. BYPASS TRANSFER TIME DELAY FEATURE - REQUIRES A CUSTOMER SUPPLIED, REMOTE, NORMALLY CLOSED CONTACT. OPENING OF THE CONTACT BYPASSES THE RETRANSFER TO NORMAL DELAY IF ACTIVE.

GENERAL NOTES

1. SWITCH SHOWN DE-ENERGIZED CONNECTED TO NORMAL SOURCE. DEVICE SYMBOLS AND DESIGNATIONS ARE IN ACCORDANCE WITH NEMA PUB. ICS 1-1983, PART 1-101A.
2. ALL WIRING IS #16 AWG, TINNED, STRANDED COPPER UNLESS OTHERWISE INDICATED.
3. ○ INDICATES CUSTOMER CONNECTION POINTS.
4. ● INDICATES FACTORY CONNECTION POINTS.
5. CONNECTION POINTS THAT HAVE BOTH CUSTOMER CONNECTIONS AND FACTORY CONNECTIONS ARE SHOWN OPEN AS CUSTOMER CONNECTION POINTS.
6. THE TRANSFER UNIT IS MOUNTED ON THE BACK INSIDE SURFACE OF THE ENCLOSURE. THE CONTROL PANEL AND ANY OPTIONAL ACCESSORIES ARE MOUNTED ON THE INSIDE SURFACE OF THE DOOR.
7. AN OPERATOR'S MANUAL IS FURNISHED WITH EACH AUTOMATIC TRANSFER SWITCH. REFER TO THIS PUBLICATION PRIOR TO INSTALLATION AND OPERATION OF THE SWITCH.
8. GROUND STRAP ON CONTROL PANEL IS AFFIXED TO CHASSIS (ENCLOSURE) AT LOWER LEFT CONTROL PANEL MOUNTING STUD.

OPTIONAL ACCESSORIES

ACCESSORY 11BG - PROGRAMMABLE ENGINE EXERCISER & SOURCE AVAILABILITY SIGNAL MODULES

PROGRAMMABLE ENGINE EXERCISER: A PROGRAMMABLE SEVEN (7) DAY OR FOURTEEN (14) DAY ELECTRONIC TIME SWITCH FOR AUTOMATIC WEEKLY TESTING OF THE ENGINE GENERATOR SET EITHER WITH OR WITHOUT LOAD. EACH DAY OF THE WEEK IS INDIVIDUALLY PROGRAMMABLE. THE TIME OF DAY IS PRESERVED BY A BATTERY BUILT INTO THE GROUP 1 TRANSFER SWITCH CONTROL PANEL.

THE FEATURE IS ACTIVATED BY SETTING A DIP SELECTOR SWITCH ON THE CONTROL PANEL. ENGINE START WITH OR WITHOUT LOAD TRANSFER IS SELECTED WITH A SECOND DIP SELECTOR SWITCH ON THE CONTROL PANEL. (REFER TO THE OPERATOR'S MANUAL FURNISHED WITH EACH TRANSFER SWITCH REGARDING CONTROL PANEL AND TIMER SETTINGS).

SOURCE AVAILABILITY SIGNALING: ONE FORM C CONTACT EACH FOR THE NORMAL & EMERGENCY SOURCES SIGNAL THE ACCEPTABILITY OF THE SOURCE AS SENSED BY THE GROUP 1 CONTROL PANEL. THE SIGNAL CONTACTS OPERATE IN CONJUNCTION WITH THE SOURCE AVAILABILITY LED STATUS INDICATION PROVIDED ON THE OPERATOR INTERFACE. FIELD WIRING TERMINALS ARE PROVIDED AS SHOWN, LOCATED ON THE INSIDE DOOR BEHIND THE OPERATOR INTERFACE. CONTACTS RATED 2 AMPS @ 30VDC, 0.5 AMPS @ 125 VAC (RESISTIVE).

SERIAL COMMUNICATIONS INTERFACE (ACCESSORY 72A)

RS-485 SERIAL INTERFACE TO CONTROL PANEL. FOR REMOTE MONITORING AND CONTROL FROM ASCO COMMUNICATIONS BASED PRODUCTS.

- ACC. 14AA (2) AUXILIARY CONTACT CLOSED ON NORMAL.
- ACC. 14BA (2) AUXILIARY CONTACT CLOSED ON EMERGENCY.
- ACC. 44A STRIP HEATER, THERMOSTAT & TB. CUSTOMER POWER SUPPLY 120VAC.
- ACC. 44G STRIP HEATER, THERMOSTAT & TRANSFORMER. POWER SUPPLY FROM LOAD TERMINALS OF TRANSFER SWITCH.

FIELD CONNECTIONS

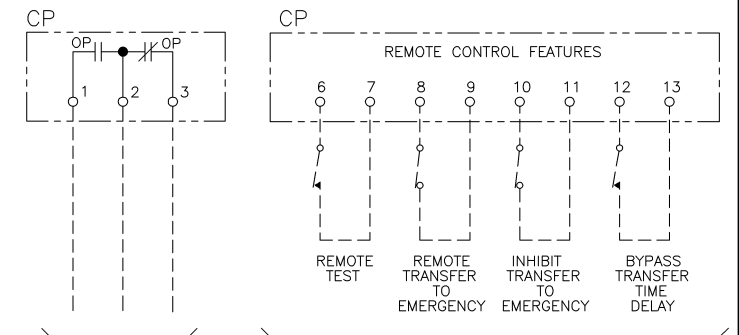
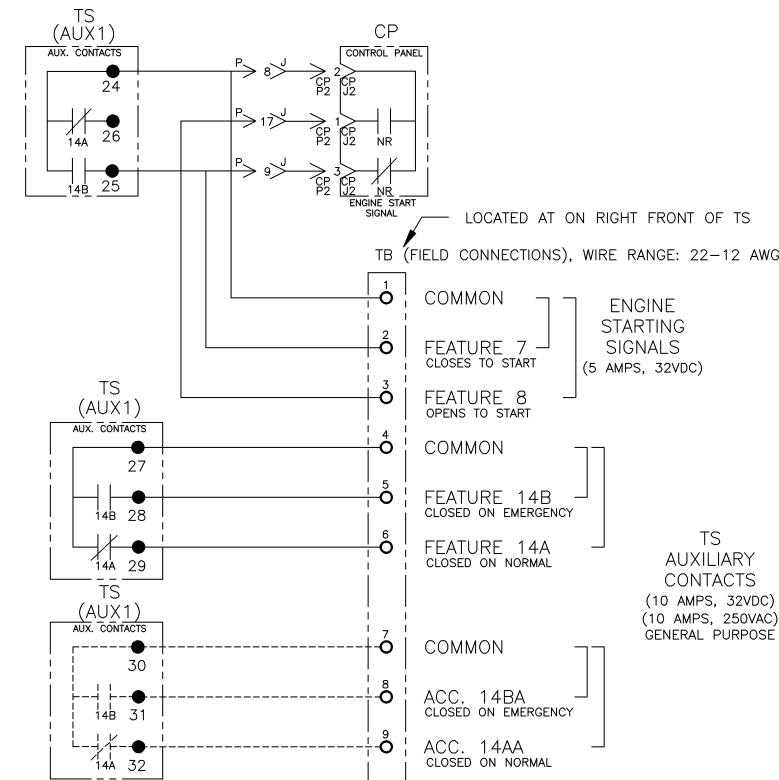

TS AUXILIARY CONTACTS (10 AMPS, 32VDC) (10 AMPS, 250VAC) GENERAL PURPOSE

ACC. 11BG SOURCE AVAILABILITY SIGNALS

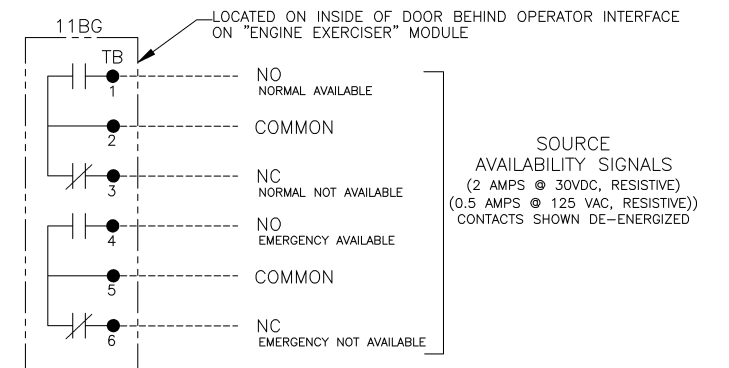

ACC. 72A SERIAL COMMUNICATIONS OPTION COMMUNICATING WITH GROUP 1 CONTROL PANEL (CP)

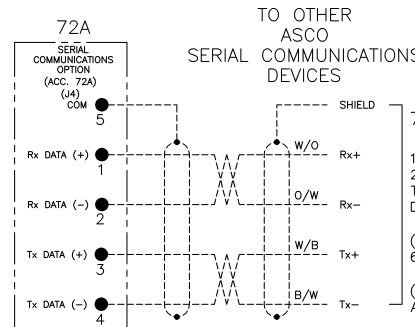

72A NOTES:

1. EARTH GROUND SHIELD AT HOST DEVICE ONLY.
2. FIELD WIRING: USE UL LISTED, STRANDED, TWISTED PAIRS, OVERALL FOIL SHIELD WITH STRANDED DRAIN WIRE SUITABLE FOR RS-422 EQUIVALENT TO: (STANDARD 80°C) BELDEN 9842 OR 9829 OR ALPHA 6202C OR 6222C (PLENUM RATED) BELDEN 89729 OR 82729 OR ALPHA 58902

TS FRAME	BASE CATALOG NUMBER			CATALOG NUMBER SUFFIXES			EXPLANATION OF CATALOG NUMBER CODES										
	TYPE	NEUTRAL TYPE	PHASE POLES	AMPS	VOLT CODE	CONTROLLER	OPTIONAL ACCESSORY	ENCLOSURE CODE	NEUTRAL TYPE					ENCLOSURE CODES			
									CODE	DESCRIPTION	VOLTAGE CODES 3 PHASE (3 OR 4 WIRE) 50 OR 60 Hz	NOMINAL VOLTAGE	CODE	TYPE	DESCRIPTION		
G	300	B	3	1000 1200 1600 2000 2600 3000 3200	C D E F H J K L M N Q R	1	X	C F G L	BLANK B C	SOLID SWITCHING OVERLAPPING	C D E F H J K L M N Q R	208 220 230 240 380 400 415 440 460 480 575 600	BLANK C F G L	1 3R 4 12	OPEN TYPE (NO ENCLOSURE) GENERAL PURPOSE, INDOOR OUTDOOR, RAINPROOF, SLEET & ICE RESISTANT INDOOR/OUTDOOR, WATERTIGHT & DUSTTIGHT INDOOR, INDUSTRIAL ENVIRONMENTS, OILTIGHT & DUSTTIGHT		

CATALOG NUMBER _____
ASCO CERTIFIED TO S.O. _____
 BY _____
 DATE _____
 FORM REV M
 PROJECT NAME: _____
 WIRING _____ DIAGRAM _____
 SERIES G300 ATS 3PH 1000-3200 AMPS
 "G" FRAME, GROUP 1 CONTROLS
 DRAWN BY: DJB 12/10/01
 CHECKED: BK 12/10/01
 PROJECT APPROVAL: WK 12/10/01
 FINAL APPROVAL: _____
 MANUFACTURING TOLERANCES TO BE IN ACCORDANCE WITH ASCO PROCEDURE MP-1-003. FOR PLASTIC PARTS SEE MP-1-005. ASSEM. REF. NO. _____
 PROPERTY OF ASCO POWER TECHNOLOGIES. USE PERMITTED FOR OUR WORK ONLY. ALL RIGHTS OF DESIGN OR INVENTION ARE RESERVED.
 ASCO POWER TECHNOLOGIES, L.P.
 FLORHAM PARK, NEW JERSEY 07932 U.S.A.
 SCALE: NONE SIZE: DS
 DWG. NO. 733503
 DRAWING M ECH. NO. 235174 SHEET 1 OF 4

M	235174	TR	WK	1/3/12
L	234078	BK	BK	10/07/11
K	233030	AE	BK	07/25/11
J	213459	WK	BK	05/21/07
H	167603	BK	BK	07/22/04
G	167217	SDH	SDH	06/04/04
F	165833	BWM	WK	01/05/04
E	164762	BWM	WK	9/03
D	162323	BWM	WK	12/9/02
C	162093	BK	BK	12/03/02
B	162198	BWM	BK	11/13/02
A	161983	BWM	WK	10/28/02
-	159489	BWM	WK	12/10/01

MAIN POWER POLES

TS OPERATOR CIRCUIT

EMERGENCY

NORMAL

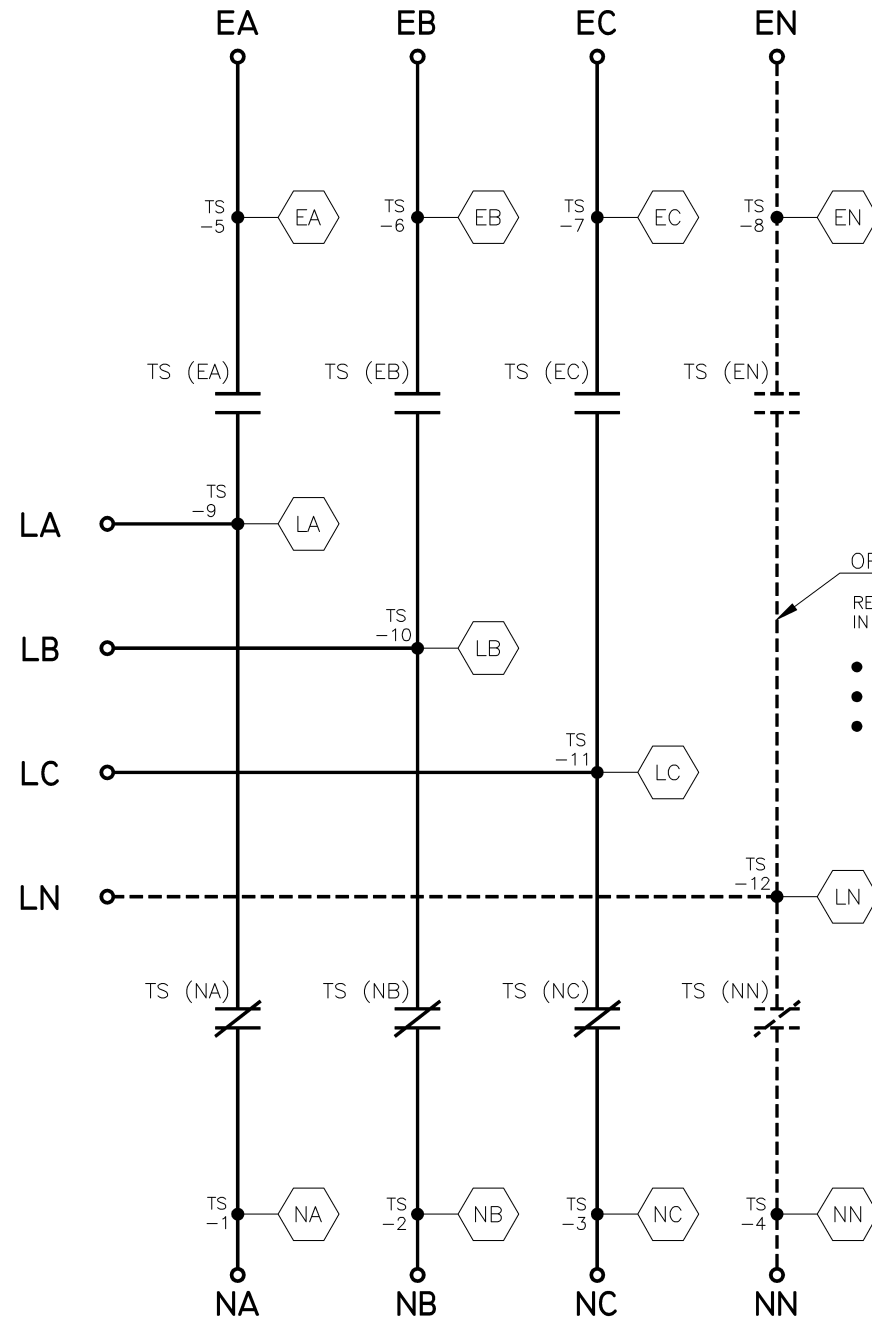

OPTIONAL NEUTRAL TYPES
 REFER TO "EXPLANATION OF CATALOG NUMBER CODES"
 IN CATALOG NUMBER CHART ON SHEET 1.

- SWITCHING CONTACTS
- OVERLAPPING CONTACTS
- SOLID BUS PLATE

NORMAL

EMERGENCY

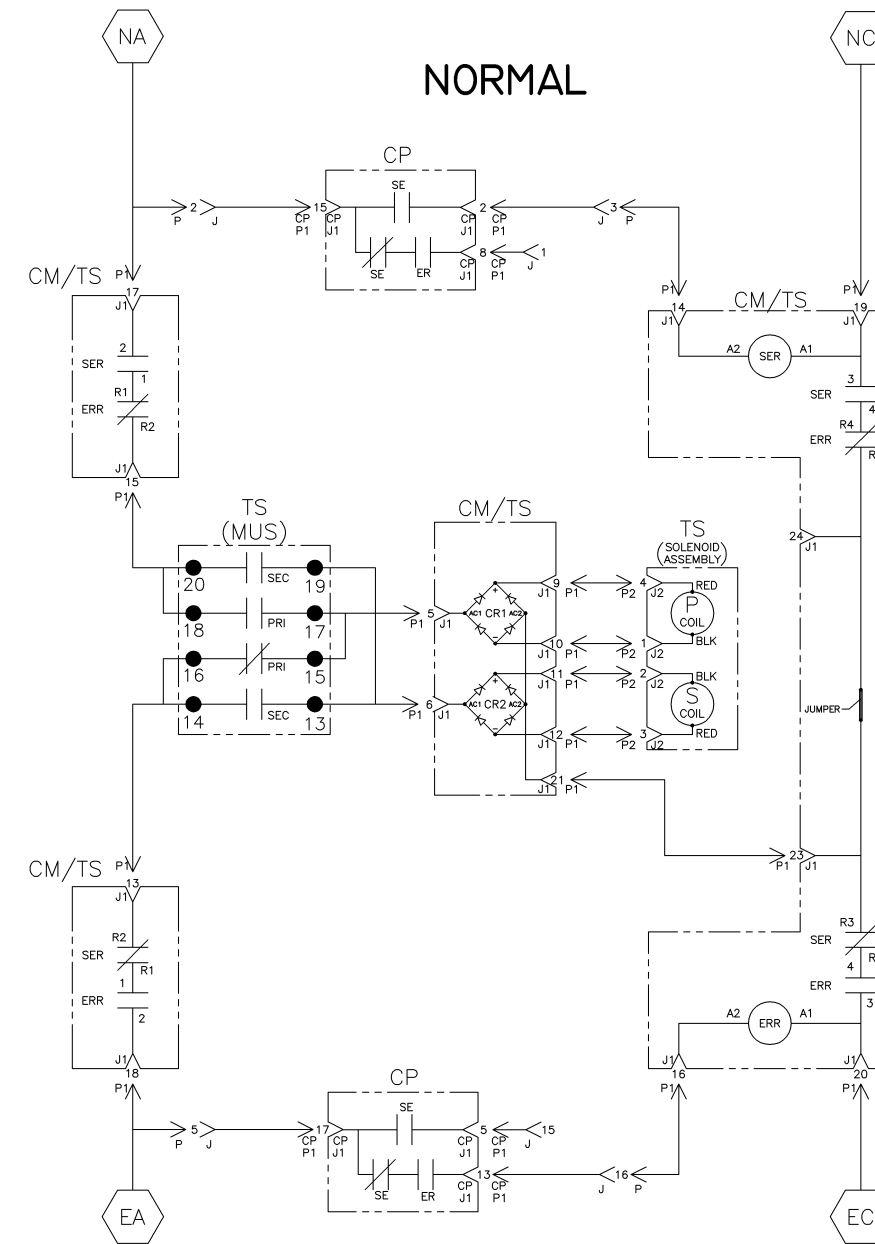

NOTE:
 ATS SHOWN CLOSED ON NORMAL SOURCE.

TS (MUS) CONTACTS		SOLENOID POSITION			
MUS		NORM	AFTER TDC	EMER	
13-14	>				
15-16	>				
17-18	>				
19-20	>				

* AFTER SOLENOID PASSES THROUGH TOP DEAD CENTER POSITION.

PROJECT NAME: WIRING DIAGRAM

SERIES G300 ATS 3PH 1000-3200 AMPS
 "G" FRAME, GROUP 1 CONTROLS

BY	DATE	MANUFACTURING TOLERANCES TO BE IN ACCORDANCE WITH ASCO PROCEDURE MP-1-003. FOR PLASTIC PARTS SEE MP-1-005.	ASSEM. REF. NO.	COMPUTER GENERATED DRAWING
DRAWN BY	DJB	12/10/01		SCALE NONE SIZE DS
CHECKED	BK	12/10/01		DWG. NO. 733503
PROJECT APPROVAL	WK	12/10/01		DRAWING M ECN NO. 235174 SHEET 2 OF 4
FINAL APPROVAL				

ASCO POWER TECHNOLOGIES, L.P.
 FLORHAM PARK, NEW JERSEY 07932 U.S.A.

WIRE RUN LISTING

CONTROL SIGNALS & INDICATION

NORMAL SOURCE CIRCUITS

WIRE No.	605454 (P,P1,P2,J3) MAIN TS	CLR	AWG
1	P-2,TS-1		16
2	P-3,P1-14		
3	P-4,TS-3		
4	P-5,TS-5		
5	P-6,TS-7		
4	P-7,TS-5		
6	P-8,TS(AUX1)-24		
6	TS(AUX1)-24,J3-1		
7	P-9,TS(AUX1)-25		
7	TS(AUX1)-25,J3-2		
8	P-10,TS(AUX1)-21		
9	P-11,TS-2		
10	P-12,TS-1		
11	P-13,TS(AUX1)-22		
12	P-14,TS(AUX1)-23		
13	P-16,P1-16		
14	P-17,J3-3		
15	P-18,TS-6		
16	P-19,TS-9		
17	P-20,TS-10		
18	P-21,TS-11		
19	P-22,TS-4		
20	P-23,TS-8		
21	P-24,TS-12		
22	P1-5,TS(MUS)-17		
22	TS(MUS)-17,TS(MUS)-15		
23	P1-6,TS(MUS)-19		
23	TS(MUS)-19,TS(MUS)-13		
24	P1-9,P2-4		
25	P1-10,P2-1		
26	P1-11,P2-2		
27	P1-12,P2-3		
28	P1-13,TS(MUS)-16		
28	TS(MUS)-16,TS(MUS)-14		
29	P1-15,TS(MUS)-20		
29	TS(MUS)-20,TS(MUS)-18		
1	P1-17,TS-1		
4	P1-18,TS-5		
3	P1-19,TS-3		
5	P1-20,TS-7		
30	P1-21,P1-23		
REMOVE WIRES			
6	TS(AUX1)-24,J3-1		
7	TS(AUX1)-25,J3-2		
14	P-17,J3-3		
ADD WIRES			
200	P-1		
222	P-15		
201	P1-1		
202	P1-2		
203	P1-3		
204	P1-4		
205	P1-7		
206	P1-8		
207	P1-16		
208	P1-22		
209	P1-24		

WIRE No.	ADDITIONAL WIRE CONNECTIONS	CLR	AWG
31	TS(AUX1)-27,TB-4		16
32	TS(AUX1)-28,TB-5		
33	TS(AUX1)-29,TB-6		
6	TS(AUX1)-24,TB-1		
7	TS(AUX1)-25,TB-2		
14	P-17,TB-3		

WIRE No.	HARNESS LOCATOR HARNESS 483763 (J, P1, P2) TS-CP HARNESS	CLR	AWG
1	J-1,P1-8		16
2	J-2,P1-15		
3	J-3,P1-2		
4	J-4,P1-4		
5	J-5,P1-17		
6	J-6,P1-12		
7	J-7,P1-7		
8	J-8,P2-2		
9	J-9,P2-3		
10	J-10,P2-8		
11	J-11,P1-10		
12	J-12,P1-1		
13	J-13,P2-9		
14	J-14,P2-10		
15	J-15,P1-5		
16	J-16,P1-13		
17	J-17,P2-1		
18	J-18,P1-14		

WIRE No.	HARNESS LOCATOR OPTIONAL ACC. 11BG CKTS.	CLR	AWG
28	CP-TB-4,11BG-TB-9		16
OPTIONAL ACC. 14AA & 14BA			
39	TS(AUX1)-30,TB-7		
40	TS(AUX1)-31,TB-8		
41	TS(AUX1)-32,TB-9		

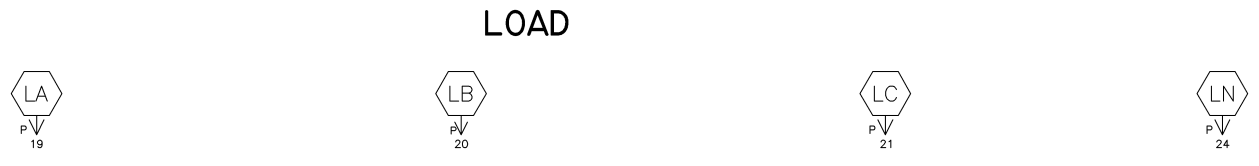
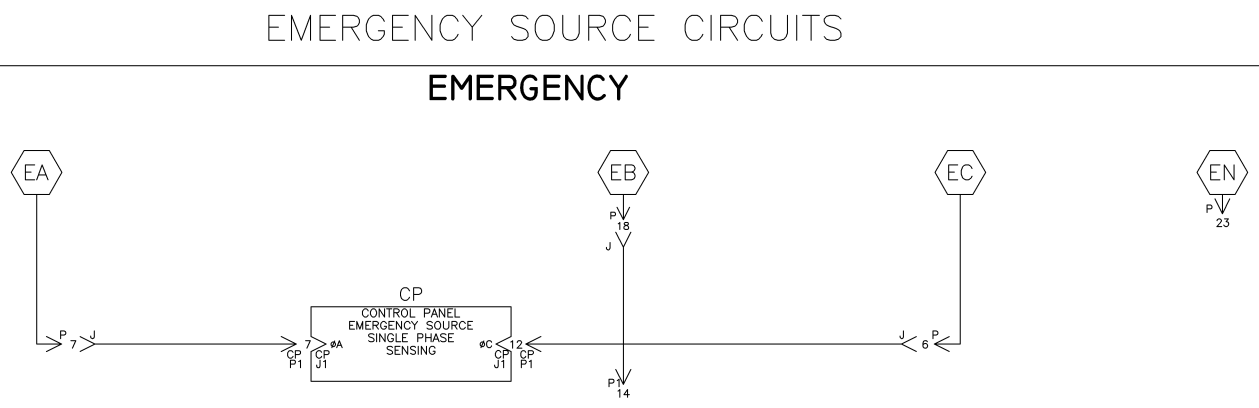
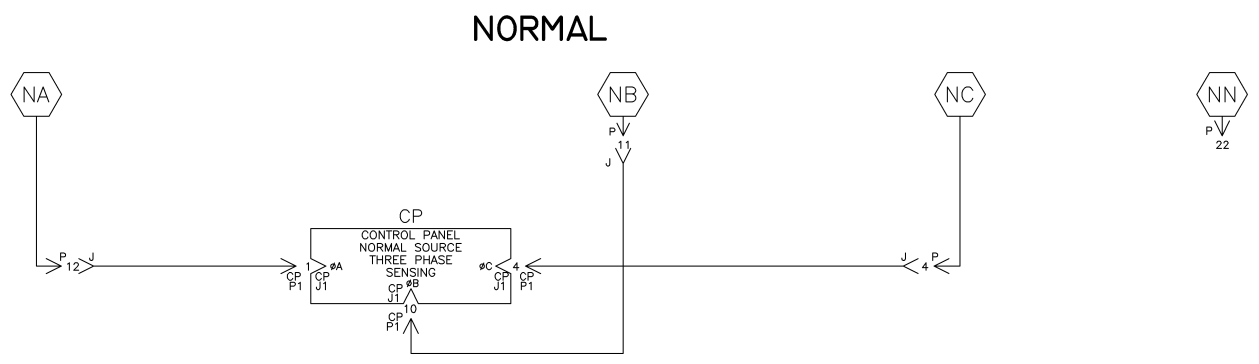
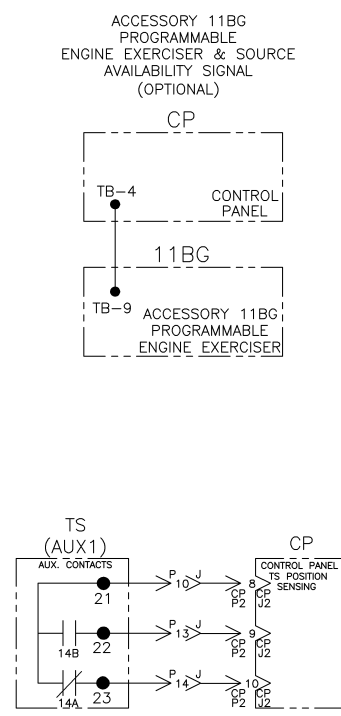

M	235174	TR	WK	1/3/11
L	234078	BK	BK	10/07/11
K	233030	AE	BK	07/25/11

PROJECT NAME:		REV. TO SHEET	ECN NO.	BY	APP.	DATE
WIRING DIAGRAM						
SERIES G300 ATS 3PH 1000-3200 AMPS						
"G" FRAME, GROUP 1 CONTROLS						
DRAWN BY	DATE	MANUFACTURING TOLERANCES TO BE IN ACCORDANCE WITH ASCO PROCEDURE MP-1-003. FOR PLASTIC PARTS SEE MP-1-005.		ASSEM. REF. NO.		COMPUTER GENERATED DRAWING
CHECKED	DATE	PROPERTY OF ASCO POWER TECHNOLOGIES. USE PERMITTED FOR OUR WORK ONLY. ALL RIGHTS OF DESIGN OR INVENTION ARE RESERVED.		SCALE	SIZE	DS
PROJECT APPROVAL	DATE	ASCO POWER TECHNOLOGIES, L.P.		DRAWING NO.		733503
FINAL APPROVAL	DATE	FLORHAM PARK, NEW JERSEY 07932 U.S.A.		ECN NO.	235174	SHEET 3 OF 4

