

GAS INLET FLANGE 3" 150 Lb
ANSI (ASA) B 16.5 - 1973

GAS VET POSITION
G. 1/2"
TO SEE SHEET 1/2

OIL CONNECTION INLET G. 3/4"

OIL CONNECTION OUTLET G. 3/4"

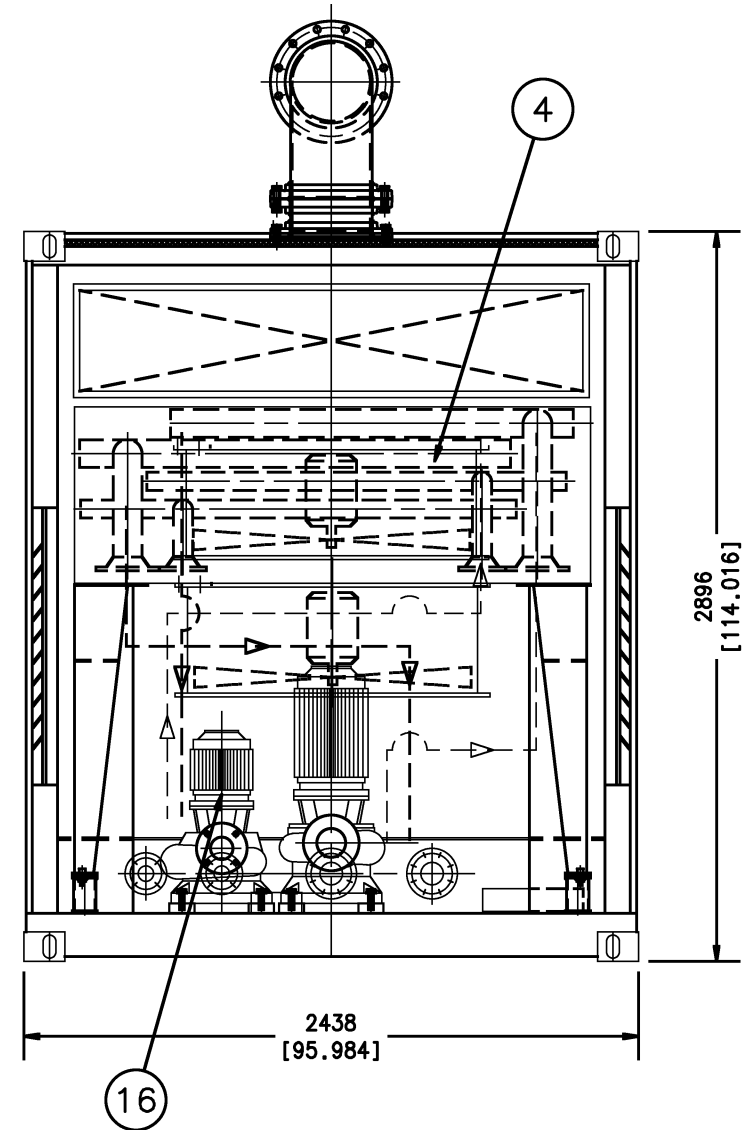
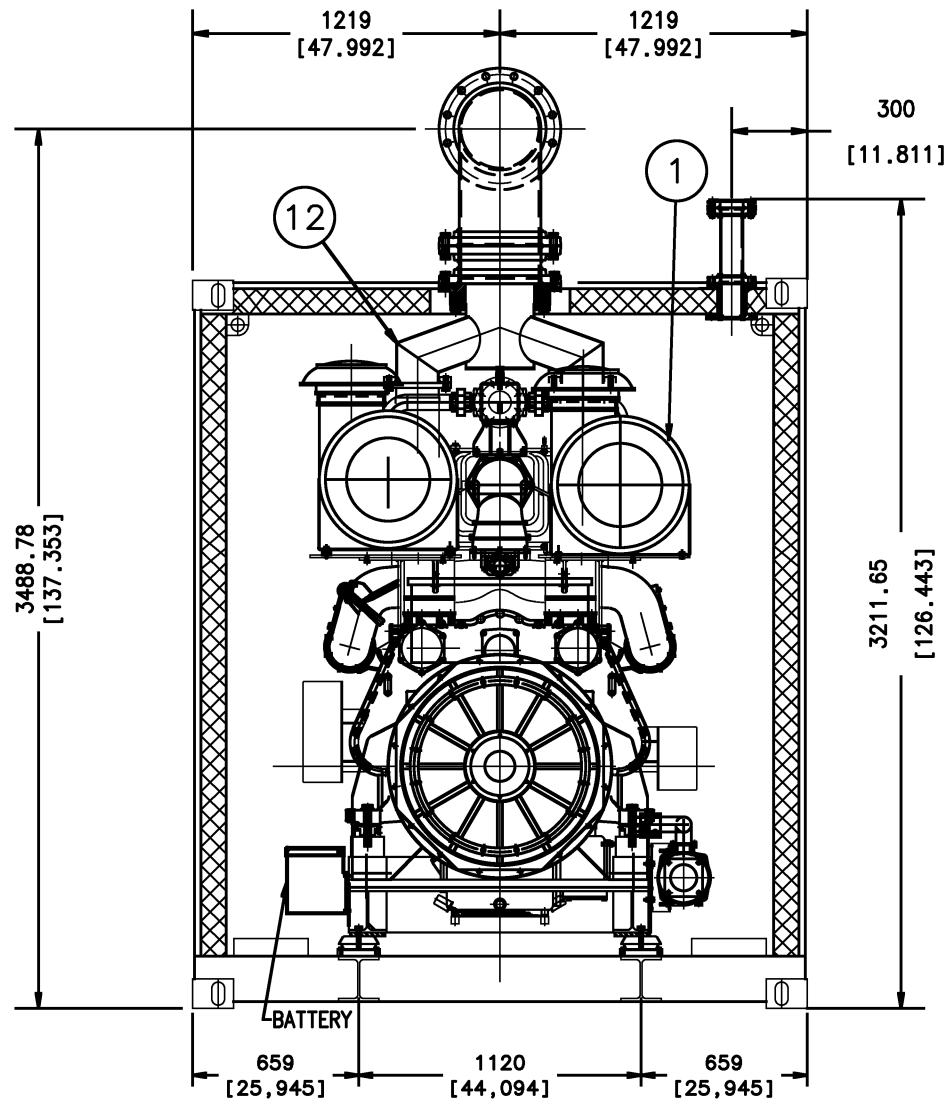
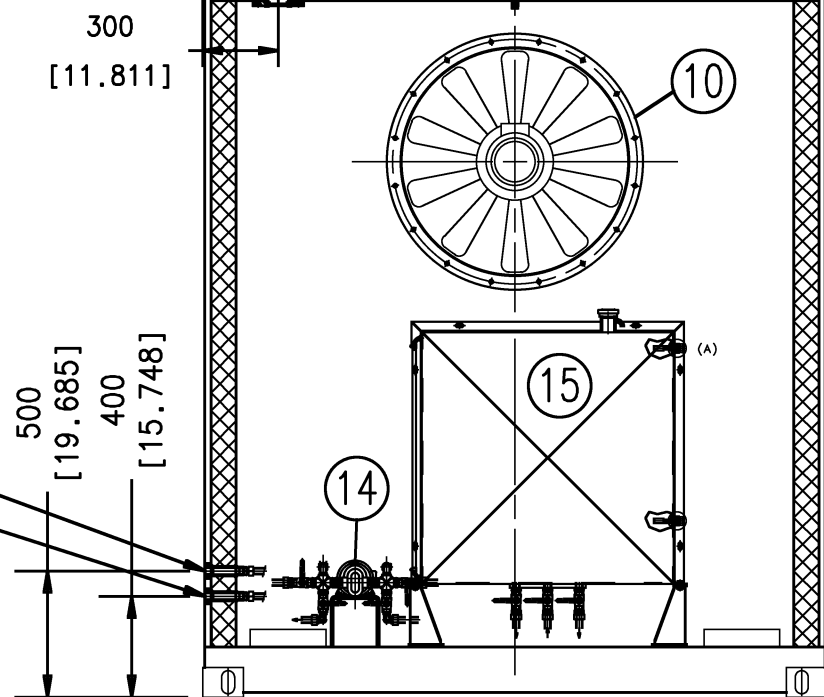

			JM.M.	AUT.
		F.Z.	REV.	
		F.M.	DIB.	
B	19-09-01	MODIFY GENERAL PLANE	J.M.M.	
A	22-03-01	ELIMINAR SENSOR DE NIVEL 76.00.818 Y ANADIR TAPON 74.86.104 EN EL DEPOSITO DE ACEITE.	F.Z.	
D		FECHA		
C		DESCRIPCION		
MODIFIC.				

CONTAINER ASSEMBLY (40 FEET)
ENGINE SFGLD 560/4/55
GENERAL LAYOUT



GUASCOR

ZUMAIA

Dibujado	10-01-00	F.Z.	CAD NO HACER CAMBIOS EN ESTE REPRODUCIBLE
Revisado	10-01-00	JM.E.	
Autoriz.	10-01-00	R.I.	
			Escala 1:30
REFERENCIA			MODIFICACIONES
2.3088.900			A B
SHEET 2/2			
Sustituye a:		Sustituido por:	
Este plano es propiedad de la empresa GUASCOR. Queda prohibida su reproducción así como su uso sin autorizacih.			