

500 Gallon UL 142 Tank

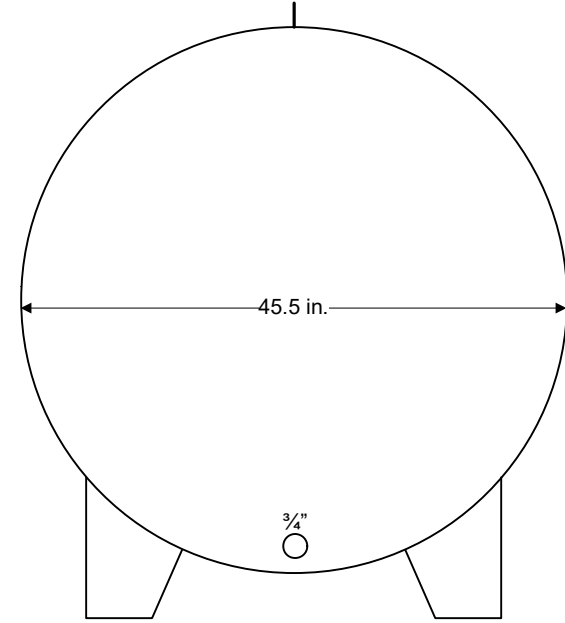
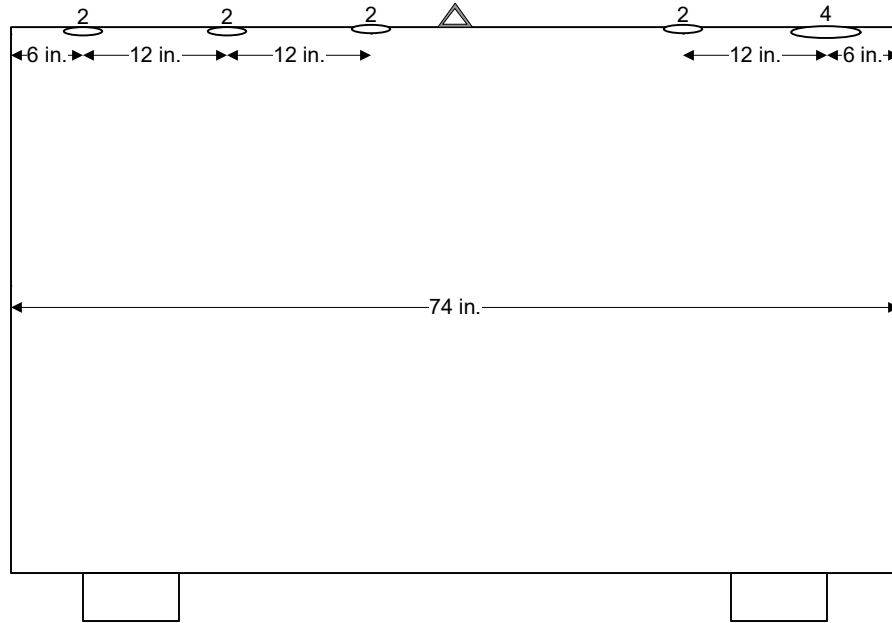

(1) 4" NPT Female Flange
 (4) 2" NPT Female Flanges
 UL142, File #MH48711

Exterior Gray Primer Finish
 Tank Factory Tested at 3 PSI
 1 Year Warranty on Material and Workmanship

*No Provision for Lost Product or Business

500 Gallon UL 142 Tank		PART #	
		NO.	DATE
DATE ORIGINAL 3/17/2011		DESCRIPTION A36 HR 12GA Steel	
SCALE 1/16:1			
LATEST REVISION	JOB NO.	WEIGHT	DRAWN S Guyer

KEESEEE
 TANK COMPANY INC.