



DCA400SSI4i

MQ POWER Whisperwatt™ Series

WhisperWatt™ 400

Prime Rating — 320 kW (400 kVA)

Standby Rating — 352 kW (440 kVA)

3-Phase, 60 Hertz, 0.8 PF

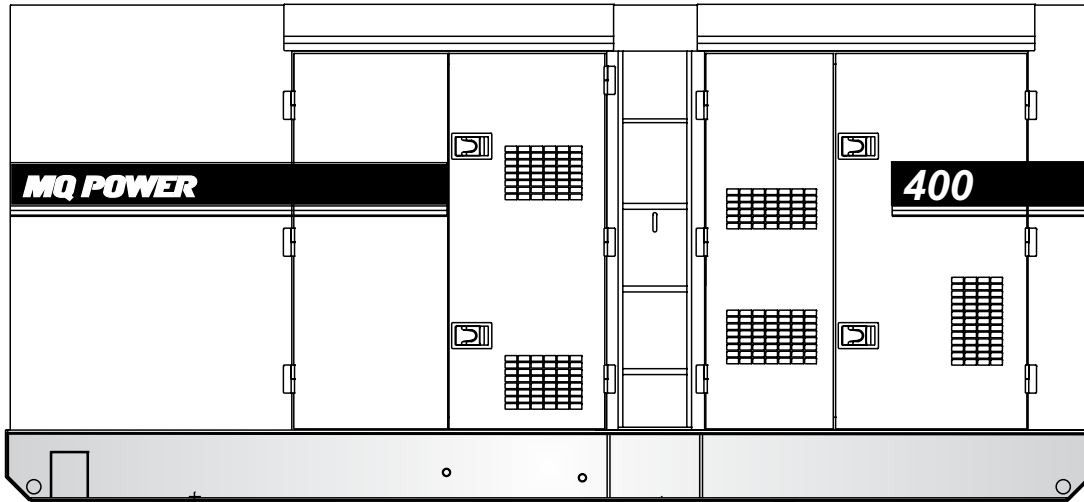

STANDARD FEATURES

- Heavy duty, 4-cycle, direct injection, charge air-cooled diesel engine provides maximum reliability.
- Brushless alternator reduces service and maintenance requirements and meets temperature rise standards for Class F insulation systems.
 - Open delta alternator design provides virtually unlimited excitation for maximum motor starting capability.
 - Automatic voltage regulator (AVR) provides precise regulation.
- Electronic governor system maintains frequency to $\pm 0.25\%$.
- Full load acceptance of standby nameplate rating in one step (NFPA 110, para 5-13.2.6).
- Sound attenuated, weather resistant, steel housing provides operation at 71 dB(A) at 23 feet. Fully lockable enclosure allows safe unattended operation.
- Internal fuel tank with direct reading fuel gauges are standard.
- E-coat primer with polyurethane enamel finish coat.
- Digital engine gauges including oil pressure, water temperature, battery volts, engine speed, and fuel level.
- Analog generator instrumentation including AC ammeter, AC voltmeter, frequency meter, ammeter phase selector switch, voltmeter phase selector switch, and voltage regulator adjustment potentiometer.
- ECU830 microprocessor-based digital generator controller.
 - Remote 2-wire start/stop control.
 - Operational temperature range of -40° to 85° C.
 - High visibility LCD display with heated screen and alphanumeric readout.
 - Modbus interface for gauge panel and expansion options.
 - DPF cleaning cycle indication.
- Automatic safety shutdown system monitors the water temperature, engine oil pressure, low coolant, overspeed, and overcrank. Warning lights indicate abnormal conditions.
- Complete power panel. Fully covered; three-phase terminals and single phase receptacles allow fast and convenient hookup for most applications including temporary power boxes, tools and lighting equipment. All are NEMA standard.
- Fuel/water separator. Removes condensation from fuel for extended engine life.
- Simultaneous single and three phase power.
- Voltage change-over board. Allows easy to change voltages as your applications require. 240/480 bus bar.
- Battery Switch.
- Emergency Stop Switch. When manually activated, shuts down generator in the event of an emergency.
- EPA emissions certified - Tier 4i emissions compliant.
 - Engine fitted with DOC and DPF.



DCA400SSI4i

MQ POWER Whisperwatt™ Series

SPECIFICATIONS

Generator Specifications	
Design	Revolving field, Self-ventilated Drip-proof, Single bearing
No. of Poles	4-pole
Excitation	Brushless with AVR
Standby Output	352 KW (440 kVA)
Prime Output	320 KW (400 kVA)
Generator RPM	1800
Voltage — 3Ø	208, 220, 240, 415, 440, 480V Reconnectable
Voltage — 1Ø	120, 127, 139, 240, 254, 277V Adjustable
Armature Connection	Star with neutral
Voltage Regulation (No load to full load)	±0.5%
Power Factor	0.8
Frequency	60 Hz
Frequency Regulation: No Load to Full Load	Isochronous under varying loads from no load to 100% rated load
Frequency Regulation: Steady State	±0.25% of mean value for constant loads from no load to full load.
Insulation	Class F
Sound Level dB(A) Full load at 23 feet	71

Engine Specifications	
Make / Model	Isuzu / 6WG1X
Emissions	EPA Interim Tier 4 Certified
Starting System	Electric
Design	4-cycle, water cooled, direct injection, turbocharged, charge air cooled
Displacement	15681 cc
No. cylinders	6
Bore x Stroke	147 x 154 mm
Gross Engine Power Output	532 hp (397 kWm)
BMEP	245 psi (1688 kPa)
Piston Speed	1707 ft/min (8.7 m/s)
Compression Ratio	16.5 : 1
Engine Speed	1800 rpm
Overspeed Limit	2070 rpm
Oil Capacity	15.1 gallons (57 liters)
Battery	12V 200Ah x 2 (24 V Systems)

Fuel System	
Recommended Fuel	ASTM-D975-No.1 & No.2-D*
Maximum Fuel Flow (per hour)	98.8 gallons (374 liters)
Maximum Inlet Restriction (Hg)	8.86 in (225 mm)
Fuel Tank Capacity	129 gallons (490 liters)
Fuel Consumption	gph lph
At full load	23.6 89.3
At 3/4 load	19.0 72.1
At 1/2 load	13.7 51.8
At 1/4 load	8.2 31.1

* - Use ultra-low sulfur diesel fuel.

Cooling System	
Fan Load	26.1 hp (19.5 kW)
Coolant Capacity (with radiator)	19.4 gallons (73.6 liters)
Coolant Flow Rate (per minute)	111 gallons (420 liters)
Heat Rejection to Coolant (per minute)	17440 Btu (18.4 MJ)
Maximum Coolant Friction Head	20.3 psi (140 kPa)
Maximum Coolant Static Head	29.5 feet (9.0 meters)
Ambient Temperature Rating	104°F (40°C)

Air	
Combustion Air	872 cfm (24.7 m³/min)
Maximum Air Cleaner Restriction	25 in. H ₂ O (6.2 kPa)
Alternator Cooling Air	2790 cfm (79.0 m³/min)
Radiator Cooling Air	14129 cfm (400 m³/min)

Exhaust System	
Gas Flow (full load)	1826 cfm (51.7 m³/min)
Gas Temperature	968°F (520°C)
Maximum Back Pressure	120.4 in. H ₂ O (30 kPa)

Amperage	
Rated Voltage	Maximum Amps
1Ø 120 Volt	888.9 Amps (4 wire)
1Ø 240 Volt	444.4 Amps (4 wire)
3Ø 240 Volt	962.3 Amps
3Ø 480 Volt	481.1 Amps
Main Line Circuit Breaker Rating	1000 Amps
Over Current Relay Trip Set Point	480 Amps

WARRANTY*

Isuzu Engine

12 months from date of purchase with unlimited hours or 24 months from date of purchase with 2000 hours (whichever comes first).

Generator

24 months from date of purchase or 2000 hours (whichever occurs first).

Trailer

12 months excluding normal wear items.

*Refer to the express written, one-year limited warranty sheet for additional information.

NOTICE

Generator is not intended for use in enclosed areas or where free flow of air is restricted.

Backfeed to a utility system can cause electrocution and/or property damage. Do not connect to any building's electrical system except through an approved device.

Specifications are subject to change without notice.



DCA400SSI4i

MQ POWER Whisperwatt™ Series

MQ POWER DECIBEL LEVELS

Our soundproof housing allows substantially lower operating noise levels than competitive designs. WhisperWatts are at home on construction sites, in residential neighborhoods, and at hospitals — just about anywhere.

- 90 — Subway / truck traffic
- 80 — Average city traffic
- 70 — **WhisperWatt at 23 feet**
— Inside car at 60 mph
- 60 — Air conditioner at 20 feet
- 50 — Normal conversation



GENERATOR OUTPUT PANELS

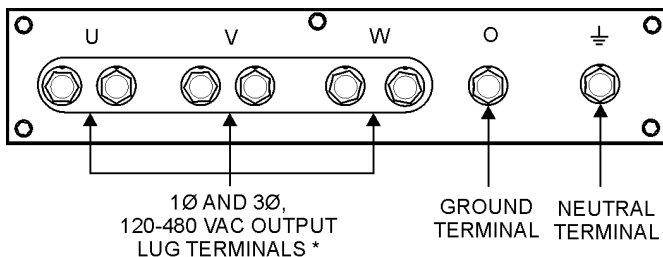
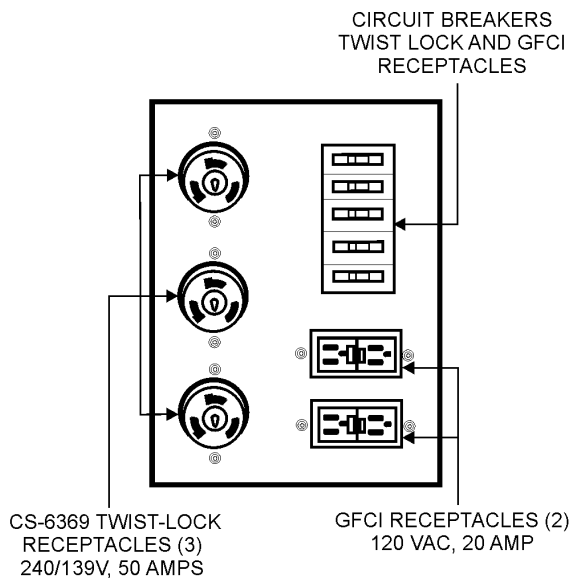

OPTIONAL GENERATOR FEATURES

- **Battery charger** — provides fully automatic and self-adjusting charging to the generator's battery system.
- **Jacket water heater** — for easy starting in cold weather climates.
- **Special batteries** — long life batteries provide extra engine cranking power.
- **Spring Isolators** — provides extra vibration protection for standby applications.
- **Trailer mounted package** — highway legal trailer with electronic or surge brakes with double or triple axle configuration. Extra capacity fuel tanks are also available.

OPTIONAL CONTROL FEATURES

- **Cam-Loks** — provides quick disconnect alternative to bolt-on connectors.
- **Pin and Sleeve Connectors** — provides industry standard connectors for all voltage requirements.
- **Output cable** — available in any custom length and size configuration.

OPTIONAL FUEL CELL FEATURES

- **Trailer Fuel Tank** — a second fuel cell located in the trailer allows for extended run time.
- **Subbase fuel cells (double wall)** — additional fuel cell for extended runtime operation. Contains a leak sensor, low fuel level switch, and a secondary containment tank. UL142 listed.
- 12 hours of minimum run time.
- 24 hours of minimum run time.



DCA400SSI4i

MQ POWER Whisperwatt™ Series

DIMENSIONS

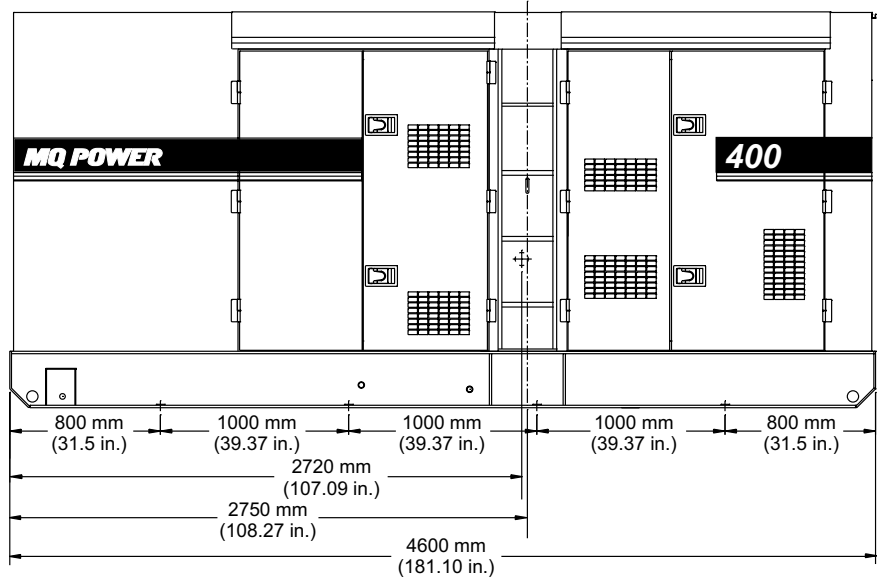
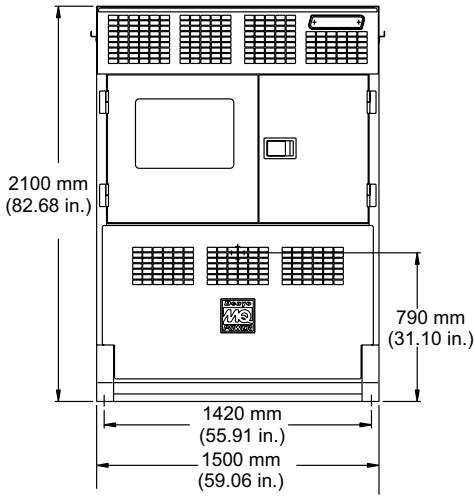

Weight	
Dry Weight	11,574 lbs. (5,250 kg)
Wet Weight	12,852 lbs. (5,830 kg)
Max. Lifting Point Capacity	16,500 lbs. (7,484 kg)

Generator can be placed on MQ Power Trailers
TRLR400XF and TRLR400XF3.

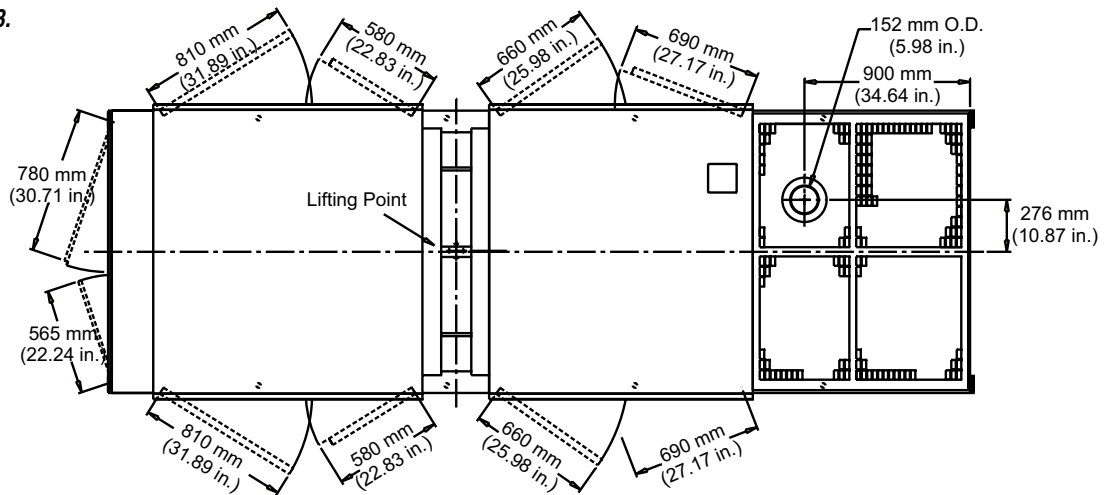

Manufactured by Denyo Co.

Your Multiquip dealer is:

