



DCA150USJ3CAN

MQ POWER Ultra-Silent Series

WhisperWatt™ 150

Prime Rating — 120 kW (150 kVA)

Standby Rating — 132 kW (165 kVA)

60 Hertz

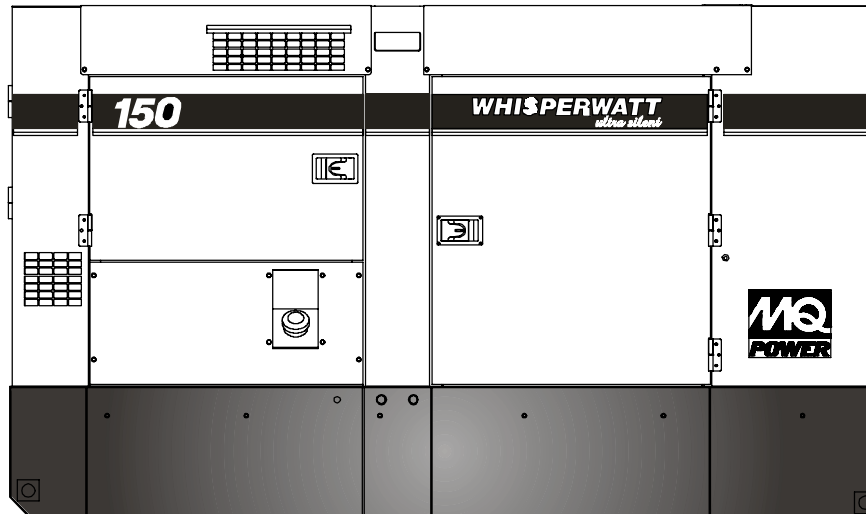

STANDARD FEATURES

- Heavy duty, 4-cycle, direct injection, diesel engine provides maximum reliability.
- Brushless alternator reduces service and maintenance requirements and meets temperature rise standards for Class F insulation systems.
- Open delta alternator design provides virtually unlimited excitation for maximum motor starting capability.
- Automatic voltage regulator (AVR) provides precise regulation.
- Electronic governor system maintains frequency to $\pm 0.25\%$.
- Full load acceptance of standby nameplate rating in one step (NFPA 110, para 5-13.2.6).
- Sound attenuated, weather resistant, steel housing provides operation at 63 dB(A) at 23 feet. Fully lockable enclosure allows safe unattended operation.
- UN31A compliant internal fuel tank with direct reading fuel gauges are standard.
- E-coat and powder coat paint provide durability and weather protection.
- External fuel fill.
- Complete engine analog instrumentation includes DC ammeter, oil pressure gauge, water temp. gauge, fuel level gauge, tachometer/hour meter, preheat indicator, and emergency shutdown monitors.
- Complete generator analog instrumentation includes voltage regulator control, ammeter phase selector switch, voltmeter phase selector switch, AC voltmeter, AC ammeter, frequency meter, panel light, and circuit breaker.
- Automatic safety shutdown system monitors the engine oil pressure and water temperature. Warning lights indicate abnormal conditions.
- Auto start/stop control allows generator to start automatically in the event of a commercial power failure when used in conjunction with a transfer switch.
- Complete power panel. Fully covered; three-phase terminals and single phase receptacles allow fast and convenient hookup for most applications including temporary power boxes, tools and lighting equipment. All are NEMA standard.
- Fuel/water separator removes condensation from fuel for extended engine life. Panel-mounted alarm light included.
- Tier 3 emissions compliant.
- Cold Weather Kit to maintain optimal temperature.
- Water Heater for easy starting in cold weather climates.
- CSA listed.



DCA150USJ3CAN

MQ POWER Ultra-Silent Series

SPECIFICATIONS

Generator Specifications	
Design	Revolving field, self-ventilated Drip-proof, single bearing
No. of Poles	4
Excitation	Brushless with AVR
Standby Output	132 kW (165 kVA)
Prime Output	120 kW (150 kVA)
Generator RPM	1800
Voltage — 3Ø	208, 220, 240, 415, 440, 480V Switchable
Voltage — 1Ø	120, 127, 139, 240, 254, 277V Switchable
Armature Connection	Star with Neutral / Zig Zag
Voltage Regulation (No load to full load)	±0.5%
Power Factor	0.8
Frequency	60 Hz
Insulation	Class F
Sound Level dB(A) Full load at 23 feet	63

Engine Specifications	
Make / Model	John Deere / 6068HF285
Emissions	Tier 3 Certified
Starting System	Electric
Design	4-cycle, water cooled, direct injection, turbocharged, air-to-air intercooled
Displacement	415.0 in ³ (6800 cc)
No. cylinders	6
Bore x Stroke (mm)	106 x 127
Gross Engine Power Output	197 hp (146 kW)
BMEP	229 psi (1,578 kPa)
Piston Speed	1500 ft./min. (8.62 m/s)
Compression Ratio	17.0:1
Engine Speed	1800 rpm
Overspeed Limit	2100 rpm
Oil Capacity	8.19 gallons (31 liters)
Battery	12V 128Ah x 1

Fuel System		
Recommended Fuel	ASTM-D975-No.1 & No.2-D	
Maximum Fuel Flow (per hour)	28.4 gallons (108 liters)	
Maximum Inlet Restriction (Hg)	5.9 in. (150 mm)	
Fuel Tank Capacity	214 gallons (810 liters)	
Fuel Consumption	gph	lph
At full load	8.6	32.6
At 3/4 load	6.9	26.3
At 1/2 load	5.2	19.5
At 1/4 load	2.9	11.1

Cooling System	
Fan Load	5.0 hp (3.7 kW)
Coolant Capacity (with radiator)	5.8 gallons (22.0 liters)
Coolant Flow Rate (per minute)	48 gallons (180 liters)
Heat Rejection to Coolant (per minute)	5324 Btu (5.62 MJ)
Heat Rejection to Room (per minute)	1821 Btu (1.92 MJ)
Maximum Coolant Friction Head	2 psi (13.8 kPa)
Maximum Coolant Static Head	21 feet (6.4 meters)
Ambient Temperature Rating	104°F (40°C)

Air	
Combustion Air	452 cfm (12.8 m ³ /min)
Maximum Air Cleaner Restriction	25 in. H ₂ O (6.25 kPa)
Alternator Cooling Air	1352 cfm (38.3 m ³ /min)
Radiator Cooling Air	2944 cfm (83 m ³ /min)

Exhaust System	
Gas Flow (full load)	1165 cfm (33 m ³ /min)
Gas Temperature	916°F (491°C)
Maximum Back Pressure	30 in. H ₂ O (7.5 kPa)

Amperage	
Rated Voltage	Maximum Amps
1Ø 120 Volt	333.3 Amps (4 wire)
1Ø 240 Volt	166.7 Amps (4 wire)
3Ø 240 Volt	361 Amps
3Ø 480 Volt	180 Amps
Main Line Circuit Breaker Rating	175 Amps
Over Current Relay Trip Set Point	84 Amps

WARRANTY*

John Deere Engine

12 months from date of purchase with unlimited hours or 24 months from date of purchase with 2000 hours (whichever comes first).

Generator

24 months from date of purchase or 2000 hours (whichever occurs first).

Trailer

12 months excluding normal wear items.

* Refer to the express written, one-year limited warranty sheet for additional information.

NOTICE

Generator is not intended for use in enclosed areas or where free flow of air is restricted.

Backfeed to a utility system can cause electrocution and/or property damage. Do not connect to any building's electrical system except through an approved device.

Specifications are subject to change without notice.



DCA150USJ3CAN

MQ POWER Ultra-Silent Series

MQ POWER DECIBEL LEVELS

Our soundproof housing allows substantially lower operating noise levels than competitive designs. Ultrasilents are at home on construction sites, in residential neighborhoods, and at hospitals — just about anywhere.

- 90 — Subway / truck traffic
- 80 — Average city traffic
- 70 — Inside car at 60 mph
- 60 — Air conditioner at 20 feet
- 50 — Normal conversation

Ultrasilent at 23 feet

63.0
DECIBELS

ULTRA-SILENT FEATURES

- **Low Noise Muffler** — Large capacity low noise muffler minimizes exhaust sound.
- **Soundproof Casing** — The new design divides the cabinet into three sections, separating the engine, muffler and radiator for more efficient cooling and reduces noise from the engine and fans.
- **New Cooling System** — An advanced design uses two separate air intake systems to cool the generator. The engine fan draws air in to cool the engine and generator housing while a second electric fan directly cools the radiator. With less air being drawn into the generator through each fan, considerably less noise is produced through the top of the generator.
- **Environmental Design** — Constructed using an integrated environmental skid and fuel tank. This design fully contains fuel leakage and any liquid that might leak from the engine such as lube oil or radiator coolant. All potentially hazardous liquids are contained without contaminating the surrounding area.

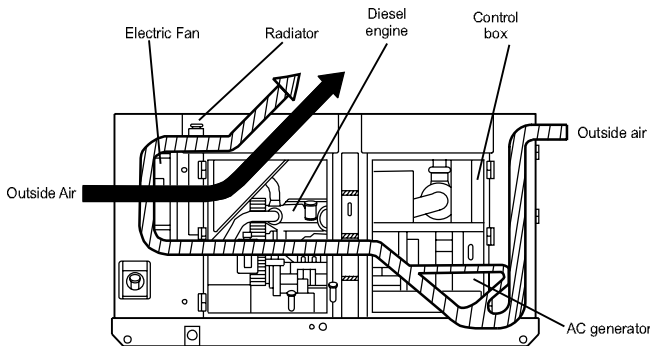

Flow of Cooling Air

GENERATOR OUTPUT PANEL

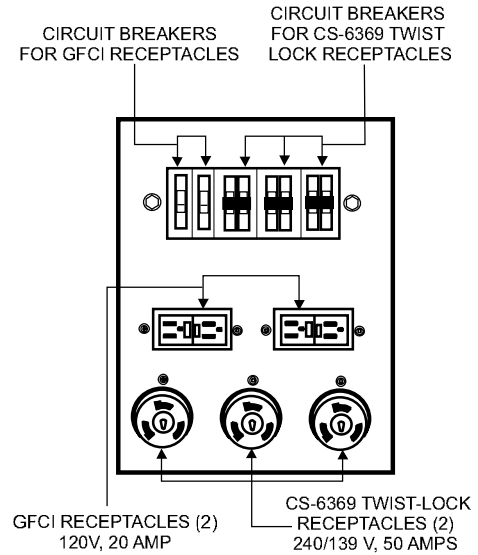

OPTIONAL CONTROL FEATURES

- **Emergency stop switch**
- **Audible alarm** alerts operator of abnormal conditions.

OPTIONAL GENERATOR FEATURES

- **Battery charger** — provides fully automatic and self-adjusting charging to the generator's battery system.
- **Special batteries** — long life batteries provide extra engine cranking power.
- **Spring isolators** — provides extra vibration protection for standby applications.
- **Low coolant level shutdown** — provides protection from critically low coolant levels. Includes control panel warning light.

- **Trailer mounted package** — highway legal, double axle trailer with electronic or surge brakes.

OPTIONAL OUTPUT CONNECTIONS

- **Cam-Lok Connectors** — provides quick disconnect alternative to bolt-on connectors.
- **Pin and Sleeve Connectors** — provides industry standard connectors for all voltage requirements.
- **AC Output Cable** — available in any custom length and size configuration.



DCA150USJ3CAN

MQ POWER Ultra-Silent Series

DIMENSIONS

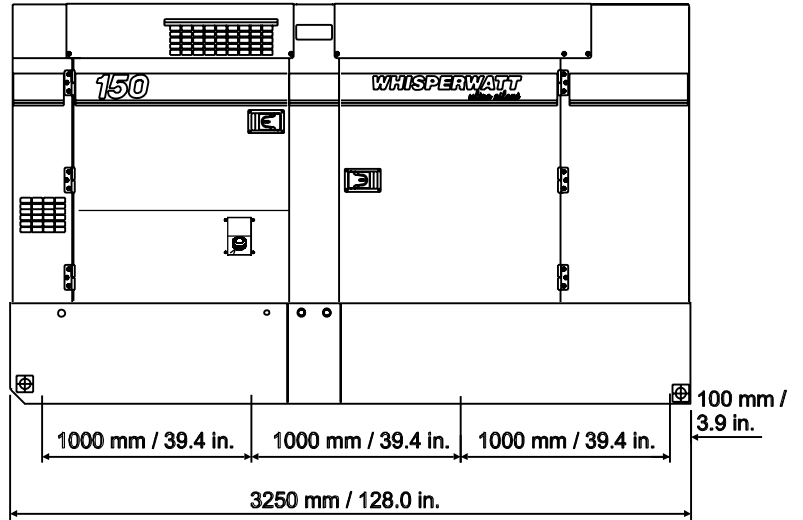
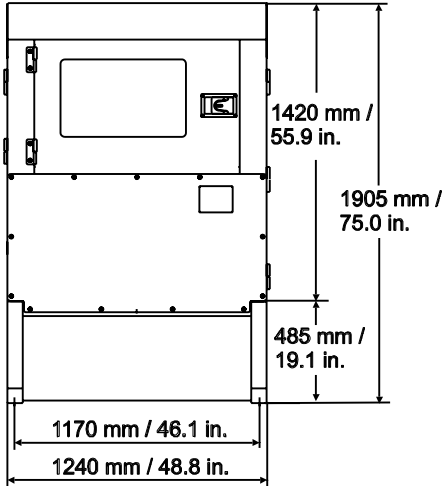

Weight	
Dry Weight	7,099 lbs. (3,220 kg)
Wet Weight	8,719 lbs. (3,955 kg)
Max. Lifting Point Capacity	14,050 lbs. (6,370 kg)

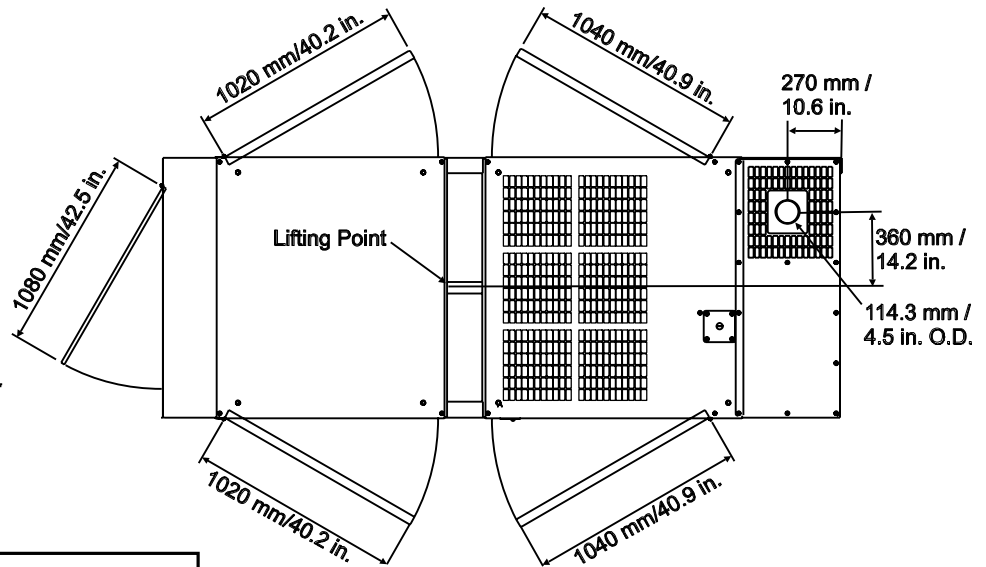

Generator can be placed on an MQ Power Model TRLR150US Tandem Axle Trailer.

Manufactured by Denyo Co.

Your MultiQuip dealer is:





TRLR180XF

MQ POWER Tandem Axle Trailer

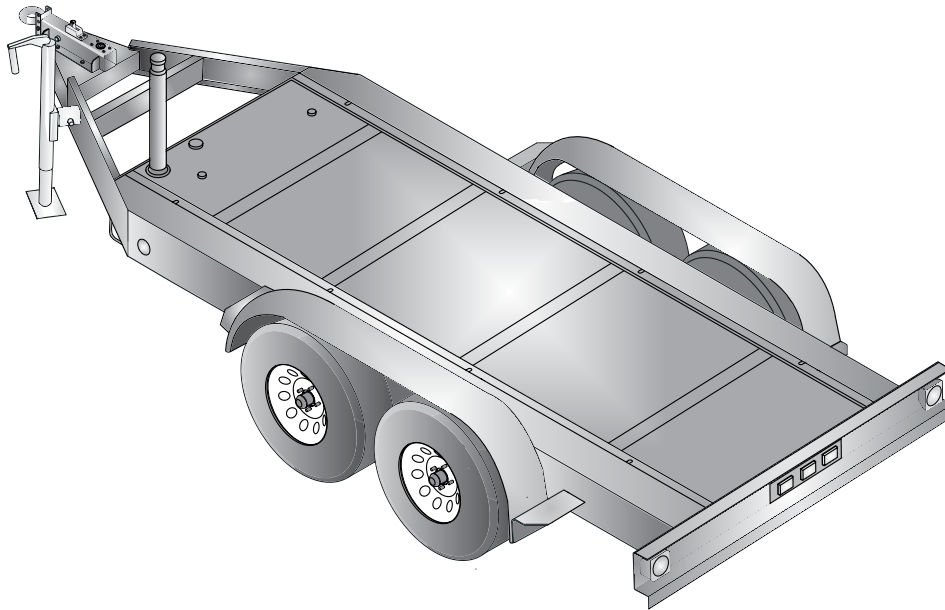

TRLR180XF Technical Data

Gross Vehicle Weight Rating (GVWR) — 12,000 lbs (5,443 kg)	Tire Size — ST235/80R16 LR-E
Gross Axle Weight Rating (GAWR) — 7,000 lbs (3,175 kg) (ea.)	Wheel Bolt Pattern — 8 Lug on 6.5 in
Actuator Rating — 12,500 lbs (5,670 kg)	Tire Load Rating — 3,500 lbs/1,588 kg (ea.)
Coupler Rating — See coupler options on back page	Dimensions (LxWxH) — See back page

STANDARD TRAILER EQUIPMENT

- Fits MQ Power Generator Model DCA150SSJU4F
- Tandem-axle Design with Leaf Spring Suspension
- H.D. Welded Steel Frame Construction
- Structural Channel for Generator Mounting and Support
- Integral Fuel Cell; Single-wall Steel Design, 210-Gallon Capacity; UN31A Certified
- Replaceable, Bolt-on Hydraulic Brake Actuator
- Surge Hydraulic-actuated Drum Brakes (all axles)
- Hydraulic Uni-servo Drum Brakes with Free-backing Plates-12-inch Cluster
- D.O.T. Steel Brake Lines, Brass Tees and Rubber Hydraulic Brake Hoses
- 4-hole Channel Allows 3-position, Adjustable Coupler Height; 4-inches O/A
- Tongue Mounted Swivel Jack with Flat Disc-foot (rated 5,000 pound lift)
- Replaceable Bolt-on Steel Fenders
- High-gloss Enamel Coated Frame, Channel, Actuator and Fenders
- D.O.T. Approved Tail Lamps, Stop Lamps, Turn Signal Lamps, Side Marker Lamps
- Weatherproof, Rubber Armored, 3-piece Trailer Light Wiring Harness



TRLR180XF

MQ POWER Tandem Axle Trailer

OPTIONAL TRAILER EQUIPMENT

- Bolt-on Electric Brake Coupler Plate with Electric-actuated Drum brakes (all axles)
- Electric Breakaway Safety Device (electric-actuated brakes)
- Adjustable 2 5/16-inch Ball Coupler
- Adjustable 3-inch Pintle-eye Coupler
- Rear Stabilizer Stands
- Tongue-Mounted Utility Storage Box
- Anti-Theft Wheel Lock
- Spare Tire with Locking Mount

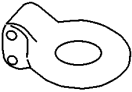
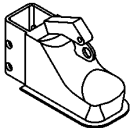
Coupler Options	
3" PINTLE EYE 20,000 lbs	
#EE36264	
2-5/16" BALL COUPLER 14,000 lbs	
#EE43253	

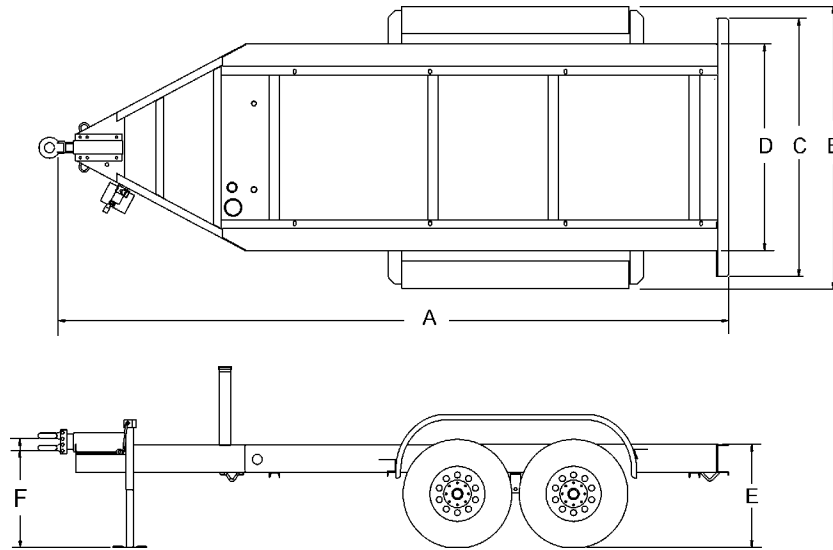

Trailer Weight	
Without fuel	With fuel
2,580 lbs. (1,170 kg)*	4,119 lbs. (1,870 kg)*

* Weight is approximate

Trailer Dimensions						
A	B	C	D	E	F	
					Min	Max
204 in.	86.5 in.	75 in.	62 in.	25.2 in.	22.3 in.	26.3 in.

Your Multiquip dealer is:

