

Shown with  
Optional Equipment

## FEATURES



### EMISSIONS

- Meets most worldwide emissions requirements down to 0.5 g/bhp-hr NO<sub>x</sub> level without after treatment

### FULL RANGE OF ATTACHMENTS

- Wide range of bolt-on system expansion attachments, factory designed and tested

### SINGLE-SOURCE SUPPLIER

- **Fully Prototype Tested** with certified torsional vibration analysis available

### WORLDWIDE PRODUCT SUPPORT

- With over 1,800 dealer branch stores operating in 166 countries, you're never far from the Caterpillar part you need.
- 99.5% of parts orders filled within 48 hours. The best product support record in the industry.
- Caterpillar dealer service technicians are trained to service every aspect of your electric power generation system.
- Customer Support Agreements offer back-to-back services from scheduled inspections and preventive maintenance to before-failure overhauls and Total Cost-Per-Hour Guarantees.

## CONTINUOUS 2055 ekW

60 Hz

Caterpillar is leading the power generation marketplace with Power Solutions engineered to deliver unmatched flexibility, expandability, reliability, and cost-effectiveness.



### CAT® G3520C GAS ENGINE

- Robust high speed diesel block design provides prolonged life and lower owning and operating costs
- Designed for maximum performance on low pressure pipeline natural gas
- Simple open chamber combustion system for reliability and fuel flexibility
- Leading edge technology in ignition system and air/fuel ratio control for lower emission and engine efficiency
- One electronic control module handles all engine functions: ignition, governing, air fuel ratio control, and engine protection



### CAT SR4B GENERATOR

- Designed to match performance and output characteristics of Caterpillar engines
- 2/3 pitch stator winding for minimum harmonic distortion and maximum voltage flexibility
- Segregated low voltage (AC/DC) accessory box provides single point access to accessory connections



### CAT CONTROL MODULE

- Designed to meet individual customer needs:
  - Gas Engine Control Module provides full-featured, engine management and control functions, purge cycle, staged shutdown logic, plus programmable protective relaying functions
- Remote control and monitor capability options

**FACTORY INSTALLED STANDARD & OPTIONAL EQUIPMENT**

System	Standard	Optional
<b>Air Inlet</b>	2 element, single stage air cleaner with enclosure, service indicator, horizontal mount (shipped loose)	2 elements with enclosure vertical mount (shipped loose). Stand to mount horizontal or option vertical air cleaner. Heavy duty air cleaner w/precleaner, horizontal mount (shipped loose)
<b>Cooling</b>	Engine driven water pumps for jacket water and aftercooler circuit, jacket water and SCAC thermostats ANSI/DN customer flange connections for JW inlet and outlet (ANSI 6 in./DN 150), SCAC system has Cat flanges	Remote horizontal radiator for JW and SCAC circuits, water level switches included but not wired, 400/480V electric driven fans with guard, motor control and disconnect switch included.
<b>Engine Control Module</b>	Fuel/air ratio control Start/stop logic: gas purge cycle, stage shutdown Engine Protection Systems: detonation sensitive timing, high jacket water temperature, low oil pressure, failure to start overcrank, overspeed, high oil temperature, emergency stop, transient richening and turbo bypass control	
<b>Exhaust</b>	Dry exhaust manifolds, insulated and shielded, center section cooled turbochargers Cat flanged outlet on turbochargers Individual exhaust port and turbocharger outlet wired to integrated Temperature Sensing Module with Gas ECM providing alarms and shutdowns	15 dBA muffler, 18 dBA muffler, 25 dBA muffler with ANSI style flanges. Spark arresting muffler with ANSI style flanges. Weld flanges, elbows, expanders, and flexible fittings
<b>Fuel</b>	Electronic air fuel ratio control (Engine Control Module: ADEM III based, electronic fuel control valve, throttle plate; 24V DC actuator, electronically controlled by ECM: gas shutoff valve, 24 volt energized-to-run: fuel system sized for low pressure pipeline natural gas fuel supply (35-350 mbar) with 31.5 to 47.2 MJ/N·m <sup>3</sup> (800 to 1200 Btu/cu ft) energy content.	Fuel filter (non-coalescent) Gas pressure regulator ETR (Energized-to-Run), 24 volt gas shutoff valve
<b>Ignition</b>	Electronic ignition system, individual cylinder timing and detonation control, sensors (1 per 2 cylinders) to monitor detonation	
<b>Integrated Thermo Sensing Module (ITSM)</b>	24 thermocouples to input individual exhaust port temperatures and turbo inlet and outlet temperatures on both the turbine and compressor	CCM: transfers Cat DataLink information through RS232 to customer terminal
<b>Generator</b>	Permanent magnet excitation, 105° C rise, two bearing, six lead, 3-phase sensing, platinum stator RTDs, Class H insulation, Digital Voltage Regulator with adjustable 1:1 or 2:1 volt/Hz, bus bar termination, extension box, segregated low voltage wiring panel, winding temperature detectors, anti-condensation space heaters	Digital Voltage Regulator with KVAR/PF control, reverse power protection and remote monitoring connection. Oversize and premium generators, medium and high voltage generators, bearing temperature detectors Low voltage cable extension box
<b>Governor</b>	Electronic (ADEM III)	Electronic load sharing
<b>Control Panels</b>	EMCP II+	Local alarm and remote annunciator modules Synchronizing module
<b>Lube</b>	Lubricating oil and filter, oil drain valve, crankcase breathers, gear type lube oil pump, integral lube oil cooler, filler/dipstick	Closed Crankcase ventilation system, prelube pump
<b>Mounting</b>	330 mm structural steel rails (for low and medium voltage units), high voltage units have engine mounted to rails and rails to base with generator mounted to base spring-type anti-vibration mounts (shipped loose)	
<b>Starting/Charging</b>	45 amp charging alternator, dual 50 MT 24 volt starting motors, batteries with rack and cables, batteries disconnect switch	Battery charger, air starting system, jacket water coolant heaters, 9 kW (480V/3 phases with 240V/1 phase pump, includes isolation valves) oversize batteries
<b>General</b>	Damper guard	Manual barring device, certifications, crankcase explosion relief valves.

**SPECIFICATIONS**

**CAT SR4B GENERATOR**

Frame size	827
Excitation	Permanent magnet
Pitch	0.667
Number of poles	4
Number of bearings	2
Number of leads	6
Insulation	UL 1446 Recognized Class H Insulation
IP rating	Drip proof IP22
Alignment	Pilot shaft
Overspeed capability	125%
Wave form	Less than 5% deviation
Paralleling kit droop transformer	Standard
Voltage regulator	3-phase sensing with adjustable 1:1 or 2:1 Volts/Hz, UL 508A Listed
TIF	Less than 50
THD	Less than 3%

Consult your Caterpillar dealer for available voltages.

**CAT ENGINE**

G3520C SCAC, 4-stroke-cycle watercooled Gas	
Bore — mm (in)	170 (6.7)
Stroke — mm (in)	190 (7.5)
Displacement — L (cu in)	86 (5270)
Compression ratio	11.3:1
Aspiration	Separate Circuit Aftercooled
Fuel system	Electronic Ignition System
Governor type	Electronic (ADEM III)

**CAT CONTROL PANEL**

<b>24 Volt DC Control</b>
NEMA 1, IP22 enclosure
Electrically dead front
Lockable hinged door
Generator instruments meet ANSI C-39-1
Terminal box mounted
Single location customer connector point
EC compliant — segregated AC/DC connections and wiring

**TECHNICAL DATA**

Generator Set — 1800 rpm/60 Hz/480 Volts		DM3195-00		DM3194-00	
<b>G3520C LE Gas Generator Set</b> Emission level (NOx) Aftercooler, two stage (JW in/SCAC)	g/bhp-hr Deg C      Deg F	0.5 54      130		1.0 54      130	
<b>Package Performance (1)</b> Power rating @ 1.0 pf (unity) Power rating @ 0.8 pf kVA rating @ 0.8 pf	ekW ekW kVA	2070 2055 2569		2070 2055 2569	
<b>Fuel Consumption (2)</b> Electrical Efficiency @ 1.0 pf 100% load with fan 75% load with fan 50% load with fan	% N·m³/hr      scf/hr N·m³/hr      scf/hr N·m³/hr      scf/hr	37.3 557      20,810 435      16,233 305      11,387		38.2 544      20,292 424      15,823 297      11,097	
<b>Altitude Capability (3)</b> At 77° F ambient	M      ft	975      3200		975      3200	
<b>Cooling System</b> Jacket water temperature (maximum outlet)	Deg C      Deg F	90      194		90      194	
<b>Exhaust System</b> Combustion air inlet flow rate Exhaust stack gas temperature Exhaust gas flow rate Exhaust flange size — (internal diameter) System backpressure (maximum allowable)	N·m³/min      scfm Deg C      Deg F N·m³/min      cfm mm      in kPa	172      6410 478      893 491      17,348 360      14 5		163      6097 487      909 473      16,714 360      14 5	
<b>Heat Rejection (4)</b> Low Heat Value (LHV) fuel input (1) Heat rejection jacket water (includes JW, oil cooler and A/C — stage 1). Heat rejection to A/C — stage 2 Heat rejection to exhaust (LHV to 350° F) Heat rejection to atmosphere from engine Heat rejection to atmosphere from generator	kW      Btu/min kW      Btu/min kW      Btu/min kW      Btu/min kW      Btu/min	5743      326,664 1239      70,479 161      9150 1251      71,169 154      8763 69      3924		5599      318,495 1186      67,467 144      8167 1230      69,984 154      8763 69      3924	
<b>Alternator</b> Motor starting capability @ 30% voltage dip* Frame Temperature rise	skVA Deg C	5226 827 105		5226 827 105	
<b>Lube System</b> Lube oil refill volume w/filter change for std sump	L      Gal	541      143		541      143	
<b>Emissions**</b> NOx @ 5% O <sub>2</sub> CO @ 5% O <sub>2</sub> HC (total) @ 5% O <sub>2</sub> HC (non-methane) @ 5% O <sub>2</sub> Exhaust O <sub>2</sub> (dry)	g/bhp-hr g/bhp-hr g/bhp-hr g/bhp-hr %	0.5 2.1 4.8 0.73 9.9		1.0 2.4 4.0 0.61 9.4	

\*Assume synchronous driver.

\*\*Emissions data measurements are consistent with those described in EPA CFR 40 Part 89 Subpart D & E and ISO8178-1 for measuring HC, CO, PM, NOx. Data shown is based on steady state engine operating conditions of 25° C (77° F), 96.28 kPa (28.43 in Hg) and fuel having an LHV of 35.6 MJ/N·m³ (905 Btu/cu ft) at 101.60 kPa (30.00 in Hg) absolute and 0° C (32° F). Not to exceed emission data shown is subject to instrumentation, measurement, facility, and engine fuel system adjustments.

**RATING DEFINITIONS AND CONDITIONS**

**Continuous** — Output available without varying load for an unlimited time.

**(1) Ratings** are based on pipeline natural gas having an LHV of 35.6 MJ/N·m³ (905 Btu/cu ft) and 80 MN. For values in excess of the altitude, temperature, inlet/exhaust restriction, or for natural gas compositions different from the conditions listed, contact your local Caterpillar dealer.

**(2) Ratings and fuel consumption** are based on ISO3046/1 standard reference conditions of 25° C (77° F) and 100 kPa (29.61 in Hg) with 0,+5% fuel tolerance.

**(3) Altitude** capability is based on 2.5 kPa inlet and 5.0 kPa exhaust restriction.

**(4) Heat Rejection** — values based on ISO3046/1 with fuel tolerance of ±3% and 2.5 kPa inlet and 5.0 kPa exhaust restriction. All performance values listed on this page are listed at these conditions except fuel consumption (2).

**C O N T I N U O U S**  
**P O W E R      2 0 5 5   e k W**  
**6 0   H z**



**OPEN GENERATOR SET PACKAGE — SIDE VIEW**

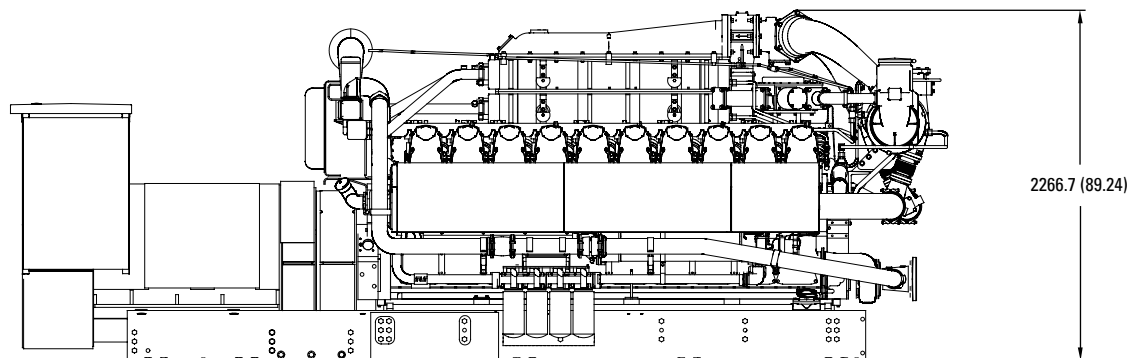

**OPEN GENERATOR SET PACKAGE — TOP VIEW**

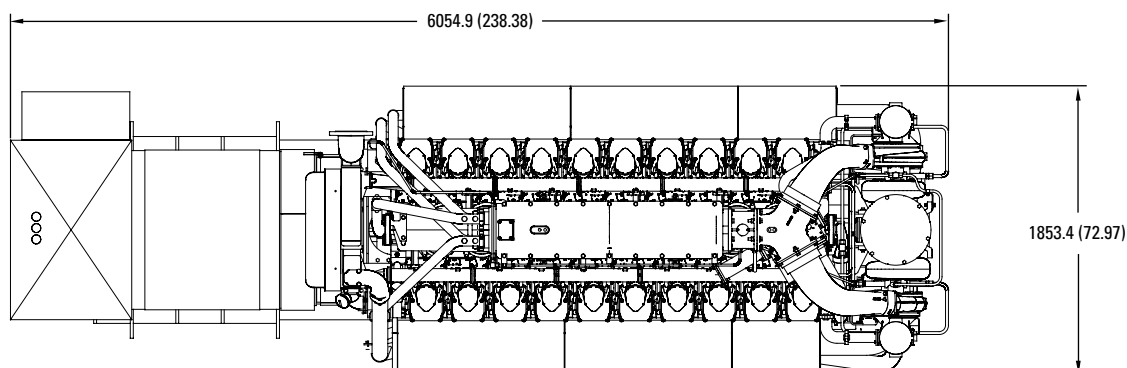

Package Dimensions		
<b>Length</b>	6054.9 mm	238.38 in
<b>Width</b>	1853.4 mm	72.97 in
<b>Height</b>	2266.7 mm	89.24 in
<b>Shipping Weight</b>	18 350 kg	40,437 lb

Note: Do not use for installation design.  
 See general dimension drawings  
 for detail (Drawing # 234-1955).

www.CAT-ElectricPower.com

TMI Reference No.: DM3195-00, DM3194-00

U.S. sourced

LEHE2832 (1-03)

© 2003 Caterpillar  
 All rights reserved.  
 Printed in U.S.A.

Materials and specifications are subject to change without notice.  
 The International System of Units (SI) is used in this publication.